

Rack-mounted DCS Signal Conditioners 18-RACK

CURRENT LOOP SUPPLY

(linearizing; field-programmable)

Functions & Features

- Powering a 4 – 20 mA DC current loop
- Microprocessor based
- Shortcircuit protection
- Applicable to smart transmitters
- Field-programmable linearization data
- Loop testing via hand-held programmer PU-2x
- Usable as Linearizer for 4 – 20 mA DC signals
- Second channel output available at the front terminals and at the Standard Rack connector

Typical Applications

- Various 2-wire transmitters
- Providing isolation and linearization for a 2-wire temperature transmitter
- Linearizing weir flowmeter output to provide a linear-to-volume signal

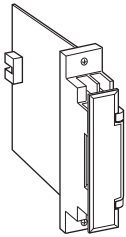

MODEL: 18JDL-A[1]66-R

ORDERING INFORMATION

- Code number: 18JDL-A[1]66-R

Specify a code from below for [1].

(e.g. 18JDL-A366-R)

Default setting (table next) will be used if not otherwise specified.

No linearization data will be programmed if you don't specify type of linearization and required data.

- Linearization data

Code 1 segment data: Use Ordering Information Sheet (No. ESU-1669) to specify linearization data.

Code 3 T/C, Code 4 RTD: Specify input sensor type and temperature range.

LINEARIZATION CODE	DEFAULT
1: Segment data	Linear
2: Square root extraction	—
3: Thermocouple	K 0 – 1000°C
4: RTD	Pt 100 0 – 100°C

INPUT

Current

A: 4 – 20 mA DC (Input resistance 250 Ω)

[1] LINEARIZATION

0: None

1: Segment data

2: Square root extraction

3: Thermocouple

4: RTD

OUTPUT 1

Voltage

6: 1 – 5 V DC (Load resistance 2000 Ω min.)

OUTPUT 2

Voltage

6: 1 – 5 V DC (Load resistance 2000 Ω min.)

POWER INPUT

DC Power

R: 24 V DC

(Operational voltage range 24 V ±10 %, ripple 10 %p-p max.)

RELATED PRODUCTS

- Programming Unit (model: PU-2x)
- PC configurator software (model: JXCON)

Downloadable at our web site.

A dedicated cable is required to connect the module to the PC. Please refer to the internet software download site or the users manual for the PC configurator for applicable cable types.

GENERAL SPECIFICATIONS

Construction: Rack-mounted; terminal access via screw terminals on the front and connector on the rear; terminal cover provided

Connection

Input: M3.5 screw terminals (torque 0.8 N·m)

Output 1: Connector

Output 2: M3.5 screw terminals (torque 0.8 N·m)

and connector

Power input: Supplied from connector

Screw terminal: Nickel-plated steel

Isolation: Input to output 1 to output 2 to power

Overrange output: Approx. -10 to +120 % at 1 - 5 V

Linearization: 16 points max. represented as percentage of full-scale

Adjustments: Programming Unit (model: PU-2x); linearization data, zero and span, simulating output, etc. (Refer to the users manual of JXCON for the adjustments configurable with JXCON.)

SUPPLY OUTPUT

Output voltage: 24 - 28 V DC with no load

Current rating: ≤ 22 mA DC

• **Shortcircuit Protection**

Current limited: 30 mA max.

Protected time duration: No limit

INPUT SPECIFICATIONS

■ **DC Current:** Input resistor incorporated

OUTPUT SPECIFICATIONS

The output goes below 0 % when the input is open.

LINEARIZATION

• **No linearization:** The output is proportional to the input.

• **Segment data:** 16 points (15 segments) max. within the range of -15.00 to +115.00 % input or output represented as percentage of fullscale

• **Square root extraction**

Low-end cutout: 5 % (output); curve characteristics as in the figure below

■ Square root extraction

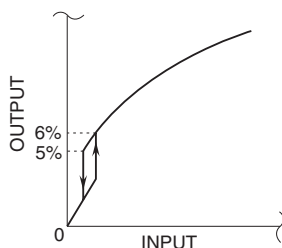

• Thermocouple linearizable range

T/C	USABLE RANGE	
	°C	°F
(PR)	0 to 1760	32 to 3200
K (CA)	-270 to +1370	-454 to +2498
E (CRC)	-270 to +1000	-454 to +1832
J (IC)	-210 to +1200	-346 to +2192
T (CC)	-270 to +400	-454 to +752
B (RH)	0 to 1820	32 to 3308
R	-50 to +1760	-58 to +3200
S	-50 to +1760	-58 to +3200

Note: For the temperatures that range below 0°C, the transmitter may partially not satisfy the described accuracy. Consult factory.

• RTD linearizable range

RTD	USABLE RANGE	
	°C	°F
JPt 100 (JIS '89)	-200 to +500	-328 to +932
Pt 100 (JIS '89)	-200 to +650	-328 to +1202
Pt 100 (JIS '97, IEC)	-200 to +650	-328 to +1202
Pt 50Ω (JIS '81)	-200 to +500	-328 to +932
Ni 508.4 Ω	-50 to +200	-58 to +392

Note: Pt 100 (JIS '89) is deviated from Pt 100 (JIS '97) only within the described accuracy.

INSTALLATION

Current consumption: Approx. 85 mA

Operating temperature: -5 to +55°C (23 to 131°F)

Operating humidity: 30 to 90 %RH (non-condensing)

Mounting: Standard Rack 18BXX or 18KBXX

Weight: 150 g (0.33 lb)

PERFORMANCE in percentage of span

Accuracy: ±0.1 % with segment gain ≤ 1 [±0.1 % × gain] with segment gain > 1

Temp. coefficient: ±0.015 %/°C (±0.008 %/°F)

Response time: ≤ 0.5 sec. (0 - 90 %)

Line voltage effect

Output signal: ±0.1 % over voltage range

Insulation resistance: ≥ 100 MΩ with 500 V DC

Dielectric strength: 1500 V AC @ 1 minute

(input to output 1 or output 2 or power)

500 V AC @ 1 minute

(output 1 to output 2 to power)

1500 V AC @ 1 minute

(input or output or power to ground)

EXTERNAL DIMENSIONS unit: mm [inch]

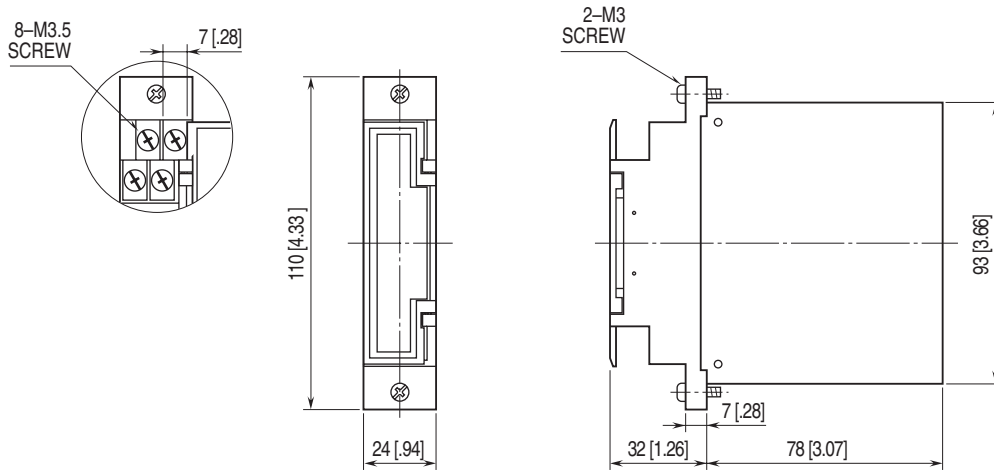

TERMINAL ASSIGNMENTS

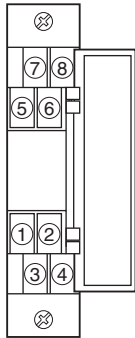

SCHEMATIC CIRCUITRY & CONNECTION DIAGRAM

■ When Used as Linearizer

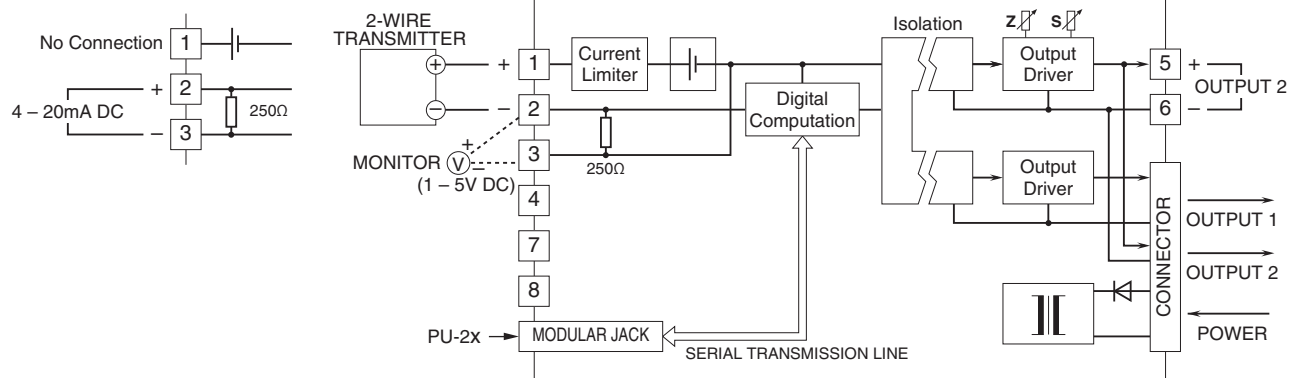

Specifications are subject to change without notice.