

Rack-mounted DCS Signal Conditioners 18-RACK

SIGNAL TRANSMITTER

(field-programmable)

Functions & Features

- Converting a DC input into two standard process signals
- Micro-processor based
- Field-programmable input range
- Loop testing via hand-held programmer PU-2x
- Second channel output available at the front terminals and at the Standard Rack connector

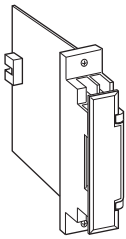

MODEL: 18JV-[1]66-R

ORDERING INFORMATION

- Code number: 18JV-[1]66-R
- Specify a code from below for [1].
(e.g. 18JV-U166-R)
- Special input range (For codes U1, U2 & U3)

[1] INPUT

Current

A: 4 - 20 mA DC (Input resistance 250 Ω)

H: 10 - 50 mA DC (Input resistance 100 Ω)

Voltage

6: 1 - 5 V DC (Input resistance 1 MΩ min.)

U1: Range ±100 mV;

(Minimum span 3 mV, Input resistance 20 kΩ min.)

U2: Range ±1000 mV;

(Minimum span 30 mV, Input resistance 20 kΩ min.)

U3: Range ±10 V;

(Minimum span 0.3 V, Input resistance 1 MΩ min.)

OUTPUT 1

Voltage

6: 1 - 5 V DC (Load resistance 2000 Ω min.)

OUTPUT 2

Voltage

6: 1 - 5 V DC (Load resistance 2000 Ω min.)

POWER INPUT

DC Power

R: 24 V DC

(Operational voltage range 24 V ±10 %, ripple 10 %p-p max.)

RELATED PRODUCTS

- Programming Unit (model: PU-2x)
- PC configurator software (model: JXCON)

Downloadable at our web site.

A dedicated cable is required to connect the module to the PC. Please refer to the internet software download site or the users manual for the PC configurator for applicable cable types.

GENERAL SPECIFICATIONS

Construction: Rack-mounted; terminal access via screw terminals on the front and connector on the rear; terminal cover provided

Connection

Input: M3.5 screw terminals (torque 0.8 N·m)

Output 1: Connector

Output 2: M3.5 screw terminals (torque 0.8 N·m)

and connector

Power input: Supplied from connector

Screw terminal: Nickel-plated steel

Isolation: Input to output 1 to output 2 to power

Overrange output: Approx. -10 to +120 % at 1 - 5 V

Adjustments: Programming Unit (model: PU-2x); Input range, zero and span, simulating output, etc.

(Input range can be changed with Codes U1, U2 or U3 and limited within ranges of each code type.)

(Refer to the users manual of JXCON for the adjustments configurable with JXCON.)

INPUT SPECIFICATIONS

■ **DC Current:** Input resistor incorporated

■ **DC Voltage:** -10 - +10 V DC

Minimum span: 3 mV

Offset: Max. 3 times span

Default setting will be used if not otherwise specified.

U1: 0 - 100 mV DC

U2: 0 - 1 V DC

U3: 0 - 10 V DC

OUTPUT SPECIFICATIONS

With the input voltage code 6, U3 (0 % ≥ 0 V) and current, the output goes below 0 % when the input is open.

INSTALLATION

Current consumption: Approx. 60 mA
Operating temperature: -5 to +55°C (23 to 131°F)
Operating humidity: 30 to 90 %RH (non-condensing)
Mounting: Standard Rack 18BXx or 18KBXx
Weight: 150 g (0.33 lb)

PERFORMANCE in percentage of span

Accuracy: $\pm 0.1\%$
Temp. coefficient: $\pm 0.015\%/^{\circ}\text{C}$ ($\pm 0.008\%/^{\circ}\text{F}$)
Response time: ≤ 0.5 sec. (0 - 90 %)
Line voltage effect: $\pm 0.1\%$ over voltage range
Insulation resistance: $\geq 100\ \text{M}\Omega$ with 500 V DC
Dielectric strength: 1500 V AC @ 1 minute
 (input to output 1 or output 2 or power)
 500 V AC @ 1 minute
 (output 1 to output 2 to power)
 1500 V AC @ 1 minute
 (input or output or power to ground)

EXTERNAL DIMENSIONS unit: mm [inch]

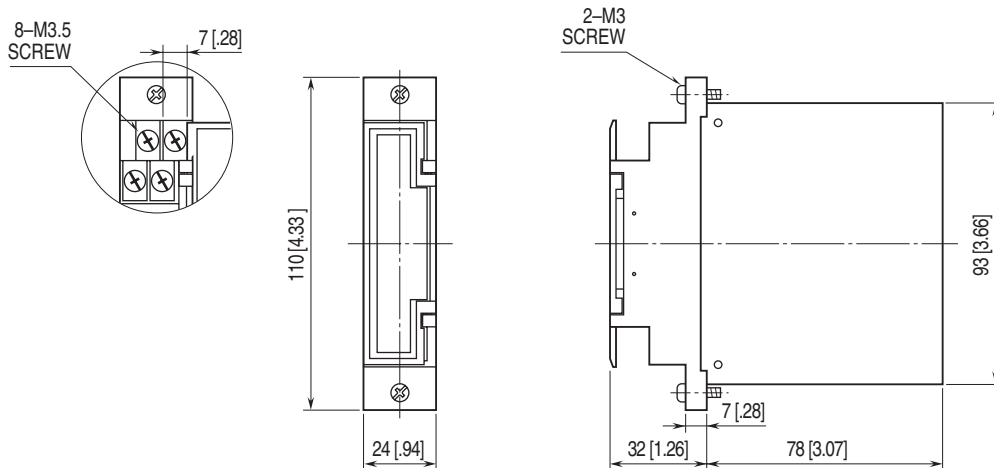

TERMINAL ASSIGNMENTS

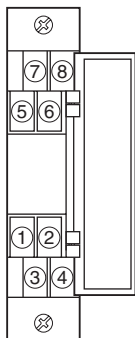

SCHEMATIC CIRCUITRY & CONNECTION DIAGRAM

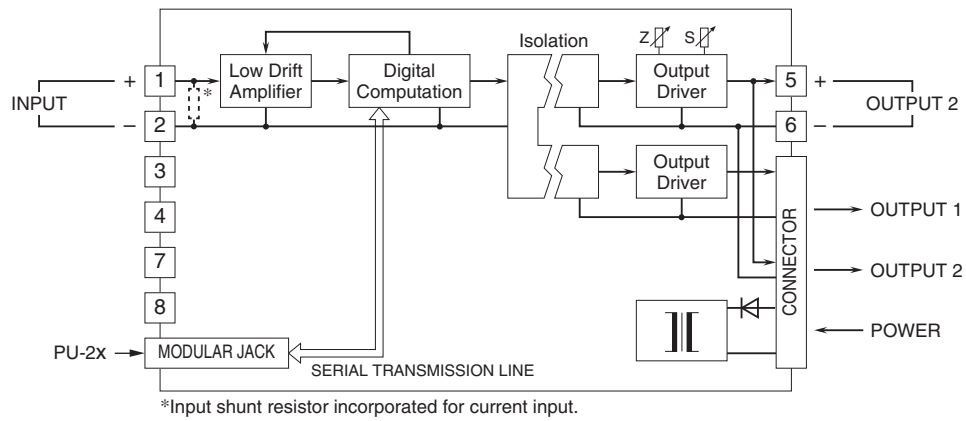

Specifications are subject to change without notice.