

Hybrid IC Isolation Amplifiers 20 Series

ISOLATION AMPLIFIER

(high-accuracy, input isolation, external synchronous)

Functions & Features

- Being used for printed wiring board installation
- Up to 1500 V isolation between input to output or power input
- High-linearity
- Small installation area in printed wiring board
- Gain adjustable range, $\times 1$ to $\times 10$
- Powered with external Clock Generator (model: 20VS5-2)

Typical Applications

- Isolating the field and input circuit of microprocessor to reduce noise from field
- Available for manufacturers of small-lot products to omit the development of isolation circuit
- Using external Clock Generator to eliminate the "beat frequency" interference at multi-channel outputs.

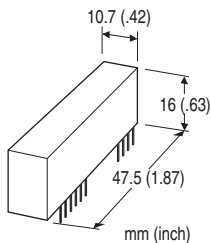

MODEL: 20VS5-213

ORDERING INFORMATION

- Code number: 20VS5-213

INPUT RANGE -10 - +10 V DC

OUTPUT RANGE -10 - +10 V DC

POWER INPUT

210 kHz (clock input)

0 - 15 V, square wave, duty cycle: 50 %

Supplied with external Clock Generator (model: 20VS5-2)

RELATED PRODUCTS

- Clock generator (model: 20VS5-2)

GENERAL SPECIFICATIONS

Construction: Hybrid IC

Housing material: Flame-resistant resin (black)

Isolation: Input to output or power

INPUT SPECIFICATIONS

■ DC Voltage

Input : -10 - +10 V DC

Input resistance: $\geq 1 \text{ M}\Omega$ (10 k Ω in power failure)

Overload input voltage: $\pm 30 \text{ V DC}$ continuous

Input offset voltage: $\pm 10 \text{ mV}$

Input bias current: 0.5 nA TYP. (@25°C)

OUTPUT SPECIFICATIONS

■ DC Voltage: -10 - +10 V DC

Load resistance: $\geq 5 \text{ k}\Omega$

Output impedance: $\leq 1 \Omega$

REFERENCE VOLTAGE SOURCE

Output voltage: $\pm 15 \text{ V DC TYP.}$

Load current: $\leq 2 \text{ mA}$

INSTALLATION

Power input

0 - 15 V $\pm 5 \%$, square wave, duty cycle: 50 % $\pm 5 \%$, 210 kHz $\pm 5 \%$; approx. 15 mA

Operating temperature: -10 to +70°C (14 to 158°F)

Operating humidity: 30 to 90 %RH (non-condensing)

Mounting: Soldering to the printed wiring board

Weight: 10 g (0.35 oz)

PERFORMANCE in percentage of span

Unless otherwise specified, $G = 1$.

Linearity: $\pm 0.005 \%$ TYP. ($\pm 0.01 \%$ max.)

Temp. coefficient: 40 ppm/°C

Frequency characteristics: Approx. 1 kHz, -3 dB

Response time: $\leq 450 \mu\text{sec.}$ (0 - 90 %)

Conversion gain: $\times 0.97 \pm 5 \%$

Gain adjustable range: $\times 1$ to $\times 10$

Line voltage effect: $\pm 0.05 \%$

(over voltage, duty cycle and frequency range)

Insulation resistance: $\geq 100 \text{ M}\Omega$ with 500 V DC

Dielectric strength: 1500 V AC @1 minute (input or reference voltage source to output or power)

CMRR: $\geq 110 \text{ dB}$ (500 V AC 50/60 Hz)

EXTERNAL DIMENSIONS & TERMINAL ASSIGNMENTS unit: mm [inch]

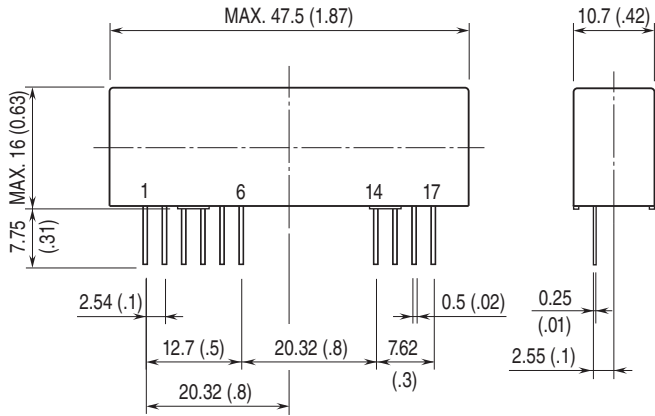

PIN ASSIGNMENT

1	FEEDBACK
2	INVERTING INPUT
3	NON-INVERTING INPUT
4	COM (-)
5	REFERENCE VOLTAGE SOURCE (+)
6	REFERENCE VOLTAGE SOURCE (-)
14	POWER SUPPLY (+) CLOCK INPUT [] 0-15V
15	POWER SUPPLY (-)
16	OUTPUT (-)
17	OUTPUT (+)

SCHEMATIC CIRCUITRY & CONNECTION DIAGRAM

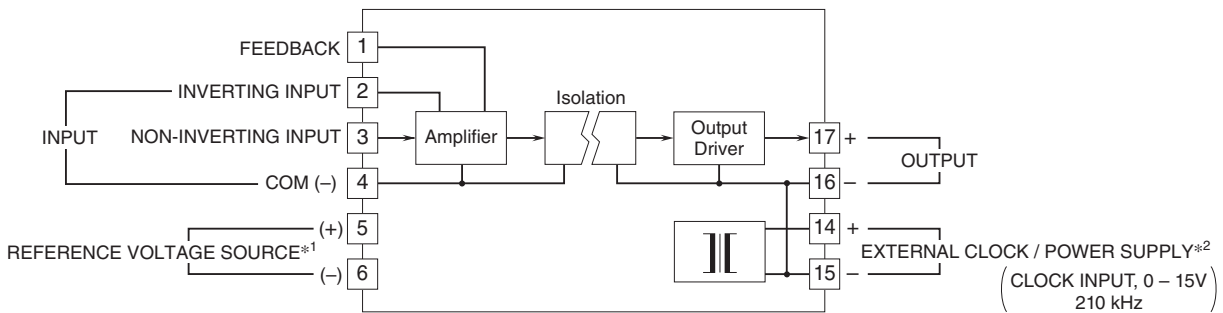

*1. To be used in the printed wiring board on which the unit is mounted.
 *2. It is available to drive with external Clock Generator (model: 20VS5-2).
 Note. The reference voltage source is common to the COM (-), terminal 4.

APPLICATION EXAMPLE

$$10 \text{ k}\Omega \leq (R_1 + R_2) \leq 200 \text{ k}\Omega$$

■ Non-inverting amplifier circuit: Basic example of $G = 0.97$

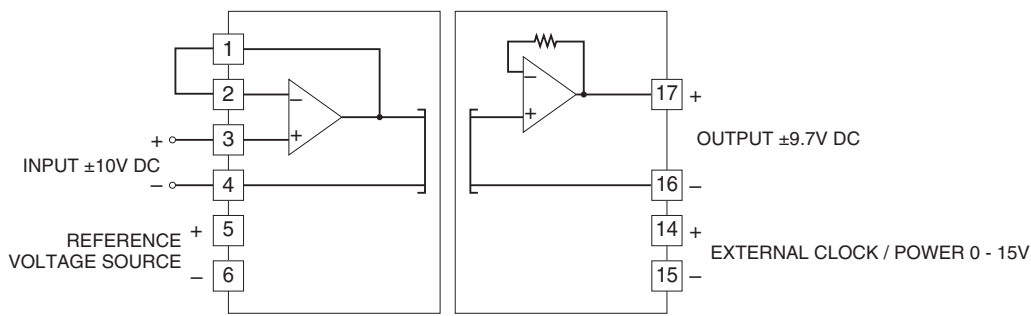

Non-inverting circuit $G = 0.97$

■ Inverting amplifier circuit: Basic example of $G = -1$ (output inverted to the input) ($R_1 \approx R_2$)

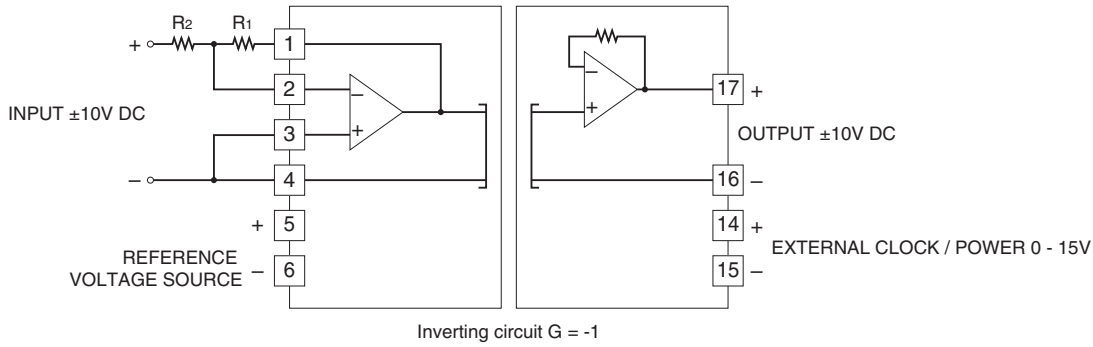

■ Non-inverting amplifier circuit: Example of $G = 1 + R_1 / R_2$

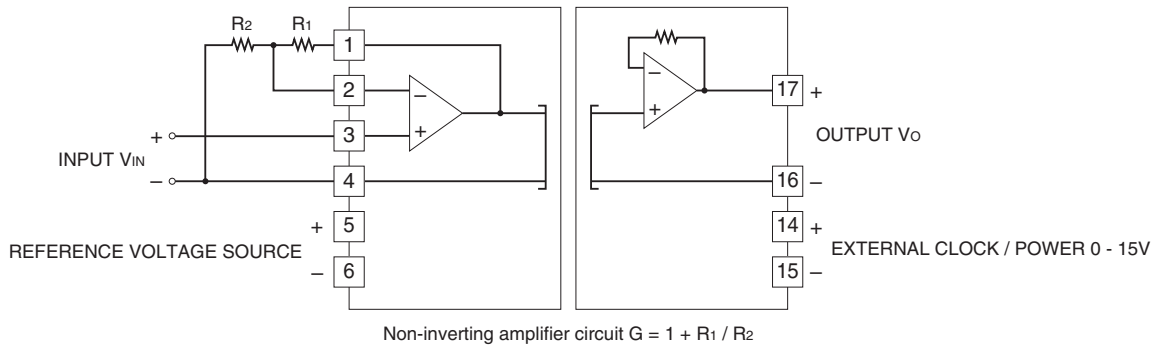

■ Inverting amplifier circuit: Example of $G = -R_1 / R_2$ (output inverted to the input)

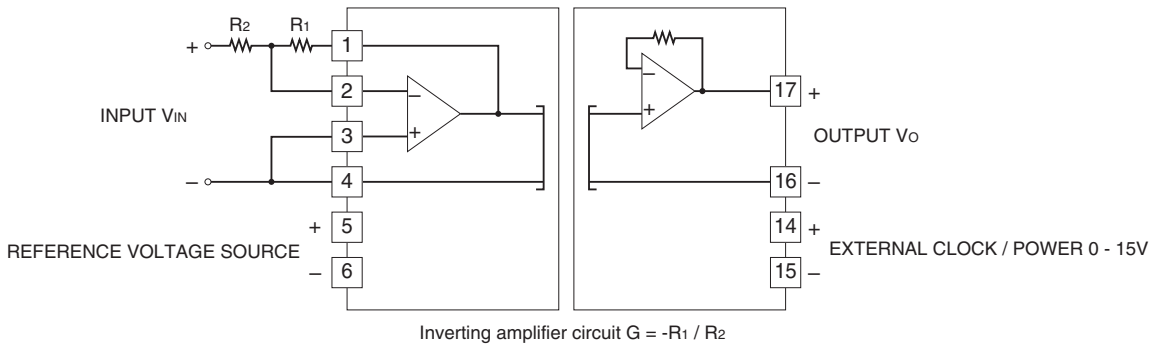

■ Non-inverting amplifier's circuit with external adjustments: Example of $G = 2$

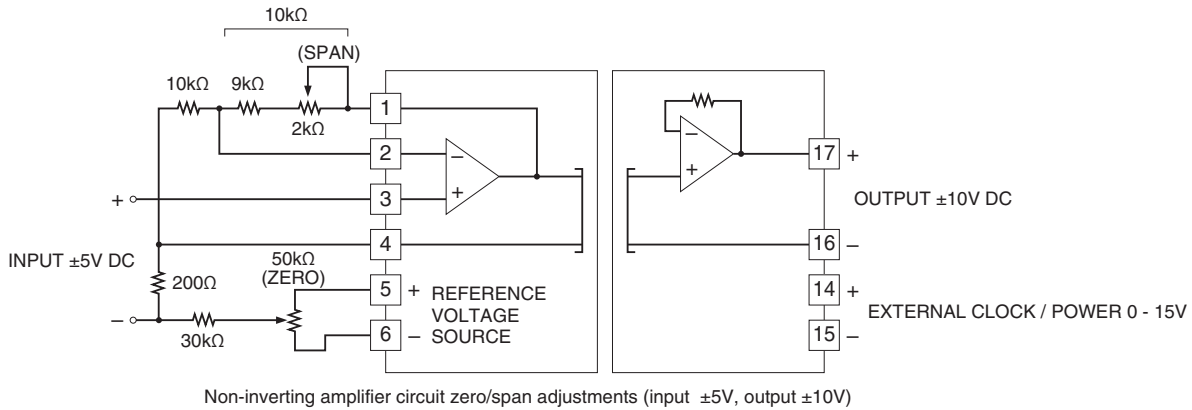

■ Inverting amplifier's circuit with external adjustments: Example of $G = -1$ (output inverted to the input)

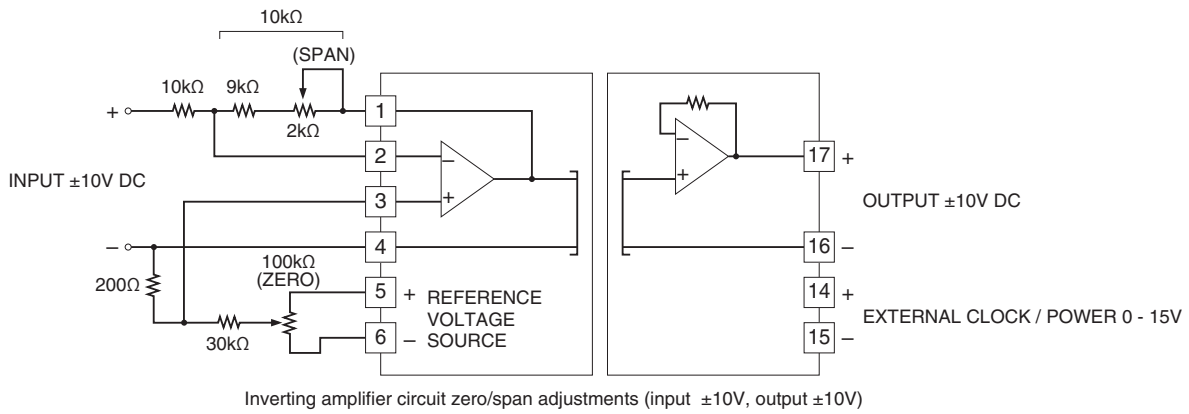

■ Multi-channel

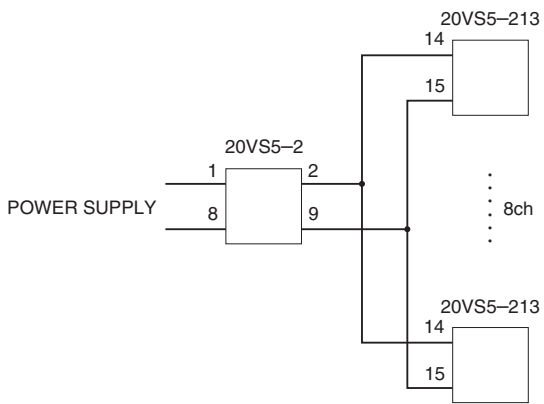

Specifications are subject to change without notice.