

Hybrid IC Isolation Amplifiers 20 Series

ISOLATION AMPLIFIER

(high-accuracy, input isolation)

Functions & Features

- Being used for printed wiring board installation
- Up to 1500 V AC isolation between input to output or power input
- High-linearity
- Small installation area in printed wiring board
- Gain adjustable range, $\times 1$ to $\times 100$
- Power 15 V DC

Typical Applications

- Galvanically isolating the I/O circuits of microprocessor from the field side to reduce external noise
- Enabling electronic manufacturers to save efforts and cost for the development of isolation circuits for small-lot products

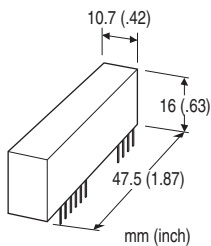

MODEL: 20VS5-G200-U

ORDERING INFORMATION

- Code number: 20VS5-G200-U

INPUT RANGE -5 - +5 V DC

OUTPUT RANGE -5 - +5 V DC

POWER INPUT

DC Power

U: 15 V DC

GENERAL SPECIFICATIONS

Construction: Hybrid IC

Housing material: Flame-resistant resin (black)

Isolation: Input to output or power

INPUT SPECIFICATIONS

■ DC Voltage

Input : -5 - +5 V DC

Input resistance: $\geq 1 \text{ M}\Omega$ (10 k Ω in power failure)

Overload input voltage: 15 V DC continuous

Input offset voltage: $\pm 15 \text{ mV}$

Input bias current: 0.5 nA TYP. (@25°C)

OUTPUT SPECIFICATIONS

■ **DC Voltage:** -5 - +5 V DC

Load resistance: $\geq 12 \text{ k}\Omega$

Output impedance: $\leq 1 \Omega$

REFERENCE VOLTAGE SOURCE

Output voltage: $\pm 7 \text{ V DC TYP.}$

Load current: $\leq 2 \text{ mA}$

INSTALLATION

Power input

- **DC:** Operational voltage range: Rating $\pm 10 \%$, ripple 2 %p-p max.; approx. 7 mA with no load

Operating temperature: -10 to +70°C (14 to 158°F)

Operating humidity: 30 to 90 %RH (non-condensing)

Mounting: Soldering to the printed wiring board

Weight: 13 g (0.46 oz)

PERFORMANCE in percentage of span

Unless otherwise specified, $G = 1$.

Linearity: $\pm 0.005 \%$ TYP. ($\pm 0.01 \%$ max.)

Temp. coefficient:

Offset drift 20 ppm/°C

Span drift 40 ppm/°C

Frequency characteristics: Approx. 3 kHz, -3 dB

Response time: $\leq 150 \mu\text{sec.}$ (0 - 90 %)

Conversion gain: $\times 0.98 \pm 5 \%$

Gain adjustable range: $\times 1$ to $\times 100$

Line voltage effect: $\pm 0.05 \%$ over voltage range

Insulation resistance: $\geq 100 \text{ M}\Omega$ with 500 V DC

Dielectric strength: 1500 V AC @1 minute (input or reference voltage source to output or power)

CMRR: $\geq 100 \text{ dB}$ (500 V AC 50/60 Hz)

■ Inverting amplifier circuit: Basic example of $G = -1$ (output inverted to the input) ($R_1 \approx R_2$)

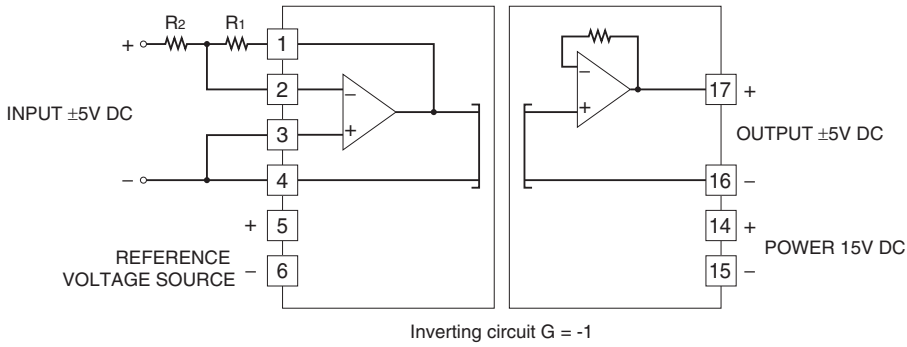

■ Non-inverting amplifier circuit: Example of $G = 1 + R_1 / R_2$

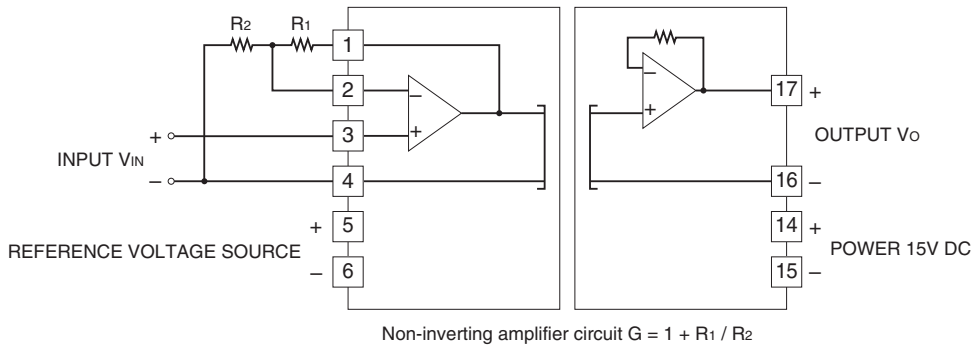

■ Inverting amplifier circuit: Example of $G = -R_1 / R_2$ (output inverted to the input)

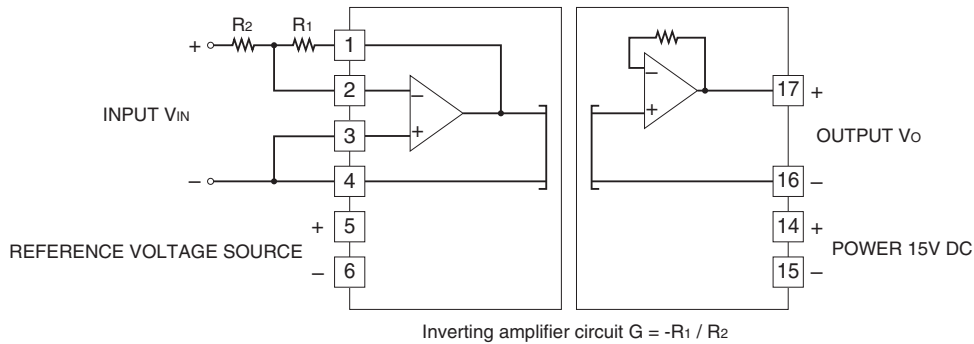

■ Non-inverting amplifier's circuit with external adjustments: Example of $G = 2$

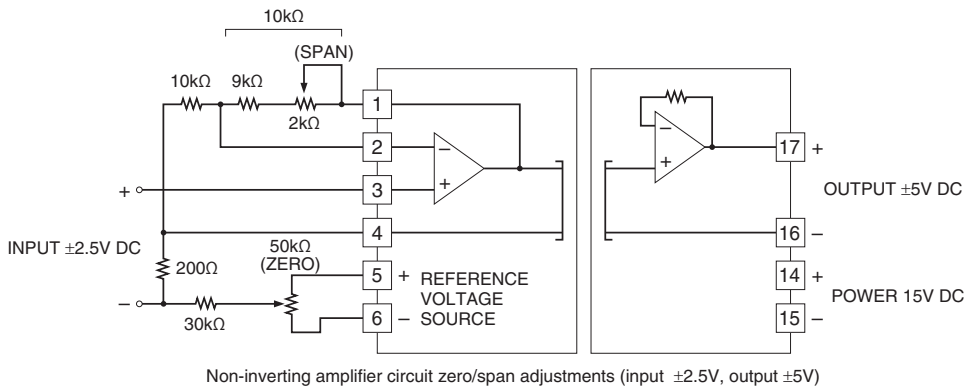

■ Inverting amplifier's circuit with external adjustments: Example of $G = -1$ (output inverted to the input)

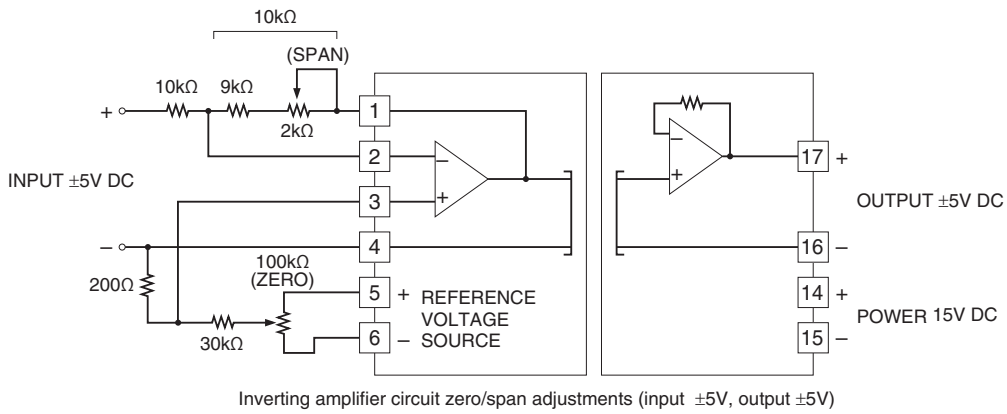

Specifications are subject to change without notice.