

Head-mounted Two-wire Signal Conditioners 27-UNIT

2-WIRE UNIVERSAL TEMPERATURE TRANSMITTER (HART communication)

Functions & Features

- Universal input: DC mV, T/C, RTD and resistance
- High accuracy
- HART communication
- Intrinsically safe approval
- Suitable for Functional Safety applications up to SIL2
- Programming via hand-held communicator or via PC
- A wide variety of T/C and RTD types
- User's temperature table can be used
- Self diagnostics
- Ultra-low temp. drift option (20 ppm/°C typ.)
- CE marking (conforms to ATEX and EMC)

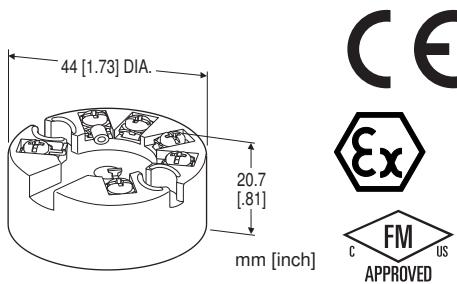

MODEL: 27HU-[1][2]

ORDERING INFORMATION

- Code number: 27HU-[1][2]
- Specify a code from below for each of [1] and [2].
(e.g. 27HU-2/L)
- Use Ordering Information Sheet (No. ESU-7651). Factory standard setting will be used if not otherwise specified.
Specify the country in which the product is to be used with the Safety Approval code 2.

[1] SAFETY APPROVAL

- 0: None
- 1: FM intrinsically safe
- 2: ATEX intrinsic safety

[2] OPTIONS

- Temperature Drift
- Blank:** Standard (temp. coefficient 0.015%/°C)
- /L:** Ultra-low temperature drift (temp. coefficient 0.002%/°C typ., 0.005%/°C max.)

RELATED PRODUCTS

- USB interface Bell202 modem (model: COP-HU)
Usable in 'non-hazardous' area only.
- Hand-held communicator
- PC configurator software (model: 27HUCFG)
Downloadable at our web site.

GENERAL SPECIFICATIONS

- Construction:** Sensor head-mounting
 - Connection:** M3 screw terminals (torque 0.5 N·m)
 - Screw terminal:** Nickel-plated brass
 - Housing material:** Flame-resistant resin (black)
 - Isolation:** Input to output
 - User-configurable items:**
 - Input sensor type and numbers
 - Number of wires (RTD & resistance)
 - Input range (inverted range selectable)
 - Burnout
 - Output limits (Upper / Lower)
 - Damping time (factory set to 0)
 - Cold junction compensation (T/C; internal or external sensor selectable)
 - Linearization
 - Sensor calibration
 - Output calibration
 - HART communication mode
- Refer to the HART setup manual or the PC configurator users manual for the detail.

HART COMMUNICATION

- Protocol:** HART communication protocol
- HART address range:** 0 - 15 (factory set to 0)
- Transmission speed:** 1200 bps
- Digital current:** Approx. 1 mA_{p-p} when communicating
- Character format:** 1 Start Bit, 8 Data Bits, 1 Odd Parity Bit, 1 Stop Bit
- Distance:** 1.5 km (0.9 miles)
- HART communication mode:** Master-Slave Mode and Burst Mode (factory set to Master-Slave)
- HART network mode:** Point-to-Point Mode and Multi-drop Mode; automatically set to Multi-drop Mode when the address is set to other than 0.

INPUT SPECIFICATIONS

- The input is factory set for use with K thermocouple, single input, 0 to 100°C, internal CJC sensor.
- See Table 1 for the available input type, the minimum span and the maximum range.
- **DC mV (dual input available)**
- Input resistance:** ≥ 1 MΩ
- **Thermocouple (dual input available)**

Input resistance: $\geq 1 \text{ M}\Omega$
Burnout sensing: 33 μA
External CJC sensor type: Pt 100
■ RTD (2-wire, 3-wire or 4-wire)
Input resistance: $\geq 1 \text{ M}\Omega$
Excitation: 0.2 mA
Allowable leadwire resistance: Max. 10 Ω per wire
■ Resistance (2-wire, 3-wire or 4-wire)
Input resistance: $\geq 1 \text{ M}\Omega$
Excitation: 0.2 mA
Allowable leadwire resistance: Max. 10 Ω per wire

OUTPUT SPECIFICATIONS

Output range: 4 - 20 mA DC
Operational range: 3.75 - 23 mA
Load resistance vs. supply voltage:
 Load Resistance (Ω) = (Supply Voltage (V) - 8 (V))
 $\div 0.023$ (A) (including leadwire resistance)
Burnout: 3.75 - 3.8 mA or 21.5 - 23 mA
 (factory set to 23 mA)
Upper output limit proportional to the input:
 20 - 21.5 mA (factory set to 21.5 mA)
Lower output limit proportional to the input:
 3.8 - 4 mA (factory set to 3.8 mA)
Update time: 440 msec. (660 msec. with dual input)
Output characteristics for dual input:
 Average or Differential selectable

INSTALLATION

Supply voltage

- 8 - 35 V DC (non-approved)
- 8 - 28 V DC (approved)

Operating temperature: -40 to +85°C (-40 to +185°F)
 (See Safety Parameters for use in a hazardous location.)
Operating humidity: 0 to 95 %RH (non-condensing)
Mounting: Head-mounting (DIN type B head)
Weight: 50 g (1.76 oz)

PERFORMANCE

Accuracy: See Table 1.
Cold junction compensation accuracy: $\pm 0.5^\circ\text{C}$ ($\pm 0.9^\circ\text{F}$) with internal CJC sensor
Response time: ≤ 2 sec. (0 - 90 %) with damping time set to 0 and when not communicating via HART.
Supply voltage effect: ± 0.005 % of span/V
Insulation resistance: $\geq 100 \text{ M}\Omega$ with 500 V DC
Dielectric strength: 1500 V AC @1 minute (input to output)
Safety integrity level according to IEC 61508: Suitable for use in a safety instrumented system up to SIL2 (together with sensor) if appropriate safety instructions are observed. Consult us.

STANDARDS & APPROVALS

EU conformity:
 ATEX Directive
 Ex ia EN 60079-11
 EMC Directive
 EN 61326-1
 RoHS Directive
Safety approval:
 FM: Intrinsically safe
 Class I, Division 1, Groups A, B, C and D
 Class I, Zone 0, AEx ia IIC (US)
 Class I, Zone 0, Ex ia IIC (Canada)
 T4, T5 and T6
 (Class 3610, ANSI/ISA 60079-11,
 CAN/CSA-C22.2 No. 157,
 CAN/CSA-C22.2 No. 60079-11)
 ATEX: Intrinsic safety
 Ⓔ II 1G, Ex ia IIC; T4, T5 and T6 Ga
 (EN 60079-0)
 (EN 60079-11)

SAFETY PARAMETERS

Operating temperature

For ATEX / FM:

T4: -40 to +80°C

T5: -40 to +60°C

T6: -40 to +45°C

Ex-data:

- Output circuit
 U_i (Vmax): 30 V DC
 I_i (Imax): 96 mA DC
 P_i (Pmax): 720 mW
 C_i : 1 nF
 L_i : 0 mH
- Sensor circuit
 U_o (Voc): 30 V DC
 I_o (Isc): 24 mA DC
 P_o : 180 mW
 C_o (Ca): 50 nF
 L_o (La): 40 mH

INPUT TYPE, RANGE & ACCURACY

INPUT TYPE				MINIMUM SAPN	MAXIMUM SPAN	ACCURACY *1	TEMPERATURE DRIFT	
							STANDARD DRIFT *2	ULTRA-LOW DRIFT *3
DC mV				4 mV	-100 to +800 mV	±10 µV	±1.5 µV/°C	±0.5 µV/°C
Resistance				25 Ω	0 to 4 kΩ	±0.1 Ω	±15 mΩ/°C	±5 mΩ/°C
Thermocouple	°C			°F			TEMPERATURE DRIFT	
	MINIMUM SAPN	MAXIMUM RENG	ACCURACY *1	MINIMUM SAPN	MAXIMUM RENG	ACCURACY *1	STANDARD DRIFT *2	ULTRA-LOW DRIFT *3
K (CA)	50	-180 to +1372	±0.5	90	-292 to +2501	±0.9	±0.075°C/°C	±0.025°C/°C
E (CRC)	50	-100 to +1000	±0.5	90	-148 to +1832	±0.9	±0.075°C/°C	±0.025°C/°C
J (IC)	50	-100 to +1200	±0.5	90	-148 to +2192	±0.9	±0.075°C/°C	±0.025°C/°C
T (CC)	50	-200 to +400	±0.5	90	-328 to +752	±0.9	±0.075°C/°C	±0.025°C/°C
B (RH)	100	400 to 1820	±1	180	752 to 3308	±1.8	±0.3°C/°C	±0.1°C/°C
R	100	-50 to +1760*4	±1	180	-58 to +3200*4	±1.8	±0.3°C/°C	±0.1°C/°C
S	100	-50 to +1760*4	±1	180	-58 to +3200*4	±1.8	±0.3°C/°C	±0.1°C/°C
C (WRe 5-26)	100	0 to 2300	±1	180	32 to 4172	±1.8	±0.3°C/°C	±0.1°C/°C
D (WRe 3-25)	100	0 to 2300	±1	180	32 to 4172	±1.8	±0.3°C/°C	±0.1°C/°C
N	50	-180 to +1300	±0.5	90	-292 to +2372	±0.9	±0.075°C/°C	±0.025°C/°C
U	50	-200 to +600	±0.5	90	-328 to +1112	±0.9	±0.075°C/°C	±0.025°C/°C
L	50	-100 to +900	±0.5	90	-148 to +1652	±0.9	±0.075°C/°C	±0.025°C/°C
RTD	°C			°F			TEMPERATURE DRIFT	
	MINIMUM SAPN	MAXIMUM RENG	ACCURACY *1	MINIMUM SAPN	MAXIMUM RENG	ACCURACY *1	STANDARD DRIFT *2	ULTRA-LOW DRIFT *3
Pt 100 (JIS '97, IEC)	10	-200 to +850	±0.1	18	-328 to +1562	±0.18	±0.015°C/°C	±0.005°C/°C
Pt 200	10	-200 to +850	±0.1	18	-328 to +1562	±0.18	±0.015°C/°C	±0.005°C/°C
Pt 500	10	-200 to +850	±0.1	18	-328 to +1562	±0.18	±0.015°C/°C	±0.005°C/°C
Pt 1000	10	-200 to +850	±0.1	18	-328 to +1562	±0.18	±0.015°C/°C	±0.005°C/°C
JPt 100 (JIS '89)	10	-200 to +510	±0.1	18	-328 to +950	±0.18	±0.015°C/°C	±0.005°C/°C
Ni 100 (DIN 43760 '87)	10	-60 to +250	±0.2	18	-76 to +482	±0.36	±0.015°C/°C	±0.005°C/°C

- *1. DC mV: Or ±0.05 % of absolute range (greater of 0 % and 100 % range values), whichever is greater.
 Or ±0.2 % of absolute negative range for two inputs including negative ranges, whichever is greater.
- Resistance: Or ±0.05 % of absolute range (greater of 0 % and 100 % range values), whichever is greater.
- Thermocouple: Or ±0.05 % of span, whichever is greater. Add cold junction compensation error.
- RTD: Or ±0.05 % of max. range (greater of 0 % and 100 % range values converted into °C), whichever is greater.
 (For 2- or 3-wire RTD, the value is valid by the sensor calibration after wiring is complete.)
- *2. Or ±0.015 % of absolute range/°C (greater of 0 % and 100 % range values), whichever is greater.
- *3. Or ±0.005 % of absolute range/°C (greater of 0 % and 100 % range values), whichever is greater.
- *4. Conformance range: 50 to 1760°C or 122 to 3200°F

EXTERNAL DIMENSIONS & TERMINAL ASSIGNMENTS unit: mm [inch]

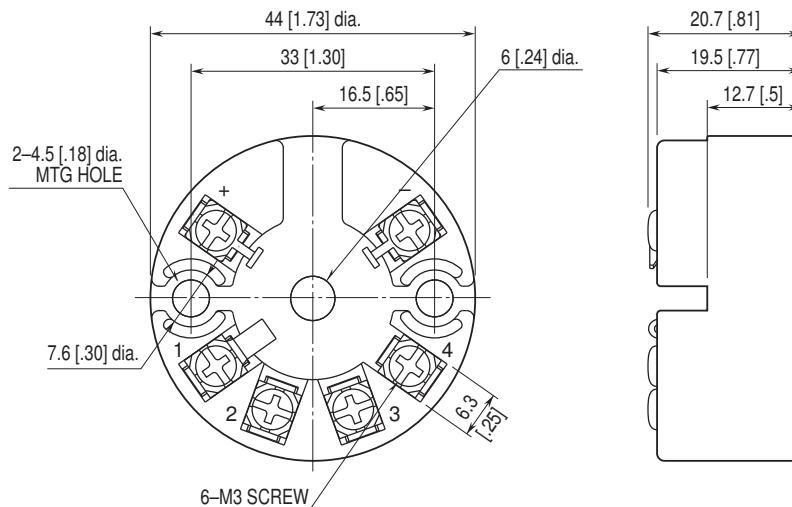

MOUNTING REQUIREMENTS unit: mm [inch]

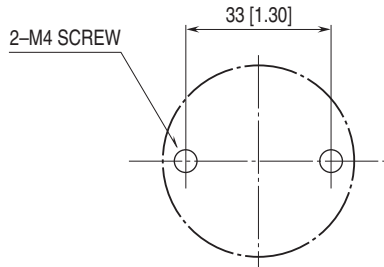

The screws are to be provided by the customer.

SCHEMATIC CIRCUITRY & CONNECTION DIAGRAM

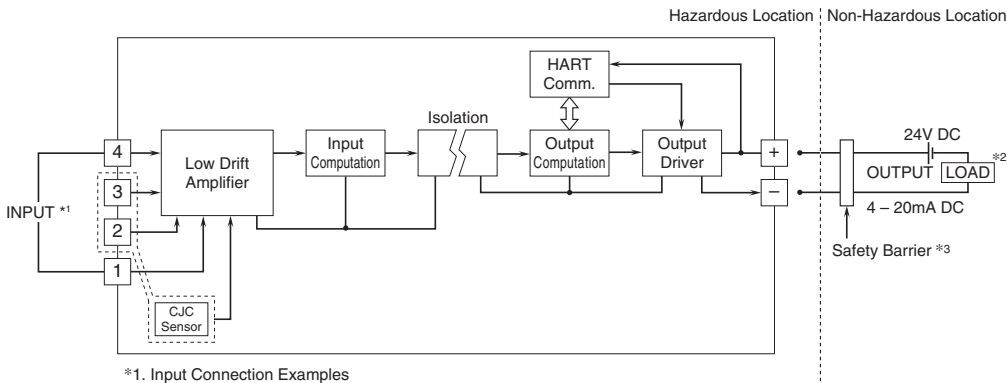

■ DC MILLIVOLT

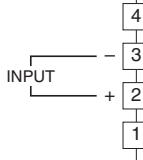

• Two Inputs

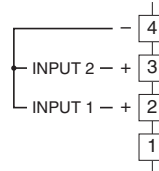

■ THERMOCOUPLE

• Internal CJC

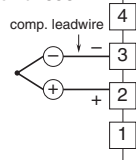

• External CJC

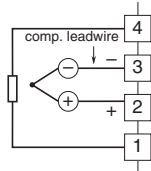

■ RTD & RESISTANCE

• Two-wire

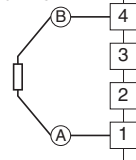

• Three-wire

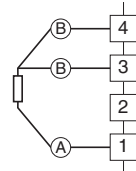

• Two Inputs, Internal CJC

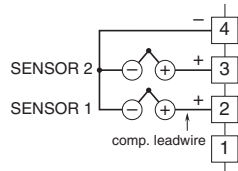

• Four-wire

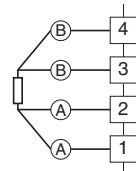

• Two Inputs, External CJC

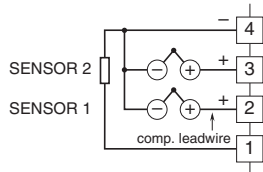

*2. Limited to 250 – 1100Ω for HART communication.

*3. A safety barrier must be installed for the intrinsic safety.

The safety barrier must meet the Ex-data of this unit and must be approved for the hazardous location.



Specifications are subject to change without notice.