

Digital Panel Meters 40 Series

DC INPUT DIGITAL PANEL METER

(4 digits, process meter)

Functions & Features

- 4 digit (± 9999) panel meter
- Scaling and HOLD functions
- High visible, 0.8" (20.3mm) high and bright LED

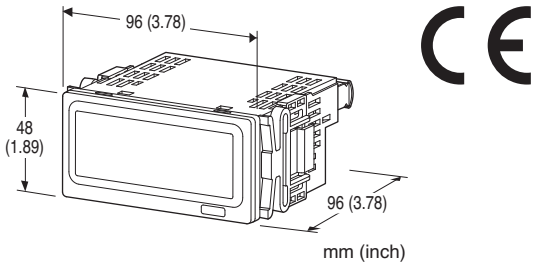

MODEL: 40DV1-[1]-[2][3]

ORDERING INFORMATION

- Code number: 40DV1-[1]-[2][3]
- Specify a code from below for each of [1] through [3].
(e.g. 40DV1-V1-M2/Q)
- Specify the specification for option code /Q
(e.g. /C01/SET)

[1] INPUT

Current

- A1:** $\pm 199.9 \mu\text{A}$ DC (Conformance range)
(Input range: Approx. $-219 - +219 \mu\text{A}$, Input resistance: 1 k Ω)
 - A2:** $\pm 1.999 \text{ mA}$ DC (Conformance range)
(Input range: Approx. $-2.19 - +2.19 \text{ mA}$, Input resistance: 1 k Ω)
 - A3:** $\pm 19.99 \text{ mA}$ DC (Conformance range)
(Input range: Approx. $-21.9 - +21.9 \text{ mA}$, Input resistance: 10 Ω)
 - A4:** $\pm 199.9 \text{ mA}$ DC (Conformance range)
(Input range: Approx. $-219 - +219 \text{ mA}$, Input resistance: 1 Ω)
 - A:** 4.00 – 20.00 mA DC (Conformance range)
(Input range: Approx. 2.4 – 21.6 mA, Input resistance: 10 Ω)
- Voltage
- V1:** $\pm 199.9 \text{ mV}$ DC (Conformance range)
(Input range: Approx. $-219 - +219 \text{ mV}$, Input resistance: $\geq 1 \text{ M}\Omega$)
 - V2:** $\pm 1.999 \text{ V}$ DC (Conformance range)
(Input range: Approx. $-2.19 - +2.19 \text{ V}$, Input resistance: $\geq 1 \text{ M}\Omega$)
 - V3:** $\pm 19.99 \text{ V}$ DC (Conformance range)
(Input range: Approx. $-21.9 - +21.9 \text{ V}$, Input resistance: $\geq 1 \text{ M}\Omega$)
 - V4:** $\pm 199.9 \text{ V}$ DC (Conformance range)
(Input range: Approx. $-219 - +219 \text{ V}$, Input resistance: $\geq 4 \text{ M}\Omega$)

V5: $\pm 600 \text{ V}$ DC (Conformance range)

(Input range: Approx. $-659 - +659 \text{ V}$, Input resistance: $\geq 4 \text{ M}\Omega$)
(CE not available)

6: 1.00 – 5.00 V DC (Conformance range)

(Input range: Approx. 0.6 – 5.4 V, Input resistance: $\geq 1 \text{ M}\Omega$)

[2] POWER INPUT

AC Power

M2: 100 – 240 V AC (Operational voltage range 85 – 264 V, 50/60 Hz)

DC Power

R: 24 V DC

(Operational voltage range 24 V $\pm 20 \%$, ripple 10 %p-p max.)

[3] OPTIONS

blank: none

/Q: With options (specify the specification)

SPECIFICATIONS OF OPTION: Q (multiple selections)

COATING (For the detail, refer to our web site.)

Moving parts and indicators are not coated.

/C01: Silicone coating

/C02: Polyurethane coating

/C03: Rubber coating

EX-FACTORY SETTING

/SET: Preset according to the Ordering Information Sheet
(No. ESU-9539)

GENERAL SPECIFICATIONS

Construction: Panel flush mounting

Connection: M3 screw terminals (torque 0.6 N·m)

Solderless terminal: Refer to the drawing at the end of the section.

Recommended manufacturer: Japan Solderless Terminal MFG.Co.Ltd, Nichifu Co.,Ltd

Applicable wire size: 0.25 to 1.65 mm² (AWG 22 to 16)

Screw terminal: Nickel-plated steel

Housing material: Flame-resistant resin (gray)

Isolation: Input to power

A/D conversion: $\Sigma - \Delta$

Sampling rate: 10 times/sec. (100 msec.)

Averaging: None or moving average

Setting: (Front button)

- Scaled range
- Moving average
- Brightness
- Others

■ Recommended solderless terminal

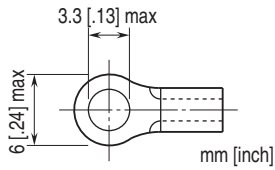

DISPLAY

Display: 4 digits of 20.3 mm (0.8 inch) height, 7-segment, red LED

Display range: -9999 to 9999

Scaling range for measurement range (conformance range): -9999 to 9999 counts

Decimal point position: 10^{-1} , 10^{-2} , 10^{-3} or none

Zero indication: Higher-digit zeros are suppressed.

Over-range indication: '-9999' or '9999' blinking for display values out of the display range. 'S.ERR' blinks surpassing the permissible range.

Engineering unit indication: Sticker label attached

DC, AC, mV, V, kV, μ A, mA, A, kA, mW, W, kW, var, kvar, Mvar, VA, Hz, Ω , k Ω , M Ω , cm, mm, m, m/sec, mm/min, cm/min, m/min, m/h, m/s², inch, l, l/s, l/min, l/h, m³, m³/sec, m³/min, m³/h, Nm³/h, N·m, N/m², g, kg, kg/h, N, kN, Pa, kPa, MPa, t, t/h, °C, °F, %RH, J, kJ, MJ, rpm, sec, min, pH, %, ppm, etc.

INPUT SPECIFICATIONS

■ **DC Current:** Input resistor incorporated

■ **Hold Input:** Dry contact input

Detecting voltage/current: approx. 4.7 V / approx. 0.05 mA

Detecting level voltage/resistance:

Hi level: ≥ 2.1 V / ≥ 73.8 k Ω

Lo level: ≤ 0.7 V / ≤ 16.6 k Ω

HOLD at Lo level

INSTALLATION

Power consumption

•AC: ≤ 2.7 VA

•DC: Approx. 0.5 W

Operating temperature: -10 to +55°C (14 to 131°F)

Operating humidity: 30 to 90 %RH (non-condensing)

Mounting: Panel flush mounting

Weight: 160 g (0.35 lb)

PERFORMANCE

Accuracy (for each input code)

A1: ± 0.1 % rdg ± 1 digit

A2: ± 0.1 % rdg ± 1 digit

A3: ± 0.1 % rdg ± 1 digit

A4: ± 0.1 % rdg ± 1 digit

A: ± 0.1 % rdg ± 1 digit

V1: ± 0.1 % rdg ± 1 digit

V2: ± 0.1 % rdg ± 1 digit

V3: ± 0.1 % rdg ± 1 digit

V4: ± 0.1 % rdg ± 1 digit

V5: ± 0.15 % rdg ± 1 digit

6: ± 0.1 % rdg ± 1 digit

("1 digit" is multiplied by scaling-multiple. Even in case the scaling-multiple is less than 1, multiply by 1.)

Temp. coefficient: $\pm(0.01$ % rdg +0.3 digits)/°C

("0.3 digits" is multiplied by scaling-multiple. Even in case the scaling-multiple is less than 1, multiply by 1.)

Scaling-multiple = | (Display Scaling Value B - Display Scaling Value A) \div (default Display Scaling Value B - default Display Scaling Value A) |

Line voltage effect: ± 1 digit over voltage range

Insulation resistance: ≥ 100 M Ω with 500 V DC

Dielectric strength: 1500 V AC @1 minute (input to power to ground)

STANDARDS & APPROVALS

EU conformity:

EMC Directive

EN 61326-1

Low Voltage Directive

EN 61010-1

Measurement Category I (input)

Installation Category II (power)

Pollution degree 2

Input to power: Reinforced insulation (300 V)

RoHS Directive

DISPLAY HOLD COMMAND

Displayed value is held with an external HOLD command input. Connect the contacts across HOLD to COM.

■ WIRING EXAMPLES

(a) 5V-CMOS, TTL

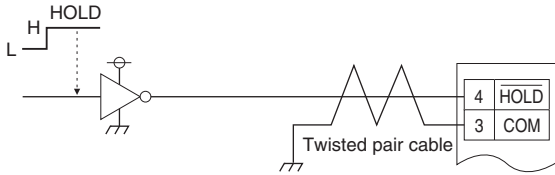

(c) Photo-Coupler

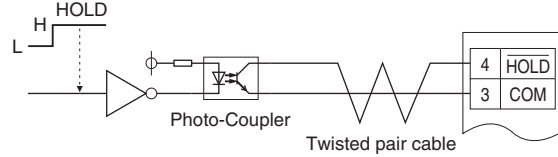

(b) Transistor

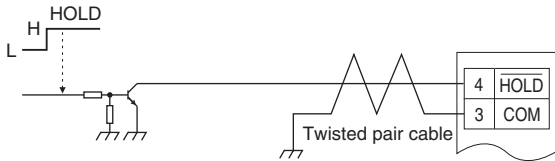

(d) Relay

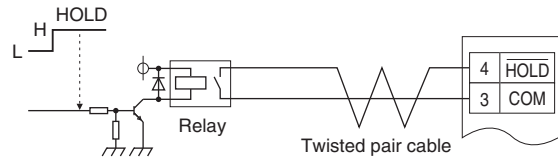

Terminals 3 and 4 are NOT isolated from the internal circuit.

EXTERNAL VIEW

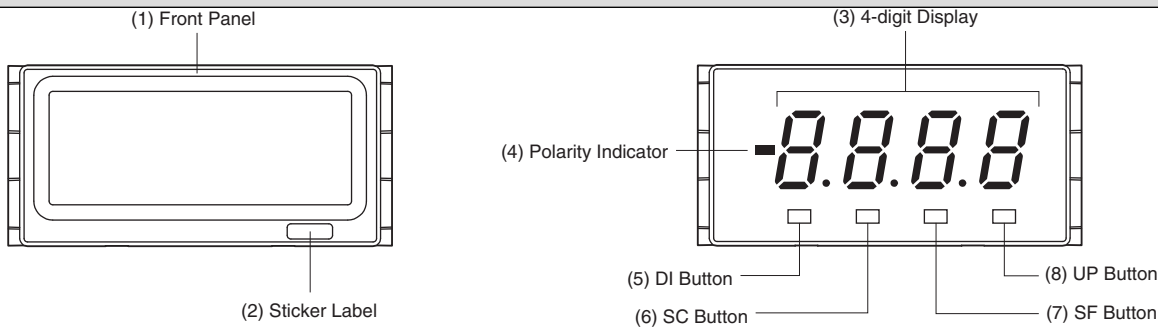

■ COMPONENT IDENTIFICATION

No.	COMPONENT	FUNCTIONS
(1)	Front panel	Removed at configuration.
(2)	Sticker label	Engineering unit label position
(3)	4-digit display	4-digit LED display. Range: 0 to 9999 (not including decimal point)
(4)	Polarity indicator	Turns on when negative value is displayed
(5)	DI button	Used to move on to the display setting modes; or to shift through setting items in each setting mode.
(6)	SC button	Used to move on to the scaling setting modes; or to shift through setting items in each setting mode.
(7)	SF button	Used to move on to the setting standby status and shift through display digits in each setting item.
(8)	UP button	Used to select setting value.

PARAMETER LIST

■ SCALING SETTING MODE

PARAMETER	SETTING PARAMETER	INPUT CODE	DISPLAY	DESCRIPTION	DEFAULT VALUE
Input scaling value zero	i Er	A1	- 1999 ~ 1999	Input value setting for display scaling value zero. Configurable by parameter or teach calibration.	- 1999
		A2	- 1999 ~ 1999		- 1999
		A3	- 1999 ~ 1999		- 1999
		A4	- 1999 ~ 1999		- 1999
		A	0400 ~ 2000		0400
		V1	- 1999 ~ 1999		- 1999
		V2	- 1999 ~ 1999		- 1999
		V3	- 1999 ~ 1999		- 1999
		V4	- 1999 ~ 1999		- 1999
		V5	-0600 ~ 0600		-0600
6	0 100 ~ 0500	0 100			
Input scaling value span	i SP	A1	- 1999 ~ 1999	Input value setting for display scaling value span. Configurable by parameter or teach calibration.	1999
		A2	- 1999 ~ 1999		1999
		A3	- 1999 ~ 1999		1999
		A4	- 1999 ~ 1999		1999
		A	0400 ~ 2000		2000
		V1	- 1999 ~ 1999		1999
		V2	- 1999 ~ 1999		1999
		V3	- 1999 ~ 1999		1999
		V4	- 1999 ~ 1999		1999
		V5	-0600 ~ 0600		0600
6	0 100 ~ 0500	0500			
Display scaling value zero	d Er	A1	- 9999 ~ 9999	Display value setting for input scaling value zero.	- 1999
		A2			- 1999
		A3			- 1999
		A4			- 1999
		A			0400
		V1			- 1999
		V2			- 1999
		V3			- 1999
		V4			- 1999
		V5			-0600
6		0 100			
Display scaling value span	d SP	A1	- 9999 ~ 9999	Display value setting for input scaling value span	1999
		A2			1999
		A3			1999
		A4			1999
		A			2000
		V1			1999
		V2			1999
		V3			1999
		V4			1999
		V5			0600
6		0500			
Decimal point	d Pt	A1	Fourth to second digit, None	Decimal point setting.	8888
		A2			8888
		A3			8888
		A4			8888
		A			8888
		V1			8888
		V2			8888
		V3			8888
		V4			8888
		V5			8888
6	8888				

• **Normal Scaling**

The display value increases when the input signal increases.

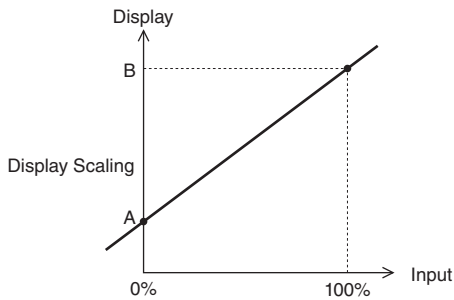

• **Inverted Scaling**

The display value decreases when the input signal increases.

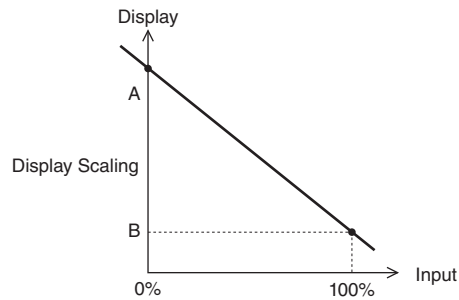

The decimal point position can be set to any digit. Set it according to the 100% value.

· Teach calibration

Using the parameters "input scaling value zero" and "input scaling value span," the 0 % and 100 % of the input range can be reset to the customer's desired values through teach calibration.

This allows calibration by using actual input.

However, executing initialization, the values return to the factory default setting and set values are discarded.

Operation

- 1) Press SC button for 3 seconds to shift to scaling setting mode and set desired input range.
- 2) At the setting of "input scaling value zero", press SF button to indicate current value.
- 3) Press UP button to display the current value of the actual input. Then the 40DV1 starts teach calibration for 0%. Polarity indicator turns ON while teach calibration.
- 4) Input 0% input signal corresponding to input range.
- 5) Press UP button to end teach calibration for 0% and shifts to parameter setting.
- 6) Press DI button to shift to "input scaling value span" .
- 7) Press SF button to indicate current value.
- 8) Press UP button to display the current value of the actual input. Then the 40DV1 starts teach calibration for 100%. Polarity indicator turns ON while teach calibration.
- 9) Input 100% input signal corresponding to input range.
- 10) Press UP button to end teach calibration for 0% and shifts to parameter setting.

■ DISPLAY SETTING MODE

PARAMETER	SETTING PARAMETER	DISPLAY	DESCRIPTION	DEFAULT SETTING
Moving average	Ave	OFF	No moving average	OFF
		A 2	Moving average with 2 samples	
		A 4	Moving average with 4 samples	
		A 8	Moving average with 8 samples	
		A 16	Moving average with 16 samples	
Brightness	brt	[0	Brightness 0 (dark)	[5
		[1	Brightness 1	
		[2	Brightness 2	
		[3	Brightness 3	
		[4	Brightness 4	
		[5	Brightness 5 (bright)	
Initialization	rst	OFF	No initialization	OFF
		rst	Execute initialization (returns to factory default setting)*1	
Version indication	-	-	Indicates firmware version (not configurable)	-

*1. While indicating "rst" and press DI or SCbutton to execute initialization.

By executing initialization, each parameter currently set is discarded and returns to default value.

EXTERNAL DIMENSIONS & TERMINAL ASSIGNMENTS unit: mm [inch]

■ TOP VIEW

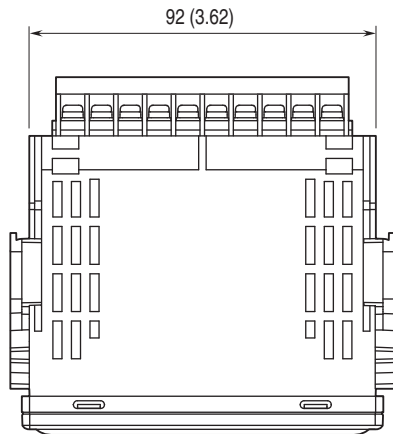

■ FRONT VIEW

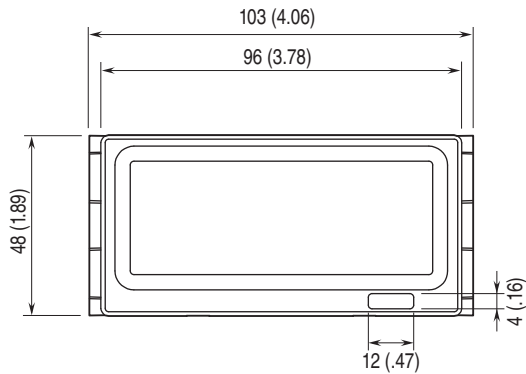

■ SIDE VIEW

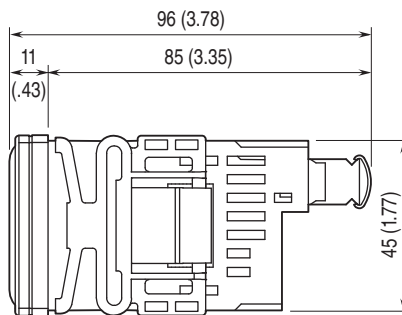

■ REAR VIEW

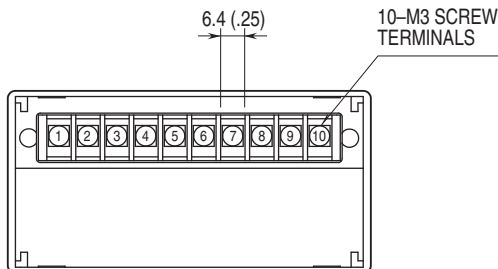

MOUNTING REQUIREMENTS unit: mm

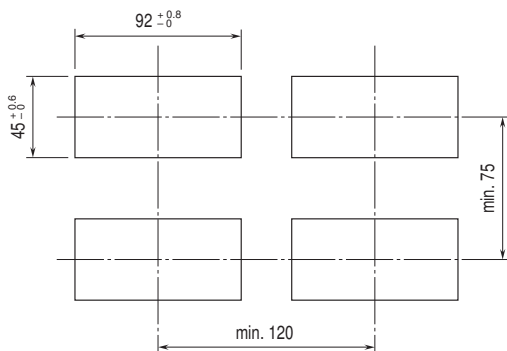

Panel thickness: 1.6 to 8.0 mm

SCHEMATIC CIRCUITRY & CONNECTION DIAGRAM

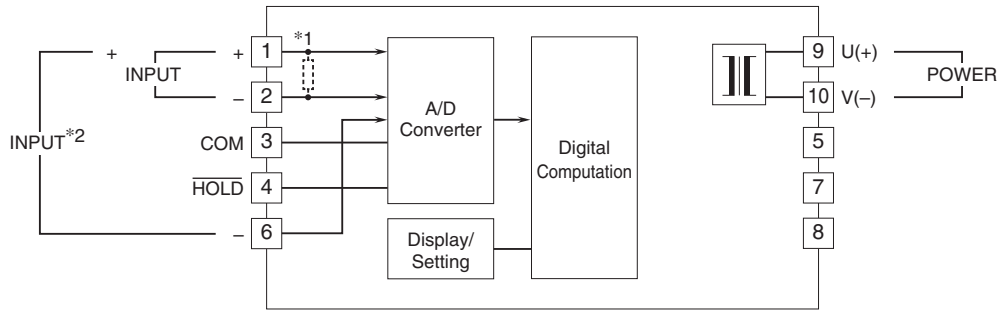

*1. Input shunt resistor attached for current input.

*2. Use in the ranges of A4 (± 199.9 mA DC), V4 (± 199.9 V DC), V5 (± 600 V DC)



Specifications are subject to change without notice.