

Digital Panel Meters 47 Series

2: SPDT relay contact, 2 points

AC INPUT DIGITAL PANEL METER

(4½ digit, LED display type, true RMS sensing)

Functions & Features

- 4 1/2 digit AC input digital panel meter
- 1/8 DIN size
- Moving average function to suppress the display flickering
- Max. and Min. value display
- IP66 front panel
- Separable terminal block
- Rear terminal cover for safety strapped to the meter

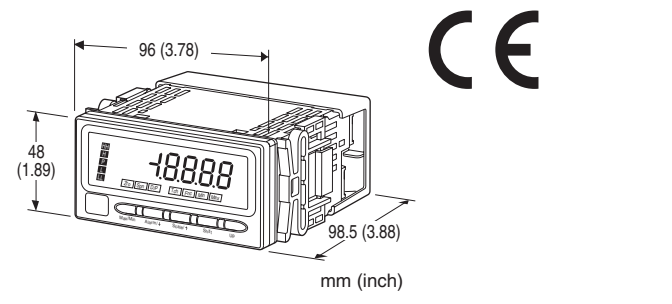

MODEL: 47LAC-[1][2][3][4]-[5][6]

ORDERING INFORMATION

- Code number: 47LAC-[1][2][3][4]-[5][6]
- Specify a code from below for each of [1] through [6].
(e.g. 47LAC-101G-M2/Q)
- Specify the specification for option code /Q
(e.g. /C01/S01/SET)

[1] INPUT

- 1: AC current
- 2: AC voltage

[2] DC OUTPUT

- 0: Without
- Current
- A: 4 - 20 mA DC (Load resistance 550 Ω max.)
- D: 0 - 20 mA DC (Load resistance 550 Ω max.)
- Voltage
- 4: 0 - 10 V DC (Load resistance 10 kΩ min.)
- 5: 0 - 5 V DC (Load resistance 5000 Ω min.)
- 6: 1 - 5 V DC (Load resistance 5000 Ω min.)
- 4W: -10 - +10 V DC (Load resistance 10 kΩ min.)

[3] ALARM OUTPUT

- 0: None
- 1: N.O. relay contact, 4 points

[4] DISPLAY COLOR

- R: Red
- YR: Orange
- G: Green
- BG: Bluegreen
- B: Blue
- W: White

[5] POWER INPUT

- AC Power
- M2: 100 - 240 V AC (Operational voltage range 85 - 264 V, 50/60 Hz)
- DC Power
- R: 24 V DC
(Operational voltage range 24 V ±10 %, ripple 10 %p-p max.)
- P: 110 V DC
(Operational voltage range 85 - 150 V, ripple 10 %p-p max.)

[6] OPTIONS

- blank: none
- /Q: With options (specify the specification)

SPECIFICATIONS OF OPTION: Q (multiple selections)

- COATING (For the detail, refer to our web site.)
- Moving parts and indicators are not coated.
- /C01: Silicone coating
- /C02: Polyurethane coating
- /C03: Rubber coating
- TERMINAL SCREW MATERIAL
- /S01: Stainless steel
- EX-FACTORY SETTING
- /SET: Preset according to the Ordering Information Sheet
(No. ESU-9511)

GENERAL SPECIFICATIONS

- Construction:** Panel flush mounting
- Degree of protection:** IP66; applicable to the front of the panel meter mounted according to the specified panel cutout
- Connection:** M3 separable screw terminal (torque 0.6 N·m)
- Screw terminal:** Nickel-plated steel (standard) or stainless steel
- Housing material:** Flame-resistant resin (gray)
- Isolation:** Input to DC output to HH output or H output to L output or LL output to power
- Input waveform**
- RMS sensing:** Up to 15 % of 3rd harmonic content
- Setting:** (Front button)
 - Scaled range

- Input type
- Alarm setpoint
- Hysteresis (deadband)
- Moving average
- Others

(Refer to the instruction manual for details)

Read rate: 40 times/sec. (25 msec.)

Averaging: None or moving average

Lockout setting: Prohibiting certain operations; protecting settings

DISPLAY

Display: 16 mm (.63) high, 4 ½ digits, 7-segment LED

Display range: -19999 to 19999

Decimal point position: 10⁻¹, 10⁻², 10⁻³, 10⁻⁴ or none

Zero indication: Higher-digit zeros are suppressed.

Over-range indication: '19999' or '19999' blinking for display values out of the scaled range.

'S.ERR' and 'Max' blinking when the input signal is out of the usable range.

Alarm status indication

LL indicator: Green turns on when the LL alarm is tripped.

L indicator: Green turns on when the L alarm is tripped.

H indicator: Red turns on when the H alarm is tripped.

HH indicator: Red turns on when the HH alarm is tripped.

P indicator: Amber turns on when none of the other alarms is tripped.

Note: Only 'P' turns on with no-alarm-output type. 'LL' or 'HH' does not turn on with dual-alarm-output type.

All setpoints can be independently set either for Hi or Lo alarm trip.

Function indicators:

Zro, Spn, D/P, Tch, Fnc, Min, Max

Display mode status and operation status, amber ON or blink

Engineering unit indication:

DC, AC, mV, V, kV, μA, mA, A, kA, mW, W,

kW, var, kvar, Mvar, VA, Hz, Ω, kΩ, MΩ,

cm, mm, m, m/sec, mm/min, cm/min, m/min,

m/h, m/s², inch, l, l/s, l/min, l/h, m³, m³/sec,

m³/min, m³/h, Nm³/h, N·m, N/m², g, kg, kg/h,

N, kN, Pa, kPa, MPa, t, t/h, °C, °F, %RH, J,

kJ, MJ, rpm, sec, min, min⁻¹, pH, %, ppm, etc.

INPUT SPECIFICATIONS

Frequency: 40 Hz - 1 kHz

Overload capacity: 200 % of the selected measuring range

Default value

AC current input: Measuring range 0 - 200 mA

AC voltage input: Measuring range 0 - 10 V

INPUT CODE: 1

TYPE IND	MEASURING RANGE	OPERATIONAL RANGE	INPUT IMPEDANCE
A2	0 - 2 mA	0 - 2.2 mA	100 Ω
A20	0 - 20 mA	0 - 22 mA	1 Ω
A200	0 - 200 mA	0 - 220 mA	1 Ω

INPUT CODE: 2

TYPE IND	MEASURING RANGE	OPERATIONAL RANGE	INPUT IMPEDANCE
V0.1	0 - 0.1 V	0 - 0.11 V	≥ 100 kΩ
V1	0 - 1 V	0 - 1.1 V	≥ 100 kΩ
V10	0 - 10 V	0 - 11 V	≥ 1 MΩ

OUTPUT SPECIFICATIONS

DC Output

- DC Current

Operational range: -5 - +105 %

- DC Voltage

Operational range: -5 - +105 %

Alarm Output: Relay contact

Rated load: 250 V AC @ 3 A (cos φ = 1)

30 V DC @ 3 A (resistive load)

Maximum switching voltage: 250 V AC, 30 V DC

Maximum switching power: 750 VA, 90 W (resistive load)

Minimum load: 5 V DC @ 10 mA

Mechanical life: ≥ 5 × 10⁶ cycles (rate 180 cycles/min.)

INSTALLATION

Power consumption

- AC: Approx. 6.5VA

- DC: Approx. 3 W

Operating temperature: -10 to +55°C (14 to 131°F)

Operating humidity: 30 to 90 %RH (non-condensing)

Mounting: Panel flush mounting

Weight: 300 g (0.66 lb)

PERFORMANCE in percentage of max. span

Accuracy

Display: ±0.5 % ±20 digits (input 5 - 100 %)

Output: ±0.1 % (DC output = display + output)

Temp. coefficient: ±0.05 %/°C (±0.03 %/°F)

Input resolution: Max. 16 bits

Output resolution: Max. 14 bits

Response time: ≤ 0.5 sec.

(alarm output: 0 - 100 % at 90 % setpoint)

≤ 0.5 sec. (DC output: 0 - 90 %)

Line voltage effect: ±0.1 % over voltage range

Insulation resistance: ≥ 100 MΩ with 500 V DC

Dielectric strength: 2000 V AC @ 1 minute (input to DC output to HH output or H output to L output or LL output to power to ground)

STANDARDS & APPROVALS

EU conformity:

EMC Directive

EMI EN 61000-6-4

EMS EN 61000-6-2

Low Voltage Directive

EN 61010-1

Measurement Category II (alarm output)

Installation Category II (power)

Pollution degree 2

Input or DC output to alarm output to power: Reinforced insulation (300 V)

Input to DC output: Basic insulation (300 V)

RoHS Directive

Protection against access to the terminal blocks:

Finger protection (VDE 0660-514)

EXTERNAL VIEW

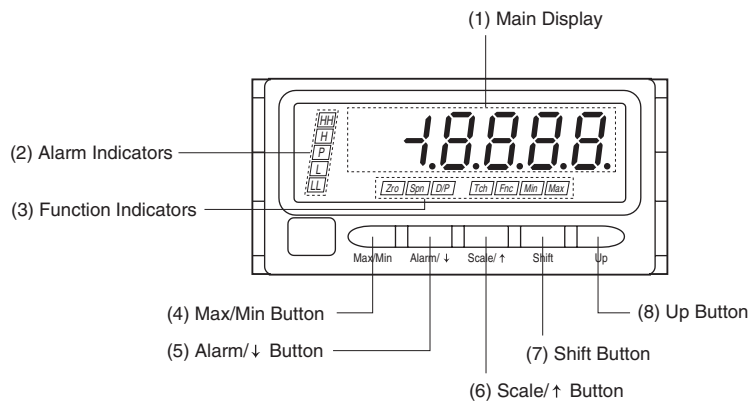

• COMPONENT IDENTIFICATION

No.	COMPONENT	FUNCTION
(1)	Main display	Indicates present values, setting values and status of the unit.
(2)	Alarm indicators	Indicate alarm status of the input signal.
(3)	Function indicators	Indicate the status in each setting mode.
(4)	Max/Min button	Used to switch the main display to show the present values, maximum values or minimum values etc.
(5)	Alarm/↓ button	Used to confirm alarm setting value and to move on to the alarm and other setting modes; or to shift through setting items in each setting mode.
(6)	Scale/↑ button	Used to move on to the scaling and other setting modes; or to shift through setting items in each setting mode.
(7)	Shift button	Used to move on to the setting standby status of each setting mode and shift through display digits in each setting mode.
(8)	Up button	Used to execute/cancel Forced Zero or to select setting values in each setting mode.

Note: Refer to the operating manual for details on each function.

EXTERNAL DIMENSIONS & TERMINAL ASSIGNMENTS unit: mm [inch]

■ TOP VIEW

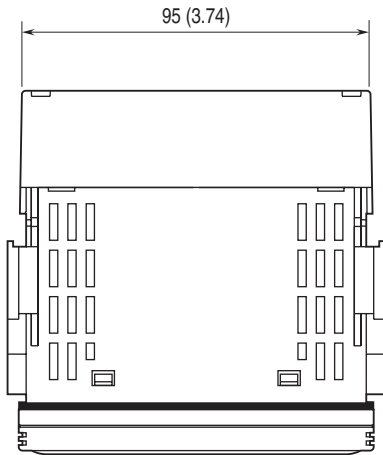

■ FRONT VIEW

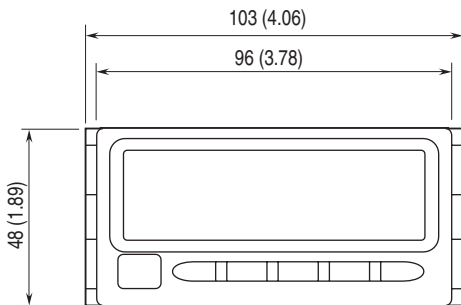

■ SIDE VIEW

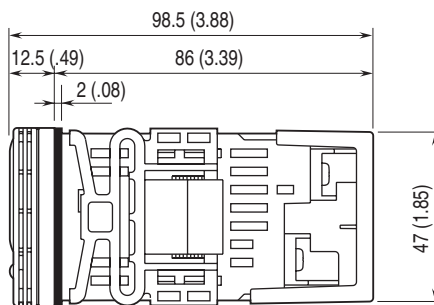

■ REAR VIEW

• No Alarm Output

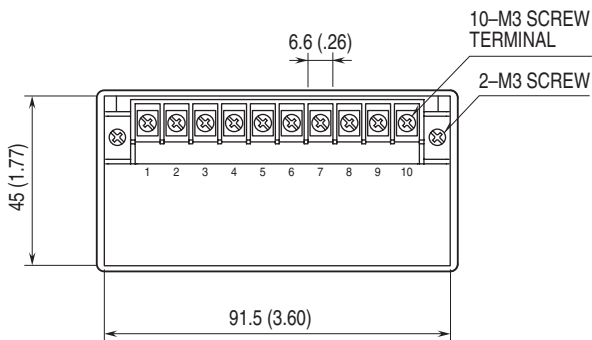

• Alarm Output

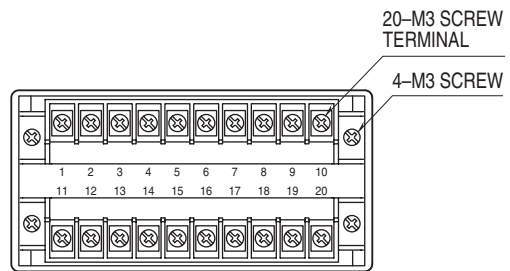

MOUNTING REQUIREMENTS unit: mm

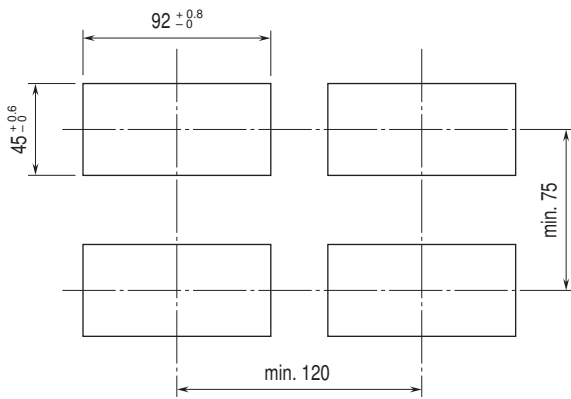

Panel thickness: 1.6 to 8.0 mm

SCHEMATIC CIRCUITRY & CONNECTION DIAGRAM

■ ALARM OUTPUT CODE 0: No alarm output

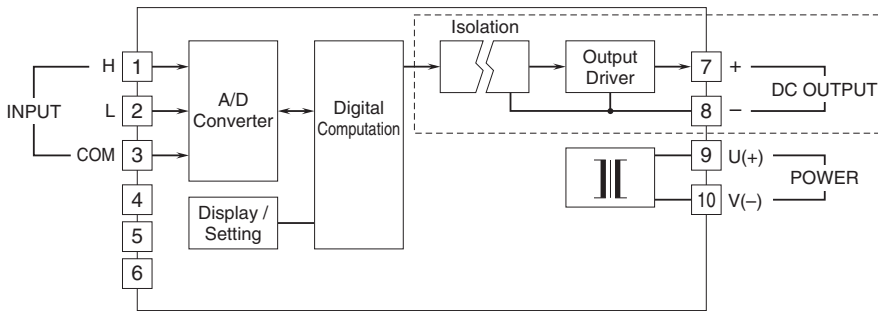

■ ALARM OUTPUT CODE 1: N.O. contact, 4 points

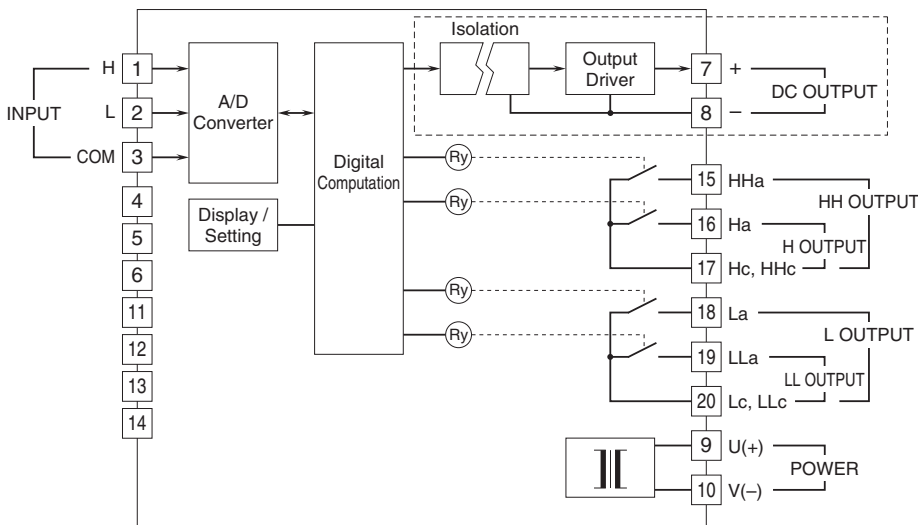

■ ALARM OUTPUT CODE 2: SPDT contact, 2 points

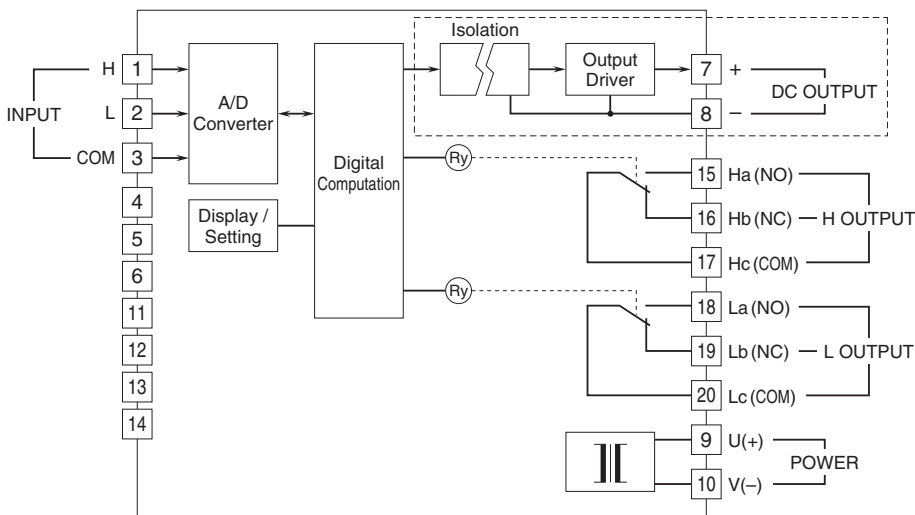

Note: The section enclosed by broken line is only with DC output option.

■ Relay Protection
• AC Powered

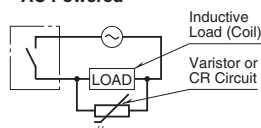

• DC Powered

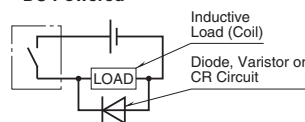

• Input Terminal Assignments

INPUT TYPE (indicator)	MEASURING RANGE	INPUT TERMINALS
A2	0 – 2mA	②-③
A20 A200	0 – 20mA 0 – 200mA	①-③
V0.1 V1	0 – 0.1V 0 – 1V	②-③
V10	0 – 10V	①-③



Specifications are subject to change without notice.