

Field Network Modules 61-UNIT Series

ANALOG I/O MODULE

(DeviceNet)

Functions & Features

- Interfacing analog I/O signals from/to Mini-M, Pico-M and other signal conditioner modules with DeviceNet
- Saving power and I/O wiring inside an instrumentation panel

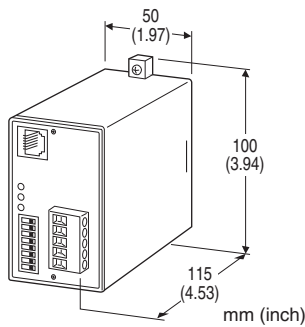

MODEL: 61D-[1][2]-[3][4]

ORDERING INFORMATION

- Code number: 61D-[1][2]-[3][4]
- Specify a code from below for each of [1] through [4].
(e.g. 61D-161-K/Q)
- Specify the specification for option code /Q
(e.g. /C01)

[1] NO. OF CHANNELS

- 04: 4 points
- 08: 8 points
- 16: 16 points

[2] I/O TYPE

- 1: Input
- 2: Output

[3] POWER INPUT

- AC Power
- K: 85 - 132 V AC
(Operational voltage range 85 - 132 V, 47 - 66 Hz)
(CE not available)
- DC Power
- R: 24 V DC
(Operational voltage range 24 V \pm 10 %, ripple 10 %p-p max.)
(Specify power suffix code R (24 V DC) when the UNIT is to be combined with the M8BS2.)

[4] OPTIONS

- blank: none
- /Q: With options (specify the specification)

SPECIFICATIONS OF OPTION: Q

- COATING (For the detail, refer to our web site.)
- /C01: Silicone coating
- /C02: Polyurethane coating
- /C03: Rubber coating

RELATED PRODUCTS

- Installation Base (model: M2BS2)
- Installation Base (model: M8BS2)
- Programming Unit (model: PU-2x)

GENERAL SPECIFICATIONS

Construction: Plug-in

Connection

- DeviceNet:** Euro type connector terminal (applicable wire size: 0.2 to 2.5 mm², stripped length 7 mm)
- I/O:** Via the Installation Base (model: MxB52)
- Power input:** Via the Installation Base (model: MxB52)
- Housing material:** Flame-resistant resin (black)
- Isolation:** I/O to DeviceNet to power
- Power indicator:** Green LED turns on with power supplied.

DeviceNet COMMUNICATION

- Transmission cable:** Approved for DeviceNet
- Node address setting:** DIP switch; 00 - 63
- Baud rate setting:** DIP switch
- MS (Module Status) indicator:** Bi-color (green/red) LED indicates device status.
- NS (Network Status) indicator:** Bi-color (green/red) LED indicates status of the communication link.

INPUT SPECIFICATIONS

- Analog Input
- Input range:** 1 - 5 V DC
- Input resistance:** \geq 1 M Ω
- (Each input must be isolated by signal conditioners. Non-isolated modules such as M2BW and M8BW are not usable.)
- A/D conversion**
- Moving averaging:** 4 samples
- Sampling rate:** 160 ms
- A/D conversion output:** 16-bit binary
- Signal range 0 - 100 % is converted into hexadecimal 0000 - 1770 (0 - 6000). -15 to 0 % is represented by 2's complements.
- Overall range is represented by hexadecimal FC7C - 1AF4 (-900 - +6900), for -15 - +115 %.

Note: In the firmware version 3.00 or later, analog input range 0 - 100% can be converted into hexadecimal 0000 - 2710 (0 - 10000).

In addition, negative values of analog input range -15 to 0% can be converted into signed absolute values.

Refer to the instruction manual for details.

STANDARDS & APPROVALS

EU conformity:

EMC Directive

EMI EN 61000-6-4

EMS EN 61000-6-2

RoHS Directive

OUTPUT SPECIFICATIONS

■ Analog Output

Output range: 1 - 5 V DC

Load resistance: 20 kΩ minimum

(Output must be isolated with signal conditioners.

When the transmission line is open, the last value sampled before failure is held. Non-isolated modules such as M2BW and M8BW are not usable.)

D/A conversion output: 16-bit binary

Signal range 0 - 100 % is converted into hexadecimal 0000 - 1770 (0 - 6000). -15 to 0 % is represented by 2's complements.

Overall range is represented by hexadecimal FC7C - 1AF4 (-900 - +6900), for -15 - +115 %.

Note: In the firmware version 3.00 or later, analog output range 0 - 100% can be converted into hexadecimal 0000 - 2710 (0 - 10000).

In addition, negative values of analog output range -15 to 0% can be converted into signed absolute values.

Refer to the instruction manual for details.

INSTALLATION

Power consumption

•AC: Approx. 4 VA

•DC: Approx. 4 W (160 mA)

Supply voltage to network: 11 - 25 V DC supplied through the network terminal block

Supply current to network: 60 mA max. @ 24 V

Operating temperature: -5 to +55°C (23 to 131°F)

Operating humidity: 30 to 90 %RH (non-condensing)

Atmosphere: No corrosive gas or heavy dust

Mounting: Installation Base (model: MxBS2)

Weight: 250 g (0.55 lb)

PERFORMANCE in percentage of span

A/D conversion: ±0.1 %

D/A conversion: ±0.1 %

Temp. coefficient: ±0.015 %/°C (±0.008 %/°F)

Permissible power failure duration: ≤ 10 msec.

Insulation resistance: ≥ 100 MΩ with 500 V DC

Dielectric strength: 1500 V AC @ 1 minute

(I/O to DeviceNet to power)

EXTERNAL VIEW

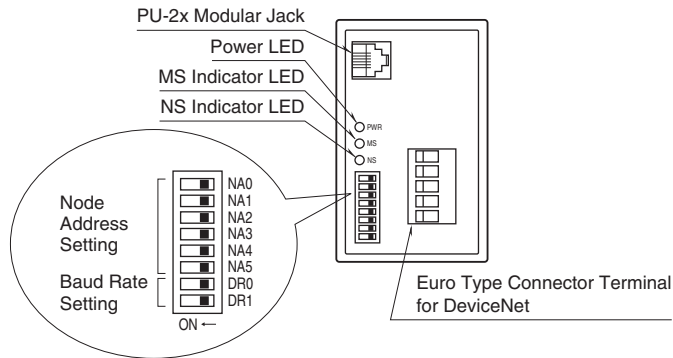

EXTERNAL DIMENSIONS unit: mm [inch]

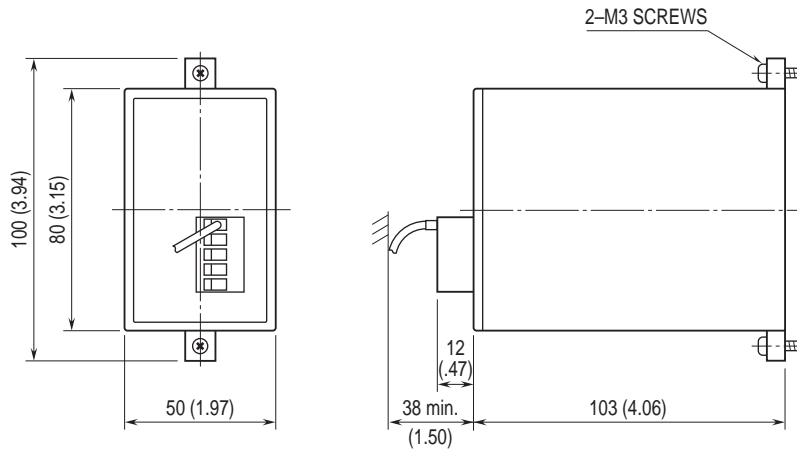

SCHEMATIC CIRCUITRY & CONNECTION DIAGRAM

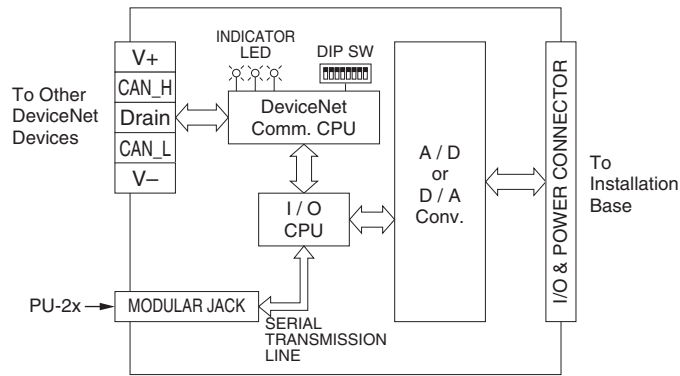

■ CABLE IDENTIFICATION

The following table defines wire insulation colors and designations. The terminal block is labeled also in the same colors so that the correct assignment can be confirmed.

COLOR	DESIG.	DESCRIPTION
black	V -	Power (-)
blue	CAN_L	Signal Low
bare	Drain	Shield
white	CAN_H	Signal High
red	V +	Power (+)



Specifications are subject to change without notice.