

Paperless Recording System

PAPERLESS RECORDER

(color LCD display)

Functions & Features

- 96 mm square size
- Records, displays and sets alarms for 8 analog and 8 contact inputs and 8 contact outputs
- Maps the remote I/O data to logical channels
- Built-in I/O: 2 analog, 3 universal and 2 contact inputs and 2 contact outputs
- Trigger function: Records only necessary part of the data
- Recorded data can be transferred to a PC with memory cards or COP-US and converted to CSV format with 71VRCFG
- TFT color LCD
- IP65 front panel
- Separable two pieces terminal block
- Safety terminal cover tethered to the device with a strap

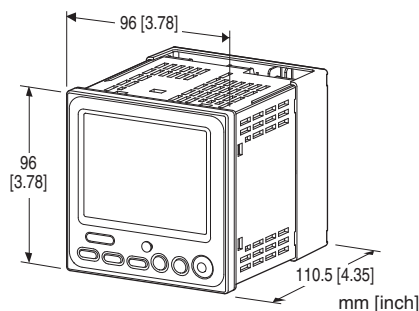

MODEL: 71VR1-[1][2]1-[3][4]

ORDERING INFORMATION

- Code number: 71VR1-[1][2]1-[3][4]
- Specify a code from below for each of [1] through [4].
(e.g. 71VR1-N101-M2/1/Q)
- Specify the specification for option code /Q
(e.g. /C01)

[1] LANGUAGE

N: Japanese

E: English

(Language (Japanese or English) can be chosen by front panel setting.)

[2] ANALOG INPUT

00: None

10: DC input, 2-points

50: DC input, 2-points,

Universal input, 3-points (V, mA, T/C, RTD)

EXTERNAL INTERFACE

1: Modbus

[3] POWER INPUT

AC Power

M2: 100 - 240 V AC (Operational voltage range 85 - 264 V, 50/60 Hz)

DC Power

R: 24 V DC

(Operational voltage range 24 V \pm 10 %, ripple 10 %p-p max.)

P: 110 V DC

(Operational voltage range 85 - 150 V, ripple 10 %p-p max.)

[4] OPTIONS (multiple selections)

Configurator Interface

blank: Infrared (Discontinued, select /1)

/1: Stereo jack

Other Options

blank: none

/Q: Option other than the above (specify the specification)

SPECIFICATIONS OF OPTION: Q

COATING (For the detail, refer to our web site.)

/C01: Silicone coating

/C02: Polyurethane coating

/C03: Rubber coating

RELATED PRODUCTS

- Precision Resistor Module (model: REM2-50)

Use for mA universal input

- PC Configurator cable (model: COP-US)

- PC configurator software (model: 71VRCFG)

Downloadable at our web site.

- Remote I/O R3 series

Modbus interface module (model: R3-NM1)

- Remote I/O R5 series

Modbus interface module (model: R5-NM1)

- Modbus I/O module (model: R7M)

R7 Configurator Software (Model: R7CON)

Modbus communication parameters of the R7M must be configured by using R7CON and the dedicated cable.

- Devices equipped with Modbus communication. For detailed information, visit our web site.

- Memory card

A memory card is required to store data in the unit.

Use the specified model number of memory card.

Available for purchase from us. Consult us.

- Hagiwara Solutions NSD6-004GH(B21SEI)

(NSD6-004GH(A00SDI, NSD6-002GT, NSDA-004GT and NSDA-004GL ... discontinued)
 - Apacer Technology AP-ISD04GIS4B-3T
 (AP-ISD04GIS4B-T ... discontinued)

PACKAGE INCLUDES...

- Mounting bracket: 1 pair
- CJC sensor (for 71VR1-x501-x): 3
- Plug conversion adapter: 1

Used to match the size of the jack on the unit and the PC configurator cable.

GENERAL SPECIFICATIONS

Construction: 96-mm square (1/4 DIN size) panel flush mounted

Degree of protection: IP65; applicable to the front panel of the recorder with single mounting according to the specified panel cutout

Connection: M3 separable screw terminal (torque 0.5 N·m)

Screw terminal: Nickel-plated steel

Housing material: Flame-resistant resin (black)

Isolation: Analog input each other to contact input to contact output 1 to contact output 2 to Modbus interface to power to FE (Functional Earth)

Number of assignable logical channels

Analog input: 8 points max.

Contact input: 8 points max.

Contact output: 8 points max.

Data storage: Stores Trend and Alarm history in memory card.

Trend: Stored in files named time and date.

60000 samples in one file

Storage capacity: 200 files max.

Storage time:

Approx. 13 days at storing rate 0.1 sec.,

approx. 138 days at 1 sec.,

approx. 1388 days at 10 sec.,

approx. 8333 days at 1min.,

approx. 250000 days at 30 min.,

approx. 500000 days at 1 hour.

Alarm history: Stored in alarm history file, 200 items max.

■ DISPLAY

Display device: 3.5-inch TFT LCD

Display colors: 256

Resolution: 320 × 240 pixels

Backlight: LED

Display update interval: 500 msec.

Sample rate:

NUMBER OF MODBUS LOGICAL CHANNELS	SAMPLE RATE (sec.)								
	0.1	0.2	0.5	1	2	5	10	20	30
0	Y*	Y*	Y	Y	Y	Y	Y	Y	Y
1 to 2	---	Y*	Y	Y	Y	Y	Y	Y	Y
3 to 5	---	---	Y	Y	Y	Y	Y	Y	Y
6 to 10	---	---	---	Y	Y	Y	Y	Y	Y
11 to 20	---	---	---	---	Y	Y	Y	Y	Y
21 to 24	---	---	---	---	---	Y	Y	Y	Y

NUMBER OF MODBUS LOGICAL CHANNELS	SAMPLE RATE (min.)					SAMPLE RATE (hour)
	1	5	10	20	30	1
0	Y	Y	Y	Y	Y	Y
1 to 2	Y	Y	Y	Y	Y	Y
3 to 5	Y	Y	Y	Y	Y	Y
6 to 10	Y	Y	Y	Y	Y	Y
11 to 20	Y	Y	Y	Y	Y	Y
21 to 24	Y	Y	Y	Y	Y	Y

[Legend] Y: Selectable, ---: Not selectable

*Selectable when without thermal input settings

20 sec. or longer sampling rate is available with firmware of major version 1, minor version 4.01 or higher.

INPUT SPECIFICATIONS

■ Universal Input (Ai3, Ai4, Ai5)

• DC current input

(Range: Input resistance)

-20 - +20 mA: 50 Ω (separately provided REM2)

• DC voltage input

(Range: Input resistance)

-1 - +1 V: ≥ 1 MΩ

-5 - +5 V: ≥ 1 MΩ

-10 - +10 V: ≥ 1 MΩ

• **Thermocouple input:** K, E, J, T, B, R, S, C, N, U, L, P, PR
 (See Table 1.)

Input resistance: ≥ 30 kΩ

Burnout sensing: ≤ 0.1 μA

Burnout indication: Maximum value (upscale burnout) of the usable range

• **RTD input:** Pt 100 (JIS '97, IEC), Pt 100 (JIS '89), JPt 100 (JIS '89), Pt 50Ω (JIS '81), Ni 100, Cu 10, Cu 50 (See Table 2.)

Input resistance: ≥ 1 MΩ

Maximum leadwire resistance: 100 Ω per wire

Burnout indication: Maximum value (upscale burnout) of the usable range

Sensing current: ≤ 1 mA

■ DC Current Input (Ai1, Ai2)

(Range: Input resistance)

-20 - +20 mA: 100 Ω (incorporated)

■ DC Voltage Input (Ai1, Ai2)

(Range: Input resistance)

-1 - +1V: ≥ 1MΩ

-5 - +5V: ≥ 1MΩ

-10 - +10V: ≥ 1MΩ

■ **Contact Input (Di1, Di2):** Dry contact, 2 points

Input resistance: Approx. 1.8 kΩ

Common: Negative

Sensing: 12 V DC

ON current/resistance: ≥ 1.5 mA, ≤ 1.5 kΩ

OFF current/resistance: ≤ 0.75 mA, ≥ 15 kΩ

[Table 1 (Thermocouple input)]

T/C	USABLE RANGE (°C)	CONFORMANCE RANGE (°C)
K (CA)	-272 to +1472	-150 to +1370
E (CRC)	-272 to +1100	-170 to +1000
J (IC)	-260 to +1300	-180 to +1200
T (CC)	-272 to +500	-170 to +400
B (RH)	24 to 1920	1000 to 1760
R	-100 to +1860	380 to 1760
S	-100 to +1860	400 to 1760
C (WRe 5-26)	-52 to +2416	100 to 2315
N	-272 to +1400	-130 to +1300
U	-252 to +700	-200 to +600
L	-252 to +1000	-200 to +900
P (Platinel II)	-52 to +1496	0 to 1395
(PR)	-52 to +1860	300 to 1760

Overrange input (out of the usable range) is handled as burnout.

[Table 2 (RTD input)]

RTD	USABLE RANGE (°C)	CONFORMANCE RANGE (°C)
Pt 100 (JIS '97, IEC)	-240 to +900	-200 to +850
Pt 100 (JIS '89)	-240 to +900	-200 to +660
JPt 100 (JIS '89)	-236 to +560	-200 to +510
Pt 50 (JIS '81)	-236 to +700	-200 to +649
Ni 100	-100 to +252	-80 to +250
Cu 10 @25°C	-212 to +312	-50 to +250
Cu 50	-100 to +200	-50 to +150

Overrange input (out of the usable range) is handled as burnout.

OUTPUT SPECIFICATIONS

■ Network Interface

• **Modbus-RTU:** Retrievable analog data is Int data (signed 16 bits) only.

Transmission: Half-duplex, asynchronous, no procedure

Interface: Conforms to TIA/EIA-485-A

Max. transmission distance: 500 meters

Baud rate: 4800, 9600, 19200, 38400 bps

Data bit: 8 bits

Parity: Odd

Stop bit: 1 bit

Max. number of nodes: 15 (except the master)

Media: Shielded twisted-pair cable (CPEV-S 0.9 dia.)

■ Contact Output (Do1, Do2)

• **Relay Output**

Relay rating:

250 V AC @5 A (cos φ = 1)

30 V DC @5 A (resistive load)

Maximum switching voltage: 250 V AC or 30 V DC

Maximum switching power: 1250 VA or 150 W

Minimum load: 5 V DC @10 mA

Mechanical life: 2 × 10⁷ cycles

INSTALLATION

Power consumption

• **AC:**

Approx. 7 VA at 100 V

Approx. 10 VA at 240 V

• **DC:** Approx. 6 W

Operating temperature: -5 to +55°C (23 to 131°F)

Operating humidity: 30 to 90 %RH (non-condensing)

Atmosphere: No corrosive gas or heavy dust

Mounting: Panel flush mounting

Weight: 550 g (1.21 lb)

PERFORMANCE

Conversion accuracy

DC input: ±0.1% ±1 digit

Thermocouple input: ±1°C (±2°C for B, R, S, C, PR)

RTD input: ±1°C (±3°C for Cu 10)

CJC error: ±2°C max. at 25°C ±10°C

±4°C max. for R, S, PR

Temp. coefficient: ±0.015 %/°C (±0.008 %/°F)

(±0.05 %/°C (±0.03 %/°F) for Cu 10) of max. span

Response time: ≤ 0.5 sec. for DC input with the sample rate set to 100 msec.

≤ 2.5 sec. for T/C, RTD input with the sample rate set to 500 msec.

Response time of alarm output, 0 - 100 % at 90 % setpoint.

Line voltage effect: ±0.1 % over voltage range

Calendar clock accuracy: Monthly deviation 2 minutes at 25°C

Battery backup: Approx. one month

Insulation resistance: ≥ 100 MΩ with 500 V DC

Dielectric strength: 2000 V AC @1 minute

(analog input each other to contact input to contact output 1 to contact output 2 to Modbus interface to power to FE)

STANDARDS & APPROVALS

EU conformity:

EMC Directive

EMI EN 61000-6-4

EMS EN 61000-6-2

Low Voltage Directive

EN 61010-1

Measurement Category II (contact output)

Installation Category II (power)

Pollution degree 2

Analog input or contact input or contact output or network interface to power to FE: Reinforced insulation (300 V)

Analog input each other or contact input or network interface to contact output each other:

Basic insulation (300 V)
 RoHS Directive
Protection against access to the terminal blocks:
 Finger protection (VDE 0660-514)

EXTERNAL VIEW

FRONT VIEW

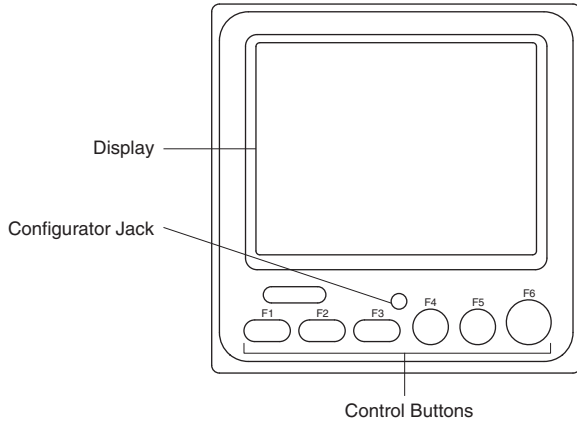

REAR VIEW

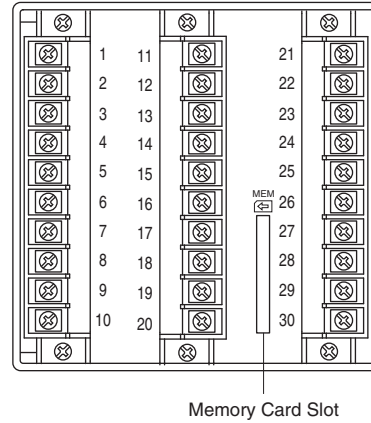

The terminals for number 11 through 20 are only with 5-points input.

COMMUNICATION CABLE CONNECTIONS

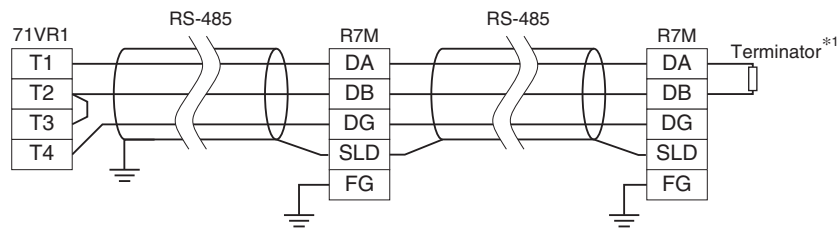

*1. Use a terminating resistor when the device is at the extreme end of a transmission line.

EXTERNAL DIMENSIONS & TERMINAL ASSIGNMENTS unit: mm [inch]

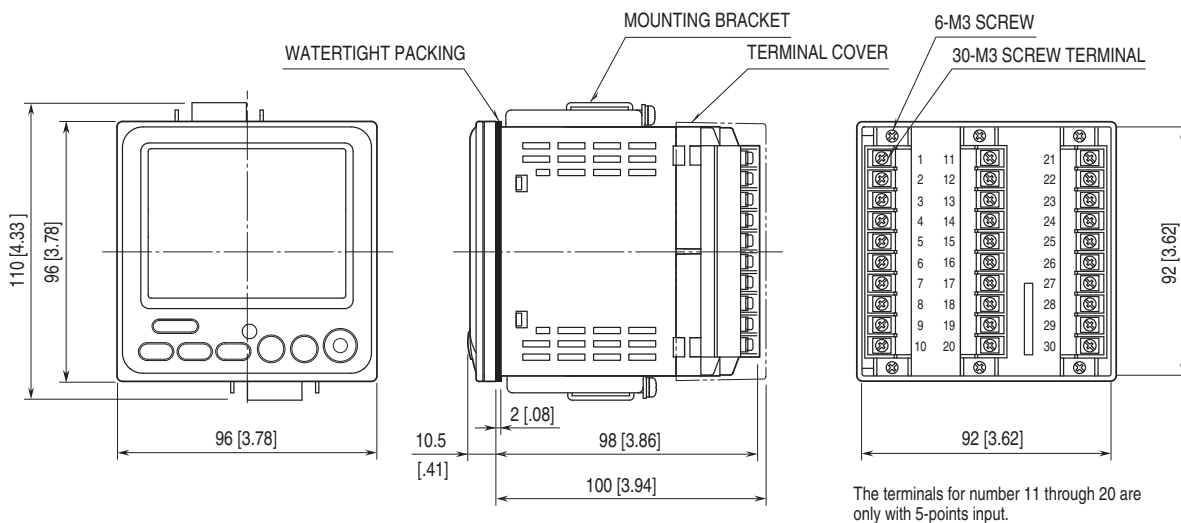

The terminals for number 11 through 20 are only with 5-points input.

MOUNTING REQUIREMENTS unit: mm [inch]

■ PANEL CUTOUT

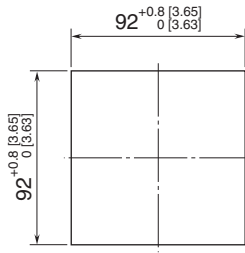

Usable panel thickness: 0.5 – 10 mm [0.02 to 0.39 inch]

SCHEMATIC CIRCUITRY & CONNECTION DIAGRAM

Note: In order to improve EMC performance, bond the FE terminal to ground.

Caution: FE terminal is NOT a protective conductor terminal.

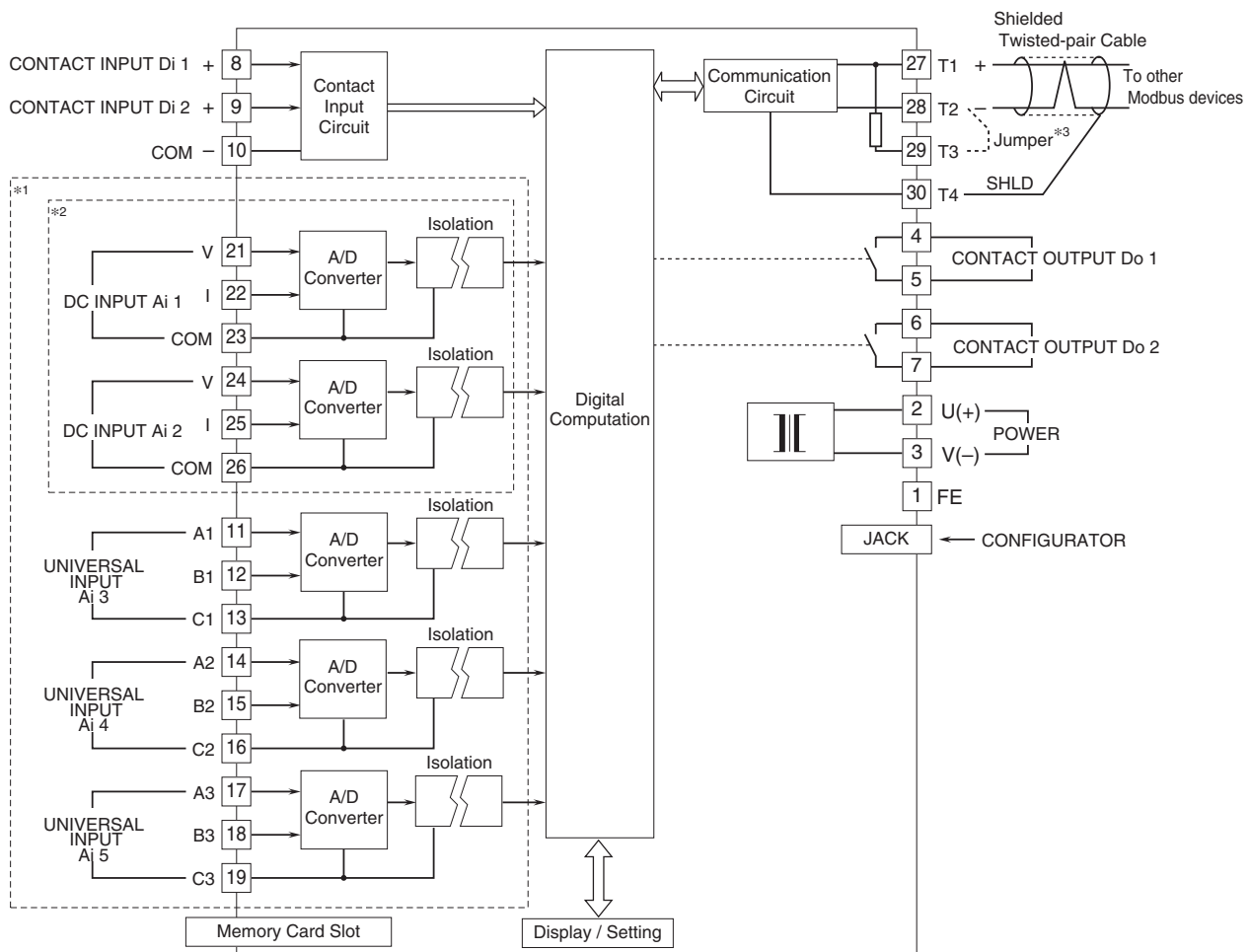

*1. Only with 5-point inputs

*2. Only with 2-point DC inputs

*3. When the device is located at the end of a transmission line via twisted-pair cable (when there is no cross-wiring), close across the terminals T2 - T3 with a leadwire.

Input Connection e.g.

• DC Input

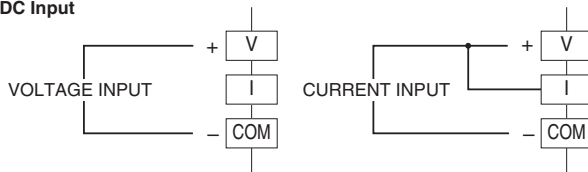

Note: Short across the terminals V and I for Current Input.

• Universal Input

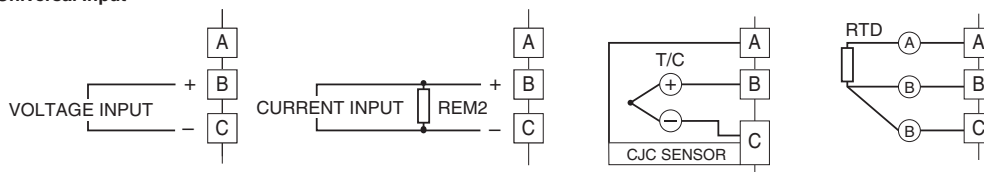

Note: For mA input, the REM2 is required.

SYSTEM CONFIGURATION EXAMPLES

Paperless Recorder (model: 71VR1)

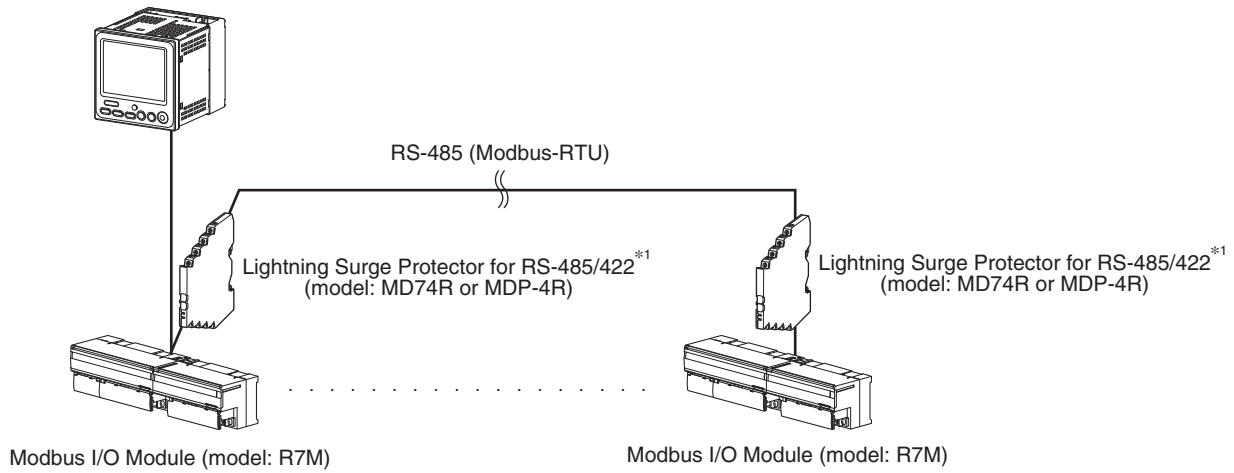

*1. Insert lightning surge protectors recommended in this example if necessary.



Specifications are subject to change without notice.