

## Paperless Recording System

### PAPERLESS RECORDER

(built-in input modules)

#### Functions & Features

- 100 msec. storing rate
- Data stored in CF Cards and SD Cards
- Memory card slot accessible at the front
- 'Quick Setup' helps you to start and program the recorder
- Real time monitor at the host PC via Ethernet
- Dedicated application software to view and analyze the data
- 5.5 inch TFT LCD display
- Touch panel operation
- IP65 front panel

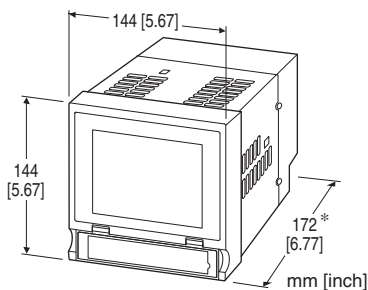

\*195 [7.68] with the 73VR2108, 73VR2110 and 73VR2112.

### MODEL: 73VR21[1]-[2]-[3][4]

#### ORDERING INFORMATION

- Code number: 73VR21[1]-[2]-[3][4]
- Specify a code from below for each of [1] through [4].  
(e.g. 73VR2102-E-M2/Q)
- Specify the specification for option code /Q  
(e.g. /C01/S01/HA)

#### [1] NO. OF CHANNELS

- 02: 2-point inputs
- 04: 4-point inputs
- 06: 6-point inputs
- 08: 8-point inputs
- 10: 10-point inputs
- 12: 12-point inputs

#### [2] LANGUAGE

- N: Japanese
- E: English

#### [3] POWER INPUT

AC Power

**M2:** 100 - 240 V AC (Operational voltage range 85 - 264 V, 47 - 66 Hz)

(CE not available for desktop type)

DC Power

**R:** 24 V DC

(Operational voltage range 24 V ±10 %, ripple 10 %p-p max.)

#### [4] OPTIONS

**blank:** none

**/Q:** With options (specify the specification)

#### SPECIFICATIONS OF OPTION: Q (multiple selections)

COATING (For the detail, refer to our web site.)

**/C01:** Silicone coating

**/C02:** Polyurethane coating

**/C03:** Rubber coating

TERMINAL SCREW MATERIAL

**/S01:** Stainless steel

INSTALLATION

**/HA:** Desktop type (with handle and feet)

(Desktop type cannot be mounted on a panel surface.

The handle and rubber feet cannot be detached.)

#### CAUTION

- With 100 msec. storing rate, measured value may be susceptible to inaccuracies due to the fast update cycle. If this is the case, please choose 500 msec. or slower rate.

#### RELATED PRODUCTS

- Resistor module (model: REM3-250)

##### ■ Memory card

A memory card is required to store data in the 73VR21x. Available for purchase from us. Consult us (except SD/CF conversion adapter).

We will not guarantee the product's described performance if a memory card other than purchased from us, or specified below, is used.

- CF Card

1. Manufacturer: Hagiwara Solutions

Model No.: MCF10P-xxxxS

Capacity: 128 MB through 1 GB

(CFI-xxxxDG ... discontinued)

2. Manufacturer: Apacer Technology

Model name: CFC III

Model No.: AP-CFxxxxRBNS-ETDNRG

Capacity: 256 MB through 1 GB

Part No.: 81.28L10.UC08B (256 MB)

81.29L10.UC08B (512 MB)

81.2AL10.UC08B (1 GB)

(AP-CFxxxxE3ER-ETNDNR, AP-CFxxxxE3ER-ETNDNRK, AP-CFxxxxE3NR-ETNDNRQ ... discontinued)

- SD Card (Compatible with 73VR21 Ver.5.03.xx or later)

Manufacturer: Hagiwara Solutions

Model No.: NSD6-004GH (B21SEI)

(NSDA-004GT, NSDA-004GL ... discontinued)

SD/CF Conversion Adapter is required to use SD card. There are some restrictions on using SD cards. For details, refer to the instruction manual.

- SD/CF Conversion Adapter (operation confirmed):

DeLOCK adaptor CF II to SDHC,SDXC

Model: 61796 (operation has been confirmed with the adaptor purchased in the year of 2016.)

62637 (operation has been confirmed with the adaptor purchased in the year of 2018.)

## PACKAGE INCLUDES...

- 73VR Application Software CD (model: 73VRPAC2)
- Mounting brackets (two)  
(/HA: Not included for desktop type)

## GENERAL SPECIFICATIONS

**Construction:** Panel mount type or desktop type

**Degree of protection:** IP65; applicable to the front panel of the recorder with single mounting according to the specified panel cutout (/HA: Desktop type cannot be mounted on a panel surface)

### ■ CONNECTION

**Ethernet:** RJ-45 Modular Jack

**Power input, signal input, trigger input, alarm output:**

M3 separable screw terminal (torque 0.5 N·m)

**Recommended solderless terminal:**

**Applicable wire size:** 0.25 to 1.65 mm<sup>2</sup> (AWG 22 to 16)

**Recommended manufacturer:** Japan Solderless Terminal MFG.Co.Ltd, Nichifu Co.,Ltd

**Screw terminal:** Nickel-plated steel (standard) or stainless steel

### ■ MATERIALS

**Enclosure:** Steel

**Bezel:** Flame-resistant resin (black)

**Front filter:** Transparent resin

**Isolation:** Input 1 to input 2 to input 3 to input 4 to input 5 to input 6 to input 7 to input 8 to input 9 to input 10 to input 11 to input 12 to trigger input to alarm output to power input to FG to Ethernet

**Burnout for T/C and RTD input:** Upscale, Downscale or No burnout selectable

Select 'No Burnout' to minimize the measuring errors caused by the sensor/wire resistance and the burnout sensing current.

With RTD input, the signal may go transiently to the opposite direction from the burnout setting.

With DC input, the burnout setting is ignored and the burnout sensing current is cancelled.

**Cold junction compensation (CJC) for T/C input:** CJC can be enabled or disabled per each channel.

CJC sensor attached to Input 1 and Input 7\* terminals.(Input 7 for the 73VR2108, 73VR2110 and 73VR2112)

**Operating mode setting:** Application software; burnout type, cold junction compensation, line noise frequency, A/D conversion mode setting available

**Line noise filter:** NMNR ratio to the line frequency and its harmonic contents can be optimized. Factory set to 50/60 Hz mode for use with both frequencies.

Select either frequency for the most effective result.

**A/D conversion mode:** Fast, Medium or Slow selectable. With Slow setting, data fluctuations are minimized with limited sampling time (speed).

With Fast setting, sampling time (speed) can be high through data fluctuations increase.

### ■ INTERFACE

**Ethernet:** 10BASE-T / 100BASE-TX automatically switched; Conforms to IEEE 802 (10BASE-T) or IEEE 802.3 (100BASE-TX)

**IP address:** 192.168.0.1 (factory default setting)

**Subnet mask:** 255.255.255.0 (factory default setting)

**Default gateway:** None (factory default setting)

**CF Card slot:** Type I; for use with the cards' operating voltage 3.3 V

**USB:** Conforms to Version 1.1

### ■ DISPLAY

**Display device:** 5.5-inch TFT LCD

**Display colors:** 256

**Resolution:** 320 × 240 pixels

**Pixel pitch:** 0.12 × 0.35 mm

Note: The backlight can be replaced in our factory.

The LCD must be replaced at the same time.

### ■ Recommended solderless terminal

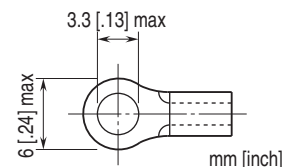

## INPUT SPECIFICATIONS

### ■ DC Voltage

**Input resistance:** 900 kΩ min.

Excluding the case in which, with range setting other than ±12 V, ±6 V or ±3 V, a voltage exceeding ±1.3 V is applied.

**Input range:** ±60 mV, ±125 mV, ±250 mV, ±500 mV, ±1000 mV, ±3 V, ±6 V, ±12 V

## ■ Thermocouple

**Input resistance:** 900 kΩ minimum

**Input type:** (PR), K (CA), E (CRC), F (IC), T (CC), B (RH), R, S, C (WRe 5-26), N, U, L, P (Platinel II)

## Burnout sensing

**Upscale:** ≤ 130 nA

**Downscale:** ≤ 220 nA

**No burnout:** ≤ 10 nA

## Burnout sensing time

**K, E, J, N, L, P (upscale):** ≤ 20 seconds

**Others:** ≤ 10 seconds

## ■ RTD (3-wire)

**Excitation:** 1.25 V / (1.25 kΩ + load resistance across the terminals A - C); 1.00 mA with 10 Ω across A - C; 0.55 mA with 1000 Ω across A - C

**Allowable leadwire resistance:** 20 Ω per wire

**Input type:** Pt 100 (JIS '89), Pt 100 (JIS '97, IEC), Pt 200, Pt 300, Pt 400, Pt 500, Pt 1000, Pt 50Ω (JIS '81), JPt 100 (JIS '89), Ni 100, Ni 120, Ni 508.4Ω, Ni-Fe 604, Cu 10 @ 25°C

## Burnout sensing

**Upscale or Downscale:** ≤ 130 nA

**No burnout:** ≤ 10 nA

**Burnout sensing time:** ≤ 10 seconds

**■ Trigger Input:** Dry contact; detected ON at ≤ 0.8 V

**Voltage across the terminals:** ≤ 2.5 V

**Current across the terminals:** ≤ 4.0 mA

## ■ ANALOG INPUT UPDATE CYCLE

LINE NOISE FILTER FREQ.	A/D CONVERSION (sec)			
	MEDIUM*1	SLOW	FAST	100 ms RATE
50 Hz	0.39	0.54	0.27	0.095
50/60 Hz*1	0.37	0.50	0.25	
60 Hz	0.34	0.46	0.23	

Multiplied by two (2) for RTD and potentiometer input.

\*1. Standard setting

## OUTPUT SPECIFICATIONS

**■ Alarm Output:** Photo MOSFET relay (no polarity); ≤ 50 Ω at ON, ≥ 1 MΩ at OFF; OFF when not powered

**Peak load voltage:** 50 V max.

**Continuous load current:** 50 mA max.

**Peak load current:** 300 mA max. (≤ 0.1 sec.)

## INSTALLATION

### Power consumption

#### •AC:

Approx. 25 VA at 100 V

Approx. 35 VA at 240 V

•DC: Approx. 11 W or 460 mA

**Operating temperature:** 0 to 50°C (32 to 122°F)

Display quality (e.g. decreased contrast) may deteriorate when the recorder is used for a long time in an environment

exceeding 50°C. However, it is only a temporary phenomenon. When the recorder is back in normal temperature, full legibility is recovered. No damage in performance.

**Operating humidity:** 30 to 85 %RH (non-condensing)

**Allowable dust particles:** 0.1 mg/m<sup>2</sup> (no conductive particles)

**Corrosive gas:** Not allowed

**Mounting:** Panel flush mounting (except desktop type)

**Panel cutout dimensions:** 137 × 137 mm (5.39" × 5.39")

## Weight

73VR2102, 73VR2104, 73VR2106: 2.3 kg (5.1 lb)

73VR2108, 73VR2110, 73VR2112: 2.4 kg (5.3 lb)

Caution: Use of UPS (switching time: without delay, output: sine waveforms) is recommended to prevent data loss or CF card damage by a loss of power during recording.

## PERFORMANCE

**Accuracy:** See Tables 1 through 3.

**Cold junction compensation error:** (°C)

≤ ±[1.0 + |Ambient Temp. - 25| × 0.04]

(in stable ambient temperature; e.g. ±1.4°C at 15°C and 35°C)

Applicable with balanced terminal temperature.

Error will increase by imbalances caused by direct mounting of the REM3 to the terminals.

**Temp. coefficient:** See Table 4.

## Response time

**DC of ±1000 mV or narrower ranges or T/C:**

≤ [Sampling Time + 0.3 sec.] (0 - 90 %)

**DC of ± 3 V or wider ranges:**

≤ [Sampling Time + 0.5 sec.] (0 - 90 %)

**RTD:** ≤ [Sampling Time + 0.3 sec.] (0 - 90 %)

**Calendar clock accuracy:** Monthly deviation 3 minutes at 25°C

**Insulation resistance:** ≥ 100 MΩ with 500 V DC

**Dielectric strength:** 500 V<sub>peak</sub> @ 1 minute

(input 1 to input 2 to input 3 to input 4 to

input 5 to input 6 to input 7 to input 8 to

input 9 to input 10 to input 11 to input 12 to trigger input to

alarm output to power input or FG)

Peak value including both AC and DC (e.g. 354 V AC with 0 V DC).

Nominal withstand voltage between I/O (analog input, trigger input and alarm output) and power input is described 500 V peak. However, as far as FG terminal is appropriately grounded, no dielectric breakdown will occur between I/O (with or without grounding) and other terminals when 2000 V AC is applied between FG and power input.

**AC power input:** 2000V AC @ 1 minute (power input to FG or Ethernet) 500 V AC @ 1 minute (FG to Ethernet)

**DC power input:** 1250 V AC @ 1 minute (power input to FG or Ethernet) 500 V AC @ 1 minute (FG to Ethernet)

**Line noise normal mode rejection:  $\geq 100$  dB**

Magnitude of the effects of normal mode 50/60 Hz noise, with the most appropriate line noise filter frequency setting. Each input circuit has a CR filter of sufficient large time constant so that there will be little effect of line noise such as 500 mV AC superposed on a thermocouple or  $\pm 60$  mV input.

**Common mode noise rejection**

Magnitude of the effects of voltages applied across the terminal C and the ground terminal when there is no potential difference among all the C terminals.

**DC:** N/A

**AC,  $\pm 3$  V,  $\pm 6$  V,  $\pm 12$  V:** Approx. 86 dB

**AC, other ranges:** Approx. 120 dB

**Common mode noise rejection between channels**

Magnitude of the effects of DC/50/60 Hz voltages applied across the terminals C of the present and the last scanned channels.

**DC,  $\pm 3$  V,  $\pm 6$  V,  $\pm 12$  V:** Approx. 100 dB

**DC, other ranges:** Approx. 120 dB

**AC,  $\pm 3$  V,  $\pm 6$  V,  $\pm 12$  V:** Approx. 86 dB

**AC, other ranges:** Approx. 106 dB

## STANDARDS & APPROVALS

**EU conformity:**

(M2 AC power of desktop type does not conform to EU directive)

## EMC Directive

EMI EN 61000-6-4

EMS EN 61000-6-2

## Low Voltage Directive

EN 61010-1

Installation Category II

Pollution Degree 2

Input 1 or 2 or 3 or 4 or 5 or 6 or 7 or 8 or 9 or 10 or 11 or 12 to power to FG or Ethernet: Reinforced insulation (300 V)

## RoHS Directive

## INPUT TYPE, RANGE, ACCURACY & TEMPERATURE COEFFICIENT

\* Accuracy: Applicable with the common mode voltage 0V between C terminals of all channels and between C terminal of each channel and FG terminal.

The effects by the following factors are excluded: Fast A/D conversion mode; temperature drift with the REM3 directly mounted to the I/O terminals; wire resistance; burnout sensing current with upscale/downscale settings.

With 100 msec. storing rate, measured value may be susceptible to inaccuracies due to the fast update cycle. If this is the case, please choose 500 msec. or slower rate.

**Table 1. DC Voltage Input**

INPUT RANGE	ACCURACY (mV)
±60 mV	±0.05
±125 mV	±0.07
±250 mV	±0.13
±500 mV	±0.3
±1000 mV	±0.5
±3 V	±3
±6 V	±5
±12 V	±10

**Table 2-1. Thermocouple Input, Celsius**

T/C	USABLE RANGE (°C)	CONFORMANCE RANGE (°C)	ACCURACY (°C)
(PR)	0 to 1770	400 to 1770	±4.6
K (CA)	-270 to +1370	0 to 1370	±1.5
E (CRC)	-270 to +1000	0 to 1000	±0.8
J (IC)	-210 to +1200	0 to 1200	±1.0
T (CC)	-270 to +400	0 to 400	±1.3
B (RH)	100 to 1820	700 to 1820	±7.2
R	-50 to +1760	400 to 1760	±4.8
S	-50 to +1760	400 to 1760	±5.3
C (WRe 5-26)	0 to 2320	0 to 2320	±4.9
N	-270 to +1300	0 to 1300	±1.9
U	-200 to +600	0 to 600	±1.3
L	-200 to +900	0 to 900	±1.0
P (Platinal II)	0 to 1395	0 to 1395	±1.7

**Table 2-2. Thermocouple Input, Fahrenheit**

T/C	USABLE RANGE (°F)	CONFORMANCE RANGE (°F)	ACCURACY (°F)
(PR)	32 to 3218	752 to 3218	±8.3
K (CA)	-454 to +2498	32 to 2498	±2.7
E (CRC)	-454 to +1832	32 to 1832	±1.5
J (IC)	-346 to +2192	32 to 2192	±1.8
T (CC)	-454 to +752	32 to 752	±2.4
B (RH)	212 to 3308	1292 to 3308	±13.0
R	-58 to +3200	752 to 3200	±8.7
S	-58 to +3200	752 to 3200	±9.6
C (WRe 5-26)	32 to 4208	32 to 4208	±8.9
N	-454 to +2372	32 to 2372	±3.5
U	-328 to +1112	32 to 1112	±2.4
L	-328 to +1652	32 to 1652	±1.8
P (Platinal II)	32 to 2543	32 to 2543	±3.1

Note 1: Measuring accuracy at 50 µV emf.

Note 2: CJC error is not included.

**Table 3-1. RTD Input, Celsius**

RTD	USABLE RANGE (°C)	ACCURACY	
		at < 0°C	at ≥ 0°C
Pt 100 (JIS '97, IEC)	-200 to +850	±0.4°C	±[0.4°C + Measured Value × 0.1%] (±1.3°C at 850°C)
Pt 200	-200 to +850	±0.3°C	±[0.3°C + Measured Value × 0.17%] (±1.8°C at 850°C)
Pt 300	-200 to +850	±[0.4°C + Measured Value × 0.08%] (±0.3°C at -200°C)	±[0.4°C + Measured Value × 0.21%] (±2.2°C at 850°C)
Pt 400	-200 to +850	±[0.4°C + Measured Value × 0.11%] (±0.2°C at -200°C)	±[0.4°C + Measured Value × 0.21%] (±2.2°C at 850°C)
Pt 500	-200 to +850	±[0.4°C + Measured Value × 0.13%] (±0.2°C at -200°C)	±[0.4°C + Measured Value × 0.26%] (±2.6°C at 850°C)
Pt 1000	-200 to +850	±[0.4°C + Measured Value × 0.15%] (±0.1°C at -200°C)	±[0.4°C + Measured Value × 0.4%] (±3.8°C at 850°C)
Pt 100 (JIS '89)	-200 to +660	±0.4°C	±[0.4°C + Measured Value × 0.1%] (±1.1°C at 660°C)
JPt 100 (JIS '89)	-200 to +510	±0.4°C	±[0.4°C + Measured Value × 0.1%] (±1.0°C at 510°C)
Pt 50 Ω (JIS '81)	-200 to +649	±0.5°C at < 160°C, ±[0.4°C + Measured Value × 0.1%] at ≥ 160°C	(±1.1°C at 649°C)
Ni 100	-80 to +260	±0.3°C	
Ni 120	-80 to +260	±0.3°C	
Ni 508.4 Ω	-50 to +280	±[0.25°C + Measured Value × 0.06%]	(±0.3°C at -50°C, ±0.5°C at 280°C)
Ni-Fe 604	-200 to +200	±0.9°C at -200°C, ±0.6°C at -150°C, ±0.5°C at ±100°C, ±0.7°C at 200°C	
Cu 10 @ 25°C	-50 to +250	±1.2°C	

Note 1: The lower the temperature range, the better the accuracy is for Pt 300, Pt 400, Pt 500, Pt 1000 and Ni 508.4 Ω.

'Measured Value' in the equations is not an absolute value. Include the minus sign when calculating accuracies.

**Table 3-1. RTD Input, Fahrenheit**

RTD	USABLE RANGE (°F)	ACCURACY	
		at < 32°F	at ≥ 32°F
Pt 100 (JIS '97, IEC)	-328 to +1562	±0.8°F	±[0.72°F + Measured Value × 0.1%] (±2.4°F at 1562°F)
Pt 200	-328 to +1562	±0.6°F	±[0.54°F + Measured Value × 0.17%] (±3.3°F at 1562°F)
Pt 300	-328 to +1562	±[0.72°F + Measured Value × 0.08%] (±0.5°F at -328°F)	±[0.72°F + Measured Value × 0.21%] (±4.0°F at 1562°F)
Pt 400	-328 to +1562	±[0.72°F + Measured Value × 0.11%] (±0.4°F at -328°F)	±[0.72°F + Measured Value × 0.21%] (±4.0°F at 1562°F)
Pt 500	-328 to +1562	±[0.72°F + Measured Value × 0.13%] (±0.3°F at -328°F)	±[0.72°F + Measured Value × 0.26%] (±4.7°F at 1562°F)
Pt 1000	-328 to +1562	±[0.72°F + Measured Value × 0.15%] (±0.2°F at -328°F)	±[0.72°F + Measured Value × 0.4%] (±6.9°F at 1562°F)
Pt 100 (JIS '89)	-328 to +1220	±0.8°F	±[0.72°F + Measured Value × 0.1%] (±2.0°F at 1220°F)
JPt 100 (JIS '89)	-328 to +950	±0.8°F	±[0.72°F + Measured Value × 0.1%] (±1.7°F at 950°F)
Pt 50 Ω (JIS '81)	-328 to +1200	±0.9°F at < 320°F, ±[0.72°F + Measured Value × 0.1%] at ≥ 320°F (±1.9°F at 1200°F)	
Ni 100	-112 to +500	±0.6°F	
Ni 120	-112 to +500	±0.6°F	
Ni 508.4 Ω	-58 to +536	±[0.45°F + Measured Value × 0.06%] (±0.4°F at -58°F, ±0.8°F at 536°F)	
Ni-Fe 604	-328 to +392	±1.7°F at -328°F, ±1.1°F at -238°F, ±0.9°F at ±212°F, ±1.3°F at 392°F	
Cu 10 @ 25°C	-58 to +482	±2.2°F	

Note 1: The lower the temperature range, the better the accuracy is for Pt 300, Pt 400, Pt 500, Pt 1000 and Ni 508.4 Ω.  
 'Measured Value' in the equations is not an absolute value. Include the minus sign when calculating accuracies.

**Table 4. Temperature Coefficient**

INPUT TYPE	TEMPERATURE COEFFICIENT	
DC Voltage	±[Nominal Input Range × 0.015%/°C or ±[Nominal Input Range × 0.008%/°F (e.g. ±0.018mV/°C with ±60mV range)	
Thermocouple	±[Accuracy / 3] °C/°C or ±[Accuracy / 3] °F/°F (e.g. ±0.27°C/°C with E thermocouple)	
RTD	at < 0°C or 32°F	at ≥ 0°C or 32°F
Pt 100 (JIS '97, IEC)	±0.041°C/°C ±0.041°F/°F	±[0.041°C + Measured Value × 0.026%]/°C ±[0.041°F + Measured Value × 0.026%]/°F
Pt 200	±0.044°C/°C ±0.044°F/°F	±[0.044°C + Measured Value × 0.033%]/°C ±[0.044°F + Measured Value × 0.033%]/°F
Pt 300	±0.047°C/°C ±0.047°F/°F	±[0.047°C + Measured Value × 0.04%]/°C ±[0.047°F + Measured Value × 0.04%]/°F
Pt 400	±0.05°C/°C ±0.05°F/°F	±[0.05°C + Measured Value × 0.052%]/°C ±[0.05°F + Measured Value × 0.052%]/°F
Pt 500	±0.053°C/°C ±0.053°F/°F	±[0.053°C + Measured Value × 0.053%]/°C ±[0.053°F + Measured Value × 0.053%]/°F
Pt 1000	±[0.068°C + Measured Value × 0.025%]/°C ±[0.068°F + Measured Value × 0.025%]/°F	±[0.068°C + Measured Value × 0.087%]/°C ±[0.068°F + Measured Value × 0.087%]/°F
Pt 100 (JIS '89)	±0.041°C/°C ±0.041°F/°F	±[0.041°C + Measured Value × 0.024%]/°C ±[0.041°F + Measured Value × 0.024%]/°F
JPt 100 (JIS '89)	±0.041°C/°C ±0.041°F/°F	±[0.041°C + Measured Value × 0.023%]/°C ±[0.041°F + Measured Value × 0.023%]/°F
Pt 50 Ω (JIS '81)	±0.039°C/°C ±0.039°F/°F	±[0.039°C + Measured Value × 0.021%]/°C ±[0.039°F + Measured Value × 0.021%]/°F
Ni 100	±0.028°C/°C ±0.028°F/°F	±[0.028°C + Measured Value × 0.01%]/°C ±[0.028°F + Measured Value × 0.01%]/°F
Ni 120	±0.028°C/°C ±0.028°F/°F	±[0.028°C + Measured Value × 0.01%]/°C ±[0.028°F + Measured Value × 0.01%]/°F
Ni 508.4 Ω	±0.046°C/°C ±0.046°F/°F	±[0.046°C + Measured Value × 0.018%]/°C ±[0.046°F + Measured Value × 0.018%]/°F
Ni-Fe 604	±0.058°C/°C at ≤-200°C, ±0.043°C/°C at -150°C, ±0.04°C/°C at -100°C, ±[0.047°C + Measured Value × 0.023%]/°C at ≥0°C ±0.058°F/°F at ≤-328°F, ±0.043°F/°F at -238°F, ±0.04°F/°F at -148°F, ±[0.047°F + Measured Value × 0.023%]/°F at ≥32°F	
Cu 10 @ 25°C	±0.07°C/°C or ±0.07°F/°F	

## APPLICATION SOFTWARE CD

### ■ 73VRPAC2 (included in the product package)

- 73VR21x Builder Software: Model 73VR21BLD

Used to configure parameters on the PC.

- Parameter configurations can be downloaded to the recorder via Ethernet.
- Present setting on the 73VR21x can be uploaded and displayed on the PC.
- Configuration files can be converted into CSV.

- 73VR Data Viewer: Model 73VRWV

Used to show and analyze recorded data on the PC.

- Data stored in the CF Card can be called up on the PC screen via the CF Card Reader.
- Data stored in the CF Card can be sent by FTP and called up on the PC screen.
- Various analyzing functions
- Data, alarm history and comment files can be converted into CSV.

- PC Recorder Software: Model MSR128-V6

- The 73VR21x data can be sampled and stored in real time via Ethernet by the MSR128-V6.

- Instruction Manuals

- 73VR21x users manual
- 73VR21BLD users manual
- 73VRWV users manual
- MSR128-V6 users manual

## PC REQUIREMENTS (provided by the user)

### ■ 73VR21x Builder Software: Model 73VR21BLD

Operating system	Windows 7 Professional (32-bit) or Windows 10 (32-bit, 64-bit) Note: Proper software functions may not be ensured under certain conditions.
Screen area	1024 by 768 pixels or better resolution
CD drive	Windows supported CD drive is used to install the software program.
Card reader	Used to read/write the CF Card
Mouse	Windows supported
LAN card	LAN card required to connect to Ethernet; 10BASE-T or 100BASE-T cable

### ■ 73VR Data Viewer: Model 73VRWV

Operating system	Windows 7 Professional (32-bit) or Windows 10 (32-bit, 64-bit) Note: Proper software functions may not be ensured under certain conditions.
Screen area	1024 by 768 pixels or higher
Display color	65000 colors (16-bit)
Main memory (RAM)	2 GB recommended
CD drive	Windows supported CD drive is used to install the software program.
Card reader	Used to read/write the CF Card
Mouse	Windows supported (Certain functions of the 73VR may be compromised if the mouse's software driver is not Windows standard.)
LAN card	LAN card required to connect to Ethernet; 10BASE-T or 100BASE-T cable

### ■ PC Recorder Software: Model MSR128-V6

Refer to the specifications of MSRPAC-2010, which contains MSR128-V6, for the operating environment (provided by user) required for MSR128-V6.

## EXTERNAL VIEW

### ■ FRONT VIEW • 73VR21x

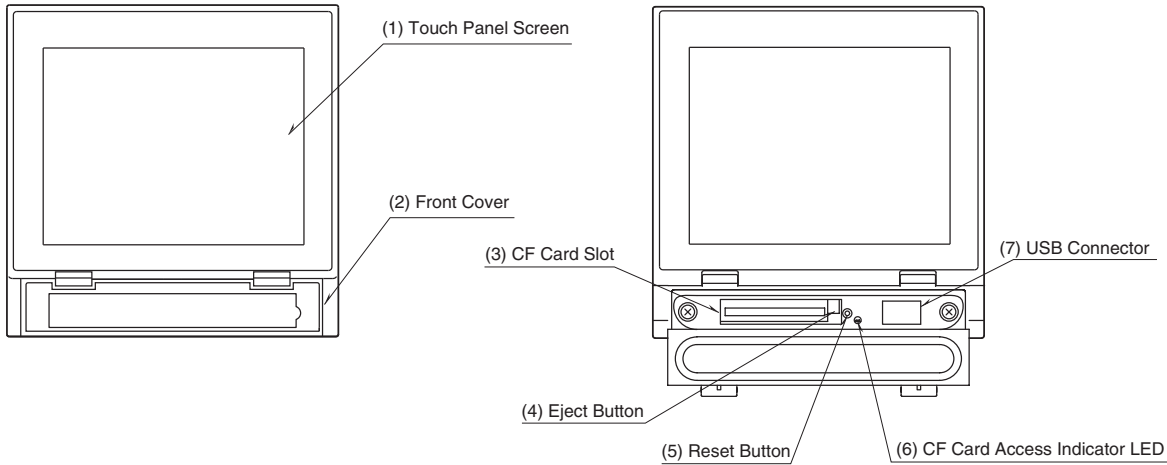

### ■ REAR VIEW • 73VR2102, 73VR2104, 73VR2106

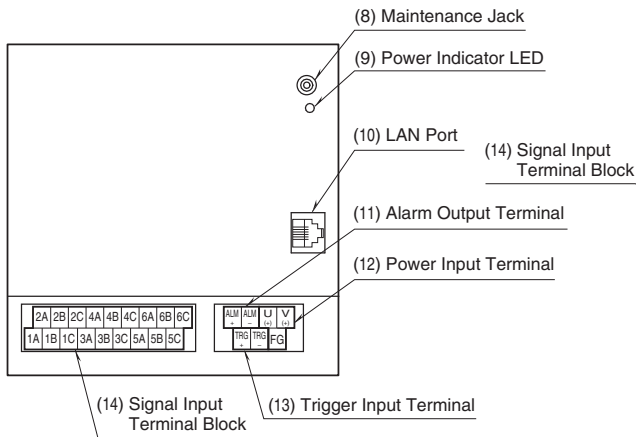

### • 73VR2108, 73VR2110, 73VR2112

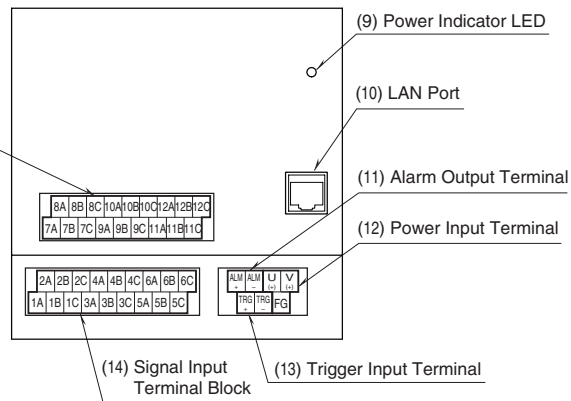

### ■ SIDE VIEW • 73VR2108, 73VR2110, 73VR2112

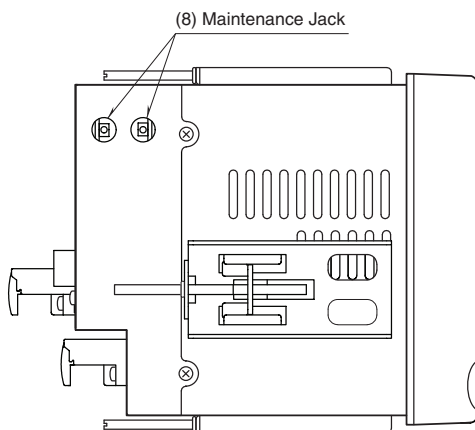

- (1) Touch Panel Screen  
Trend chart and other data views and setup views are displayed.
- (2) Front Cover  
Access to the CF Card Slot.
- (3) CF Card Slot  
Insert a CF Card.
- (4) Eject Button  
Used to retrieve the CF Card.
- (5) Reset Button  
Used to restart the 73VR21x.
- (6) CF Card Access Indicator LED  
Red LED turns on during the CF Card is accessed.
- (7) USB Connector  
Connect an USB flash-memory.
- (8) Maintenance Jack  
Unused
- (9) Power Indicator LED  
LED turns on while the power is supplied.
- (10) LAN Port  
Connects the LAN cable (10BASE-T or 100BASE-TX)
- (11) Alarm Output Terminal
- (12) Power Input Terminal
- (13) Trigger Input Terminal
- (14) Signal Input terminal Block



## CONNECTION DIAGRAM

Note: In order to improve EMC performance, bond the FG terminal to ground.

Caution: FG terminal is NOT a protective conductor terminal.

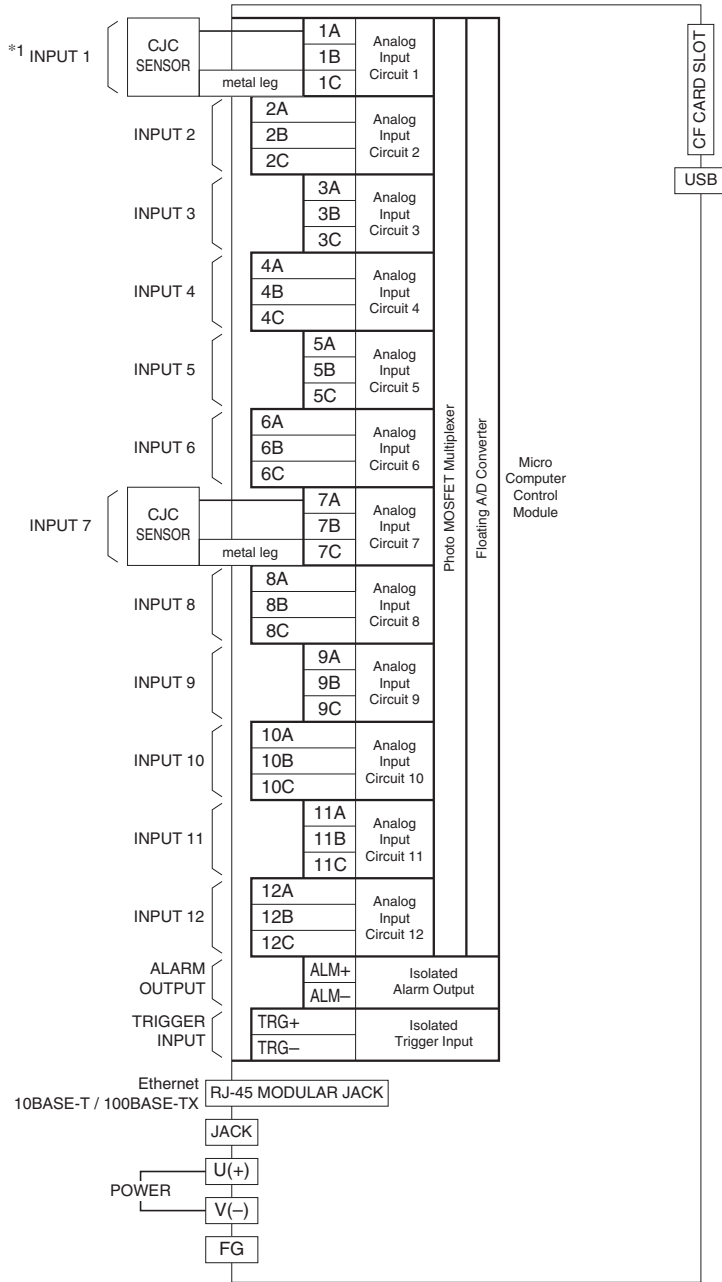

\*1. Usable terminals depend upon the number of inputs.

### Input Connection Examples

- DC INPUT
- T/C INPUT
  - Upscale / No Burnout
  - Downscale Burnout
- RTD INPUT

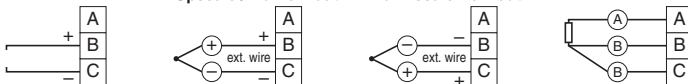

Note 1: In order to prevent instability in measured values caused by noise entering through the I/O terminals, grounding the signal shield to a most stable earth point in the environment is recommended.

Note 2: The smaller is common mode voltage (DC and AC) between C terminals and between C and FG, the better is measuring accuracy. Connecting between C terminals and if possible to FG will yield the best accuracy.

Note 3: Resistor modules (model: REM3-250) can be connected to 1A through 12C terminals to convert current inputs into voltage. However, it is not recommended when TC inputs are mixed because the heat developed on and around the REM3 affects the cold junction compensation performance. We recommend that REM3 be connected on a separate terminal board.

Note 4: When the internal temperature sensors are used for CJC, temperature imbalance around the terminal block affects greatly the CJC accuracy. In order to minimize such imbalance, do not use wires of large diameter which has large heat dissipation. Be sure to close the terminal cover. Do not expose the module directly in the line of wind from a cooling fan.

**EXTERNAL DIMENSIONS unit: mm [inch]**

■ 73VR2102, 73VR2104, 73VR2106

· Panel mount type

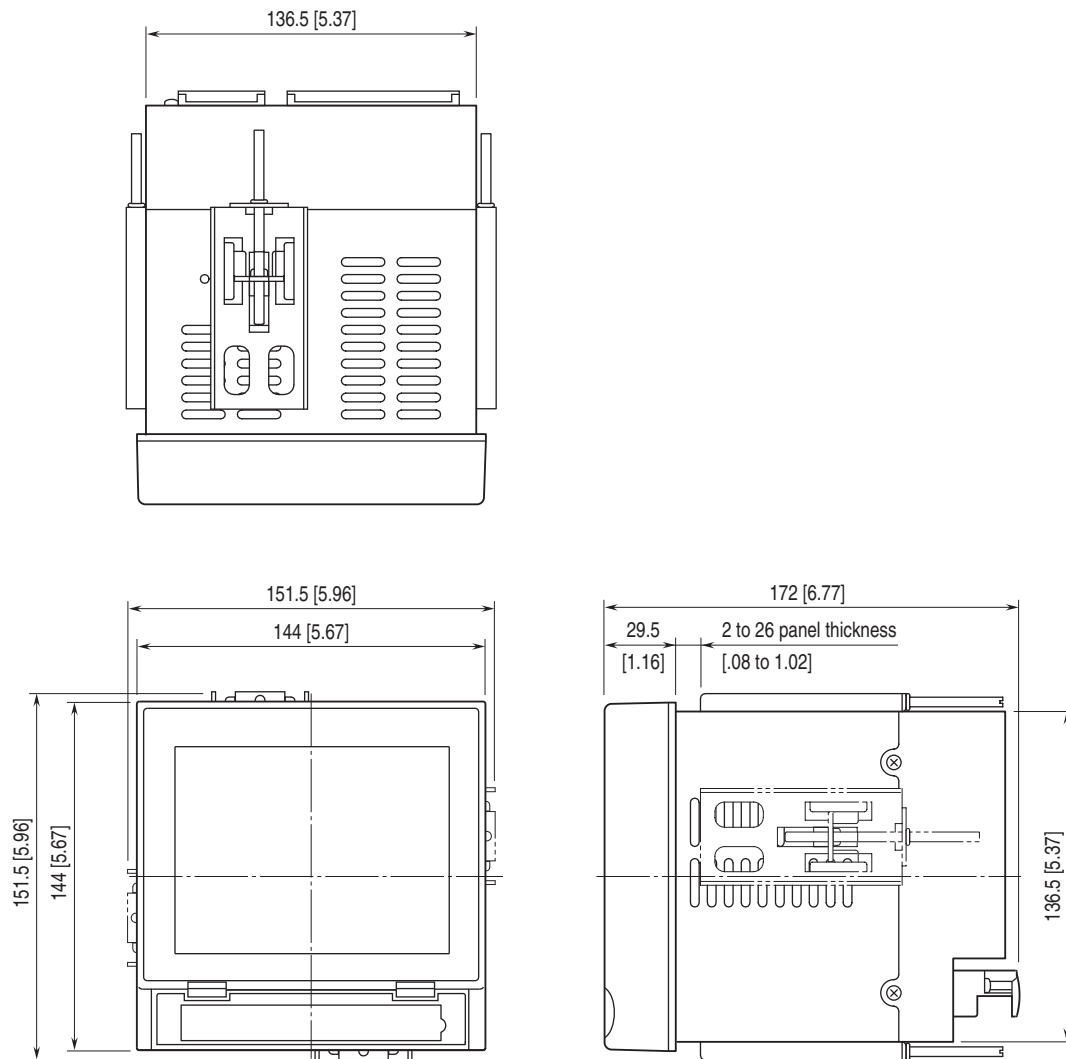

Attach the mounting bracket either on the top/bottom or on the sides.

· Desktop type

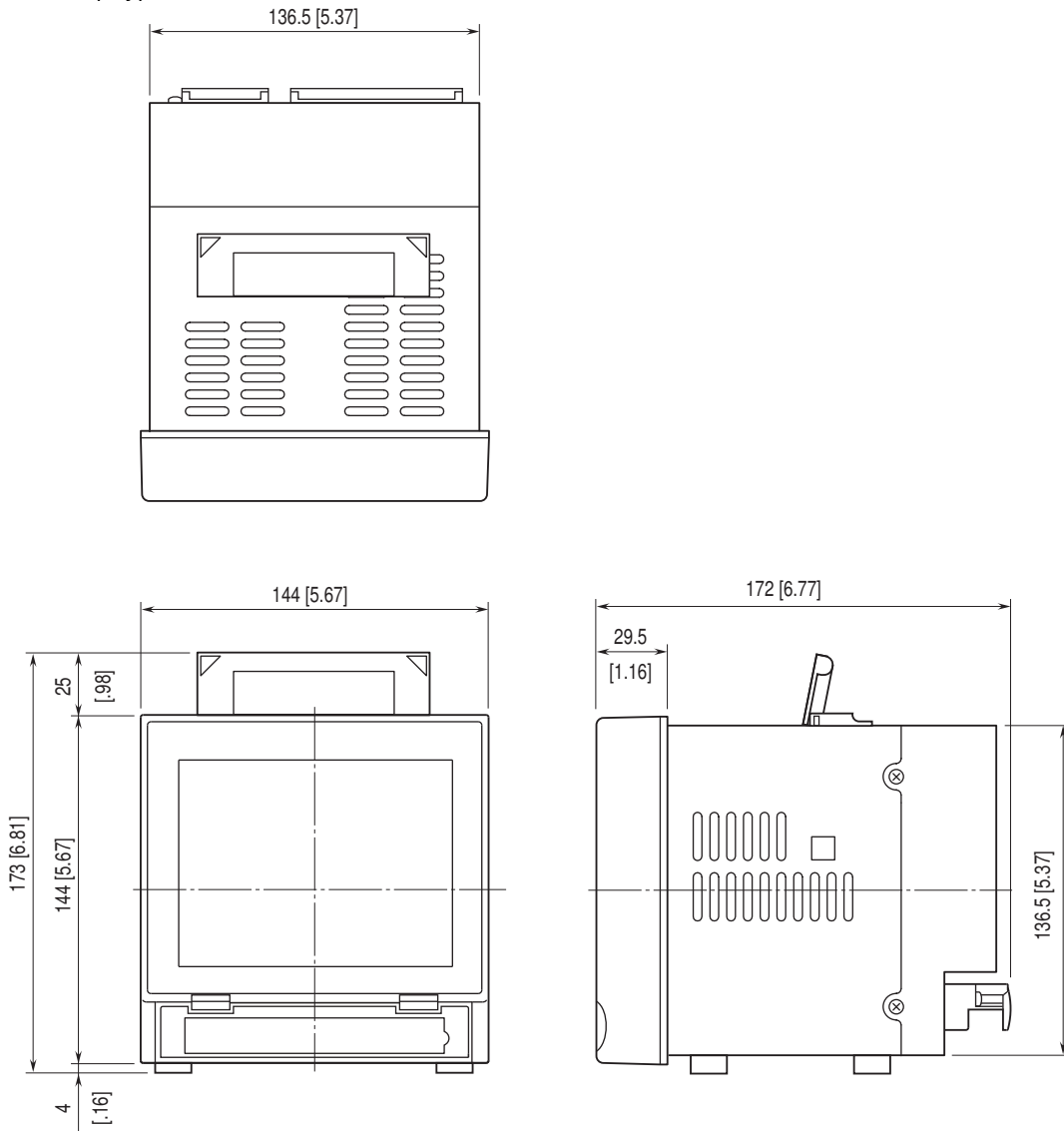

The handle and rubber feet cannot be detached from desktop type unit.

■ 73VR2108, 73VR2110, 73VR2112

· Panel mount type

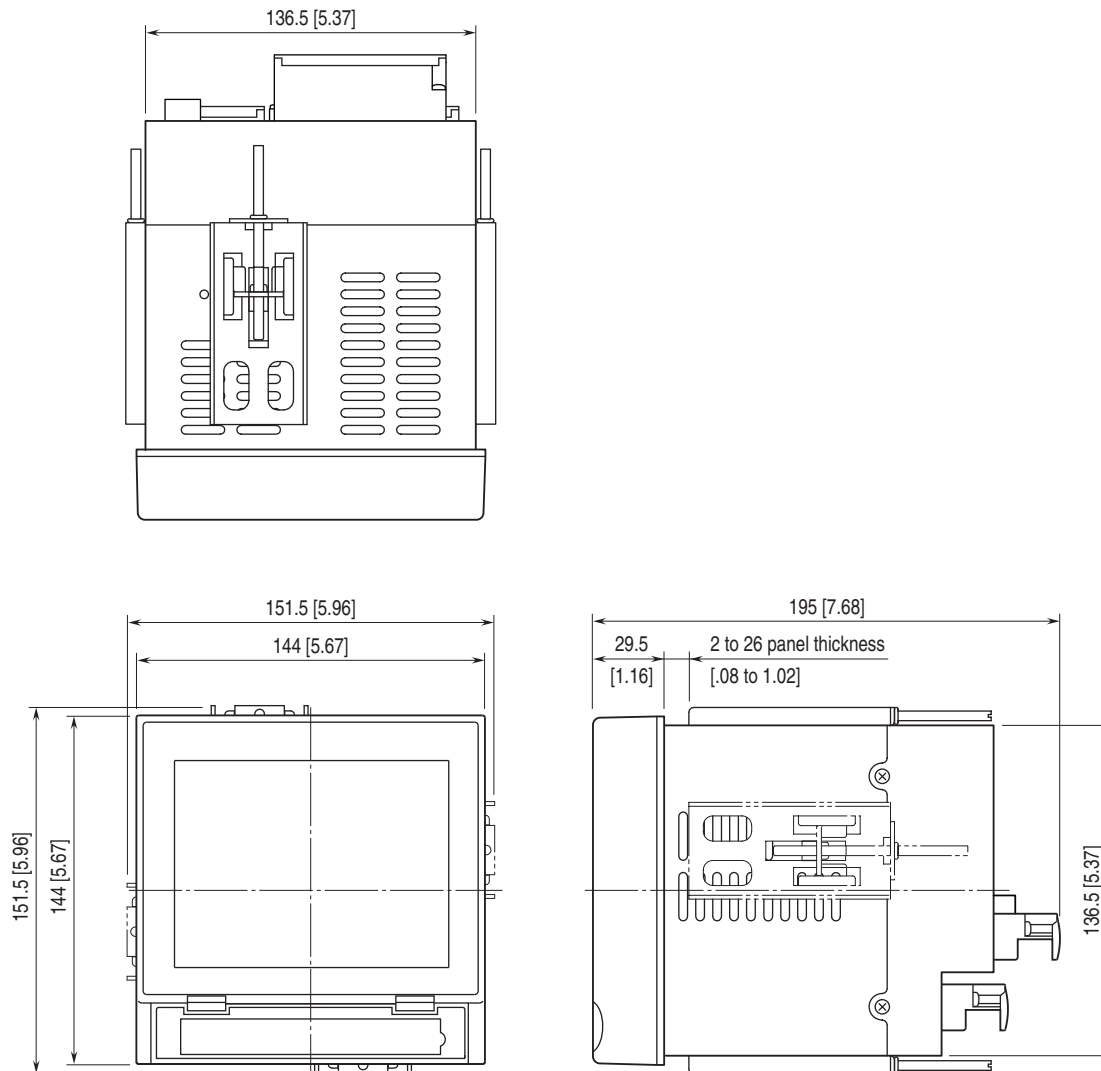

Attach the mounting bracket either on the top/bottom or on the sides.

· Desktop type

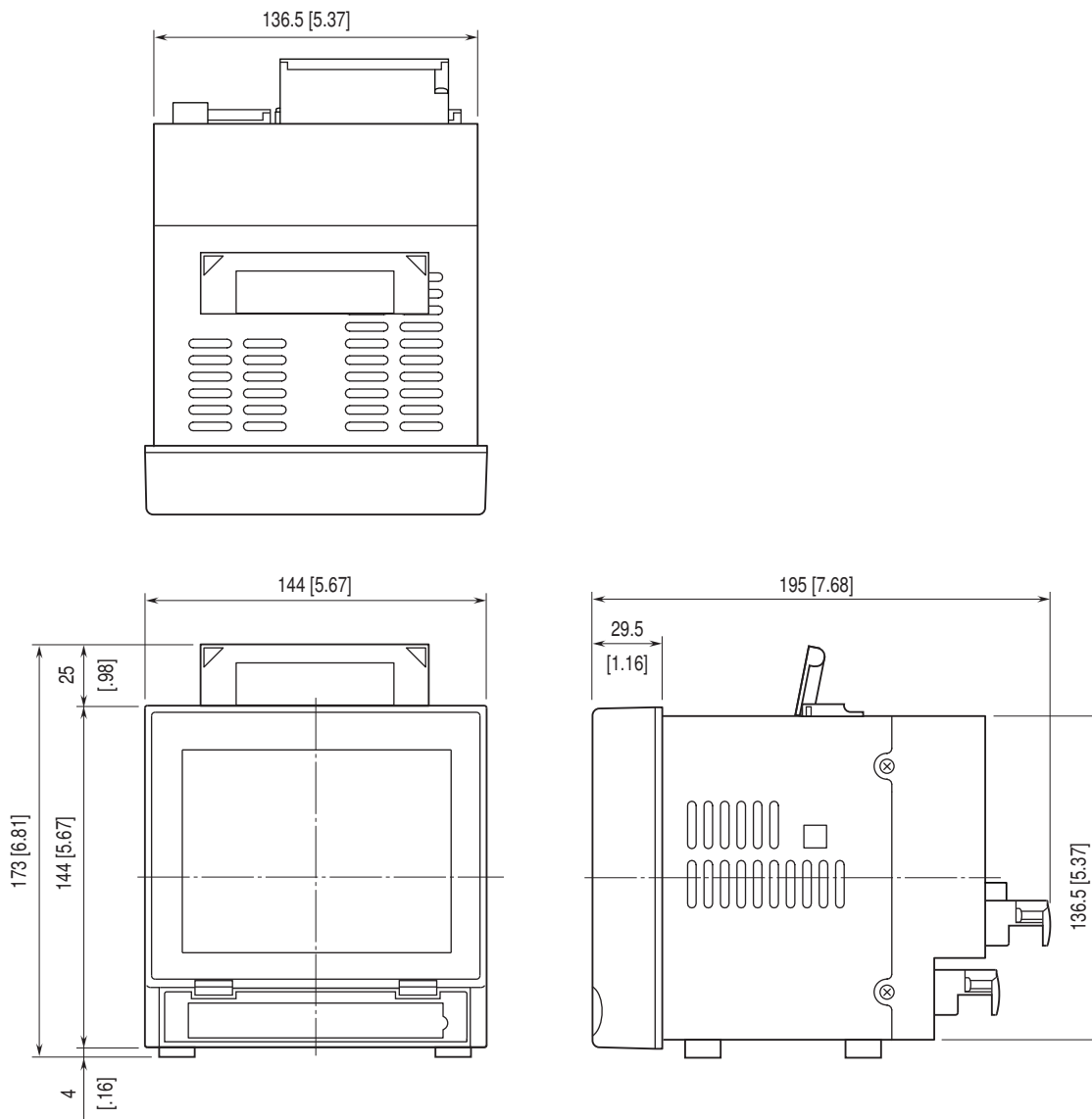

The handle and rubber feet cannot be detached from desktop type unit.

## PANEL CUTOUT unit: mm

Usable panel thickness: 2 - 26 mm [0.08" - 1.02"]

### ■ SINGLE MOUNTING

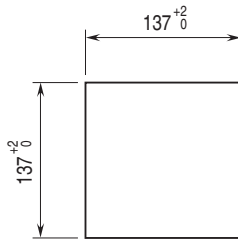

Number	L <sup>+2</sup> / <sub>0</sub> (mm)
2	282
3	426
4	570
5	714
6	858
7	1002
8	1146
9	1290
10	1434
n	(114 × n) - 6

#### Notes

1. Dimensional tolerance ±3% unless otherwise specified. (±0.3 mm for < 10 mm)
2. Desktop type cannot be mounted on a panel surface.

### ■ VERTICAL CLUSTERED MOUNTING (max. 3 units)

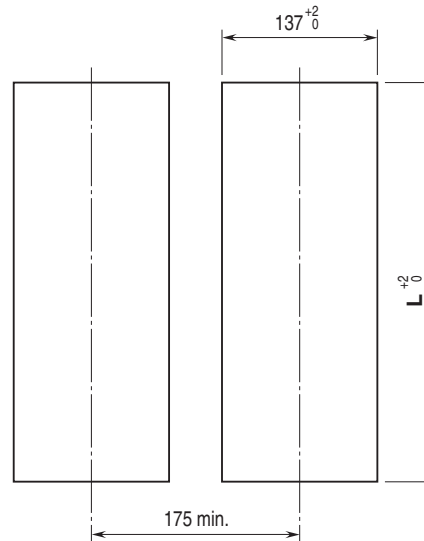

### ■ HORIZONTAL CLUSTERED MOUNTING

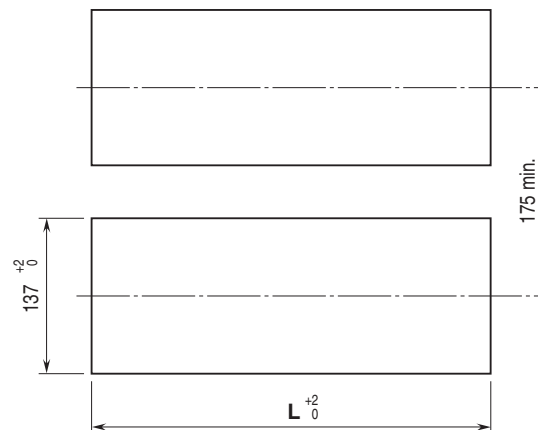

## SOFTWARE FUNCTIONS

### ■ NUMBER OF INPUT PEN POINTS

- 73VR2102: 2 points
- 73VR2104: 4 points
- 73VR2106: 6 points
- 73VR2108: 8 points
- 73VR2110: 10 points
- 73VR2112: 12 points

### ■ INPUT SIGNALS

**Analog:** DC mV and voltage, thermocouple and RTD

**Discrete:** Trigger input (1 point)

### ■ DATA STORING METHOD

**Normal:** Recording is manually initiated and stopped. Data is continuously stored while the recording is on.

**Auto:** Recording is automatically initiated and stopped at a predefined time.

**Event recording:** The recorder detects an external event by trigger signal, and stores preset number of samples (max. 1200 respectively) before and after the moment of event.

**Remote trigger:** Data is automatically recorded while the external trigger condition (input) is true.

### ■ STORING RATE

0.1 (DC voltage input only) 0.5, 1, 2, 5, 10 sec., 1, 10 minutes

### ■ DATA STORAGE

**Data file:** Stores momentary values in the storing rate and their calculation result.

**Alarm history file:** Records time index information when

alarms are triggered and reset.

Oldest data is overwritten with new data when the number of records reaches its limit.

**Comment history file:** Records comments written in trend views with time index. Oldest data is overwritten with new data when the number of records reaches 1000 files.

**Configuration file:** Stores the 73VR21x setting.

**File format:** Binary

Oldest measured data is overwritten with new data or data recording is stopped when the card memory is full.

## ■ ALARM

### • Analog Alarm

**Alarm setpoints:** Max. 4 points per channel

**Alarm type:** High / Low

**Deadband:** Set in engineering unit values

**Output:** 1 point at Alarm Output

**Terminal stored information:** Date/time of alarm events (trip and reset), Pen No., Tag Name and Alarm Message

**Number of stored alarm events:** Depends upon the CF Card capacity.

128 MB 250 events

256 MB 500 events

512 MB or 1 GB 1000 events

## ■ CALCULATION FUNCTIONS

**Number of channels:** 12 channels

### Operations

**Arithmetic:** Addition/subtraction, Multiplication, Division

**Logical:** AND, OR, NOT, XOR

**Mathematical:** Square root extractor, Power

**Accumulation:** Analog accumulation

**Filter:** Moving average, First order lag

**Hold:** Peak (maximum) hold (tracking increasing signal),

Peak (minimum) hold (tracking decreasing signal)

**F value:** F value

### Anemoscope (16 directions)

**Alarm:** Alarm trip can be programmed for calculated results.

## ■ DATA DISPLAY FUNCTIONS

### • Trend View

**Chart direction:** Perpendicular or horizontal

**Number of pens displayed:** 2, 4, 6, 8 per view

**Number of display views:** 4

**Chart speed:** Chart speed is described as number of pixels to plot single data sample. (pixel(s)/samples)

4, 1, 1/5, 1/32,

1/160 (not selectable with 100 msec. storing rate),

1/480 (not selectable with 100 msec. storing rate),

1/960 (not selectable with 100 msec. storing rate)

**Display rate:** 1 second

**Pen thickness:** Normal and wide

**Digital indicator:** Shows momentary value.

**Alarm indicator:** Shows alarm status of the channels displayed on the screen.

**Comment:** Shows comments entered manually.

**Scale:** Linear and square root;

Switchable to the engineering unit scale.

### • Bargraph View

**Bargraph direction:** Perpendicular or horizontal

**Number of pens displayed:** 2, 4, 6, 8 per view

**Number of display views:** 4

**Display rate:** 1 second

**Digital indicator:** Shows momentary value.

**Alarm indicator:** Shows alarm status of the channels displayed on the screen.

**Scale:** Linear and square root;

Switchable to the engineering unit scale.

### • Overview

**Number of pens displayed:** 2, 4, 6, 8, 16 per view

**Number of display views:** 13

**Display rate:** 1 second

**Alarm indicator:** Shows alarm status and date/time of the last alarm trip and reset for the channels displayed on the screen.

### • Retrieve View: Shows data stored in the CF Card.

**Number of pens displayed:** 2, 4, 6, 8 per view

**Number of display views:** 4

**Data search:** Scrolling the chart, specifying a specific time index, or searching by maximum/minimum values.

**Long span view:** Retrieved data is thinned out so that a longer time span can be displayed on the chart.

### • Alarm History View: Shows data stored in the alarm history file.

**Number of displayed alarm events:** 16

**Number of display views:** 1

**Display update:** Automatically updated by a new event

**Data search:** Scrolling the view or specifying a specific time index.

**Jump:** Scroll the view to an alarm event to show the relevant data on Retrieve View.

### • Comment History View: Shows data stored in the comment history file.

**Number of displayed alarm events:** 16

**Number of display views:** 1

**Data search:** Scrolling the view or specifying a specific time index.

**Jump:** Scroll the view to a comment to show the relevant data on Retrieve View.

## ■ ETHERNET COMMUNICATION

Monitoring data and setup of the 73VR21x is possible on the PC connected via Ethernet.

• **Dedicated Protocol**

**Real time communication:** Transmits specific data to a host PC installed with the PC Recorder Software (model: MSR128).

**FTP communication:** Transmits data stored in the CF Card using the FTP protocol to a host PC by the 73VR Data Viewer (model: 73VRWV) installed in it. Data can be transmitted even during recording.

**Download, Upload:** Software configurations created on the 73VR21x Configuration Builder (model:73VR21BLD) can be downloaded to the 73VR21x. The configuration set up on the 73VR21x can be uploaded and displayed on the 73VR21BLD.

• **Modbus Protocol**

**Protocol:** Modbus/TCP

**Port No.:** 502 (fixed)

**IP address:** Set on the recorder

**Subnet mask:** Set on the recorder

**Default gateway:** Set on the recorder

**Max. number of 73VR21x connected simultaneously:** 2

**Supported Function Codes**

CODE	NAME	FUNCTION
01	Read Coil Status	Reads DO
02	Read Input Status	Reads DI
04	Read Input Register	Reads Input Register
11	Fetch Communication Event Counter	Reads Status Word and Event Counter from Comm. Event Counter

**Exception Response**

CODE	NAME	FUNCTION
01	Illegal Function	Function Not supported
02	Illegal Data Address	Specified address does not exist

**Supported Function Codes**

	ADDR.	TYPE	NAME
Coil (0X)	1		Discrete output
Input Status (1X)	1		Trigger input
	3		Discrete input (73VR2102)
	5		Discrete input (73VR2104)
	7		Discrete input (73VR2106)
	9		Discrete input (73VR2108)
	11		Discrete input (73VR2110)
	13		Discrete input (73VR2112)
	14 – 25		Function data (discrete)
Input Register (3X)	1 – 24	F	Measured data (analog)
	25 – 48	F	Function data (analog)

■ **OTHER FUNCTIONS**

• **Operation Lockout**

With a password setting, unauthorized operations on the Trend View, Bargraph View and Overview can be locked out.

• **Data File Used Volume Information**

A bargraph with % indication is provided on the screen to show how much percent of the data file memory has been used up.

0 – 49 % used: Green bargraph

50 – 79 % used: Amber bargraph

80 – 100 % used: Red bargraph

• **Hot Swapping of the CF Card**

The CF Card is hot swappable: removable during data recording. However, there may be a slight disturbance in storing rate when the card is inserted.

• **Screen Saver**

The backlight is automatically turned off if the screen is untouched for a certain time period.

• **Bus Error Alert**

An alarm is output at Alarm Output Terminal in case of internal bus error.

• **Writing/Reading Setting**

The recorder's present setting can be stored in a USB flash-memory. Setting stored in the memory can be read in to the 73VR21x.

• **Hardware Setting**

Burnout, Cold junction compensation, AD conversion mode, line noise filter

• **Field Calibration**



## STORABLE TIME DURATION IN 1GB CF CARD

STORING RATE	APPROXIMATE TIME DURATION					
	2 ch input	4 ch input	6 ch input	8 ch input	10 ch input	12 ch input
0.1 seconds	71 days	46 days	35 days	27 days	22 days	19 days
0.5 seconds	355 days	231 days	178 days	141 days	113 days	97 days
1 second	1 year, 351 days	1 year, 97 days	357 days	273 days	227 days	195 days
10 seconds	---	---	9 years, 219 days	7 years, 176 days	6 years, 86 days	5 years, 126 days
1 minute	---	---	---	---	---	---

--- : Exceeds 10 years

Note 1: Data are calculated ones, and thus not guaranteed.

Note 2: Assuming 4 bytes per data per channel.

Note 3: A year is calculated as 365 days.

## SYSTEM CONFIGURATION EXAMPLES

### INDEPENDENTLY USED

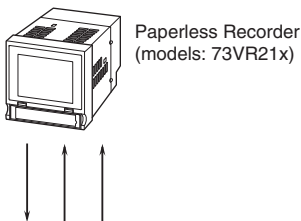

### INTERFACING WITH A PC

#### Reading Data from CF Card

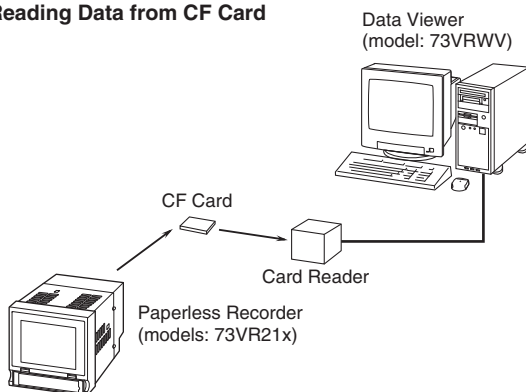

#### Ethernet Connection

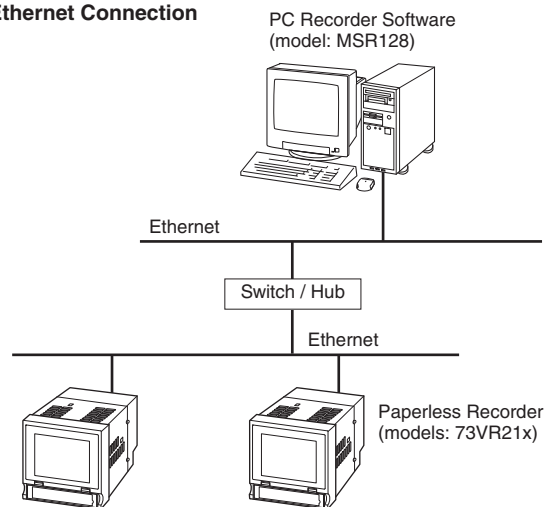

Note: It is recommended to connect the 73VR21x to the PC using straight cables via a switch/hub on the Ethernet.



Specifications are subject to change without notice.