

# MOUNTING FRAME

MODEL **BX-1DL**

## MODEL & SUFFIX CODE SELECTION

MODEL \_\_\_\_\_ **BX-1DL**  
CAPACITY  
1 unit

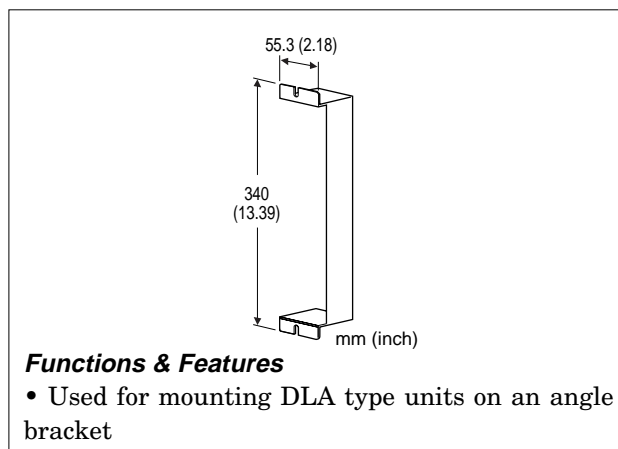

## ORDERING INFORMATION

Specify code number. (e.g. BX-1DL)

## GENERAL SPECIFICATIONS

**Construction:** angle bracket  
**Material:** SPCC; t=2.3  
**Coating:** melamine resin (black)  
**Capacity:** 1 unit

## INSTALLATION

**Operating temperature:** -5 to +50°C (23 to 131°F)  
**Operating humidity:** 30 to 90% RH (non-condensing)  
**Mounting:** angle bracket  
**Dimensions:** W55.3×H340×D50 mm (2.18"×1.34"×1.97")  
**Weight:** 350 g (0.77 lbs)

## EXTERNAL DIMENSIONS & MOUNTING REQUIREMENTS mm (inch)

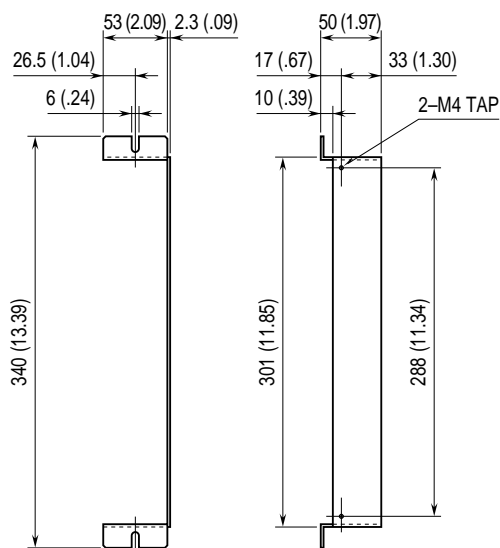

## ■ MOUNTING REQUIREMENTS

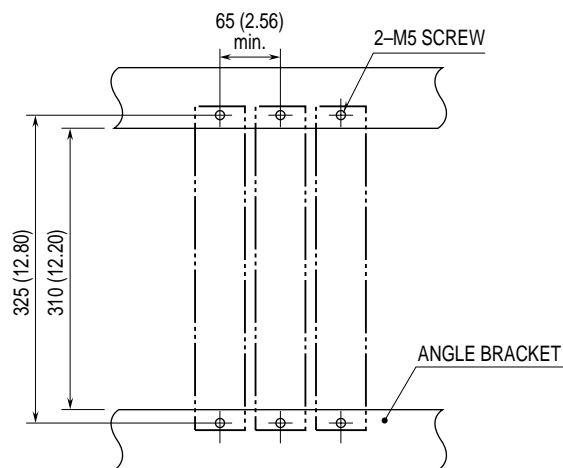

Specifications subject to change without notice.