

**Super-mini Two-wire Terminal Block
Signal Conditioners B5-UNIT**

RTD TRANSMITTER

Functions & Features

- Accepts direct input from a RTD and provides an isolated 4 – 20 mA signal
- Linearization and burnout
- Monitor terminals
- High-density mounting
- Power LED

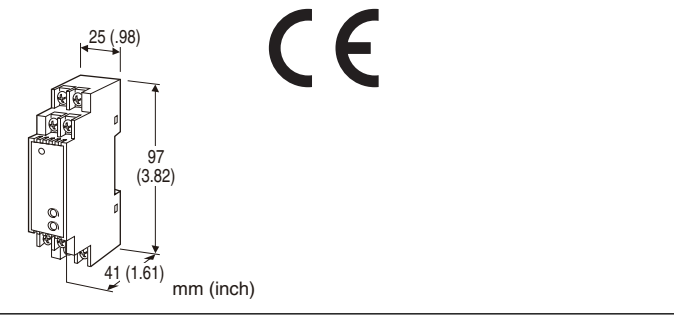

MODEL: B5RS-[1][2]

ORDERING INFORMATION

- Code number: B5RS-[1][2]
- Specify a code from below for each of [1] and [2].
(e.g. B5RS-4/K/BL/Q)
- Temperature range (e.g. 0 – 500°C)
- Specify the specification for option code /Q
(e.g. /C01)

[1] INPUT RTD (2- or 3-wire)

- 1:** JPt 100 (JIS'89)
(Usable range: -200 to +500°C, -328 to +932°F; min.span: 50°C, 90°F)
 - 3:** Pt 100 (JIS'89)
(Usable range: -200 to +650°C, -328 to +1202°F; min.span: 50°C, 90°F)
 - 4:** Pt 100 (JIS'97, IEC)
(Usable range: -200 to +850°C, -328 to +1562°F; min.span: 50°C, 90°F)
 - 5:** Pt 50 Ω (JIS'81)
(Usable range: -200 to +500°C, -328 to +932°F; min.span: 100°C, 180°F)
 - 6:** Ni 508.4 Ω
(Usable range: -50 to +200°C, -58 to +392°F; min.span: 30°C, 54°F)
 - 0:** Specify
- Note: Consult us for 2-wire RTD

[2] OPTIONS (multiple selections)

- Response Time (0 – 90 %)
- blank:** Standard (≤ 0.5 sec.)
- /K:** Fast Response (Approx. 25 msec.)

- Burnout
- blank:** Upscale burnout
- /BL:** Downscale burnout
- Other Options
- blank:** none
- /Q:** Option other than the above (specify the specification)

SPECIFICATIONS OF OPTION: Q

- COATING (For the detail, refer to our web site.)
- /C01:** Silicone coating
- /C02:** Polyurethane coating
- /C03:** Rubber coating

GENERAL SPECIFICATIONS

- Construction:** Terminal block
- Connection:** M3.5 screw terminals (torque 0.8 N·m)
- Screw terminal:** Nickel-plated steel
- Housing material:** Flame-resistant resin (black)
- Isolation:** Input to output
- Zero adjustment:** -1 to +1 % (front)
- Span adjustment:** 98 to 102 % (front)
- Burnout:** Upscale standard;downscale optional
- Linearization:** Standard
- Power LED:** Orange LED turns on when the power is supplied.

INPUT SPECIFICATIONS

- Maximum leadwire resistance:** 20 Ω per wire (3-wire)
- Sensing current:** 0.7 mA (Pt); 0.35 mA (Ni 508.4 Ω)

OUTPUT SPECIFICATIONS

- Output:** 4 – 20 mA DC
- Load resistance vs. supply voltage:**
Load Resistance (Ω) = (Supply Voltage (V) – 12 (V)) ÷ 0.02
(A) (including leadwire resistance)

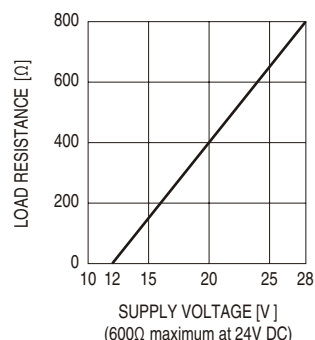

INSTALLATION

- Supply voltage:** 12 – 28 V DC
- Operating temperature:** -40 to +80°C (-40 to +176°F)

Operating humidity: 0 to 90 %RH (non-condensing)

Mounting: DIN rail

Weight: 60 g (2.1 oz)

PERFORMANCE in percentage of span

Accuracy: $\pm 0.2\%$

Temp. coefficient: $\pm 0.02\%/^{\circ}\text{C}$ ($\pm 0.01\%/^{\circ}\text{F}$)

Burnout response: ≤ 10 sec.

Insulation resistance: $\geq 100\text{ M}\Omega$ with 500 V DC

Dielectric strength: 2000 V AC @1 minute
(input to output to ground)

STANDARDS & APPROVALS

EU conformity:

EMC Directive

EMI EN 61000-6-4

EMS EN 61000-6-2

RoHS Directive

EXTERNAL VIEW

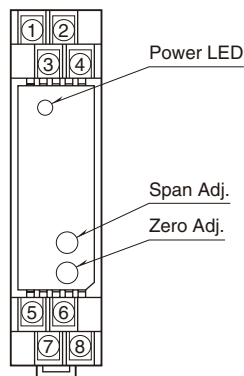

EXTERNAL DIMENSIONS & TERMINAL ASSIGNMENTS unit: mm [inch]

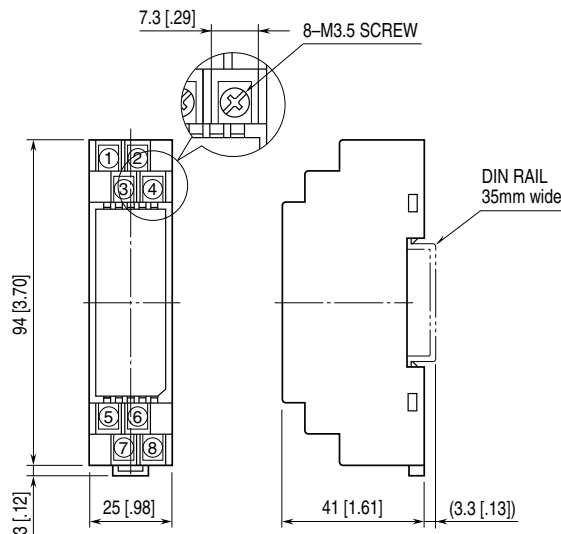

• When mounting, no extra space is needed between units.

SCHEMATIC CIRCUITRY & CONNECTION DIAGRAM

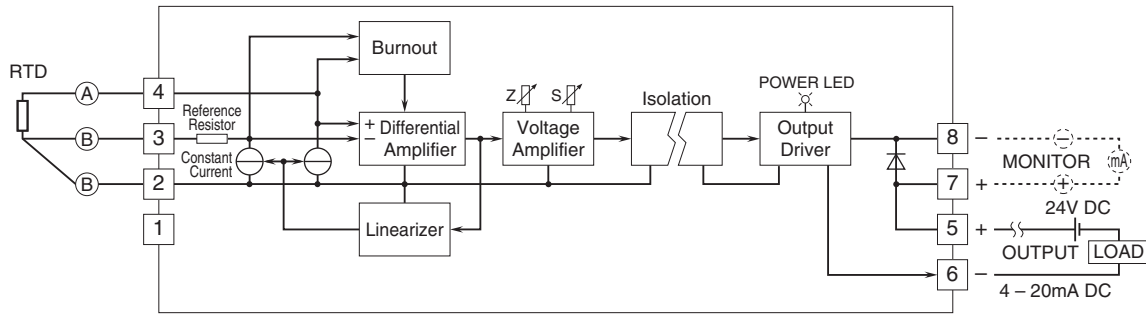

Specifications are subject to change without notice.