

**Field-mounted Two-wire Signal Conditioners
B6-UNIT SERIES**

2-WIRE UNIVERSAL TEMPERATURE TRANSMITTER

(HART communication, intrinsically safe/explosion-proof)

Functions & Features

- Universal input: mV, V, T/C, RTD, resistance and potentiometer
- High accuracy
- HART communication
- Intrinsically safe and explosion-proof approval
- Functional safety approval
- Optional stainless steel enclosure
- Programming via hand-held communicator or via PC
- A wide variety of T/C and RTD types
- User's temperature table can be used
- Self diagnostics
- Input-output isolated

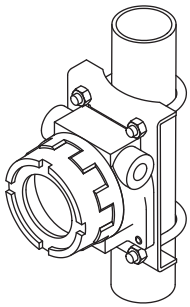

MODEL: B6U-B-[1][2][3][4][5]

ORDERING INFORMATION

- Code number: B6U-B-[1][2][3][4][5]
- Specify a code from below for each of [1] through [5].
(e.g. B6U-B-4121)
- Use Ordering Information Sheet (No. ESU-7451). Factory standard setting will be used if not otherwise specified.
- Specify the country in which the product is to be used with the Safety Approval code 2 or 4.

[1] SAFETY APPROVAL

- 0: None (functional safety not available)
- 1: FM intrinsically safe
- 2: IECEx/ATEX intrinsic safety
- 3: FM explosion-proof

4: IECEx/ATEX flameproof

5: FM nonincendive

Confirm selectable combinations of approval and wiring conduit types in the table.

[2] LCD DISPLAY

0: Without

1: With

[3] WIRING CONDUIT

0: G 1/2

1: 1/2 NPT

2: M20 × 1.5

3: PG 13.5

Confirm selectable combinations of approval and wiring conduit types in the table.

[4] MOUNTING BRACKET

0: Without

1: With

[5] OPTIONS

Enclosure Materials

Blank: Diecast aluminium enclosure

/S: Stainless steel enclosure

■ **SELECTABLE WIRING CONDUITS SPECIFIC TO EACH APPROVAL**
‘N’ marked combinations are not selectable.

WIRING CONDUIT \ APPROVAL	0	1	2	3	4	5
0	Y	N	Y	N	N	N
1	Y	Y	Y	Y	Y	Y
2	Y	Y	Y	N	Y	Y
3	Y	N	Y	N	N	N

RELATED PRODUCTS

- USB interface Bell202 modem (model: COP-HU)
Usable in ‘non-hazardous’ area only.
- Hand-held communicator
- AMS (version 6.0 or higher)
- PC configurator software (model: B6UCFG)
Downloadable at our web site.
- LCD display (model: B6U-LCD) (non safety approval)
- Lightning Surge Protectors for Electronics Equipment (Model: MD6x-24)
Refer to the specification of MD6x-24 for surge protection and safety approval.

PACKAGE INCLUDES...

- **Mounting screws**
 - Bolt (M8 x 15): 4 pcs.
 - Spring washer for M8: 4 pcs.
- Material:** Stainless steel 304
- **Mounting bracket set (option)**
 - Mounting bracket: 1 pce.
 - M10 U-bolt: 2 pcs.
 - Nut for M10: 4 pcs.
 - Spring washer for M10: 4 pcs.
- Material:** Stainless steel 304
- Applicable pipe:** 1 1/2" min.; 2" max.
- **LCD Angle Change Adaptor (for optional LCD display):**
 - Adaptor plate: 1 pce.
 - Flat head screw (M4 x 10): 2 pcs.

GENERAL SPECIFICATIONS

- Degree of protection:** NEMA 4X, IP66/IP67
Wiring conduit: See 'Ordering information.'
Electrical connection: M3.5 screw terminals (torque 0.8 N·m)
- Materials**
- Transmitter housing:** Flame-resistant resin (black)
Screw terminals: Nickel-plated brass
Enclosure: Diecast aluminium standard or stainless steel casting (equivalent to type 316); silver epoxy resin coating
Isolation: Input to output to outdoor enclosure
Burnout (T/C, RTD, Potentiometer & Resistance): Upscale, downscale or no burnout selectable (standard: upscale); Also detects wire breakdown and overrange input exceeding the electrical design limit for DC input.
Cold Junction Compensation (thermocouple input): CJC sensor incorporated
- User-configurable items:**
- Input sensor type
 - Number of wires (RTD & resistance)
 - Input range
 - Inverted output
 - Burnout
 - Damping time (via HART only, standard: 0)
 - Sensor calibration (via HART only)
 - Output calibration
 - Special linearization data (via HART only)
 - HART communication mode

HART COMMUNICATION

- Protocol:** HART communication protocol
HART address range: 0 - 15 (factory set to 0)
Transmission speed: 1200 bps
Digital current: Approx. 1 mA_{p-p} when communicating
Character format: 1 Start Bit, 8 Data Bits, 1 Odd Parity Bit,

1 Stop Bit

Distance: 1.5 km (0.9 miles)

HART communication mode: Master-Slave Mode and Burst Mode (factory set to Master-Slave)

HART network mode: Point-to-Point Mode and Multi-drop Mode; automatically set to Multi-drop Mode when the address is set to other than 0.

LCD DISPLAY (option)

Features:

- Setting and display of input signals, engineering units and the transmitter operating status, etc.
- Removable while the module is powered.

Display size: 36 × 20 mm (1.42" × 0.79")

Characters

Color: Black

Format:

- 2 rows of 5 alphanumeric characters:
 - Top row: 7.4 mm high;
 - Bottom row: 6.5 mm high,
 - Status indicators and engineering units
- For detail of the LCD panel indication, refer to the instruction manual.

Display range: -99999 to 99999

Decimal point: In top row

Read rate: 150 msec.

Back light: None

INPUT SPECIFICATIONS

The input type is factory-set to K thermocouple, and the input range to 0 to 100°C.

See Table 1 for the available input type, the minimum span, and the maximum range.

■ **DC mV & V**

Input resistance: ≥ 1 MΩ

■ **Thermocouple**

Input resistance: ≥ 1 MΩ

Burnout sensing: 130 nA ±10 %

■ **RTD (2-wire, 3-wire or 4-wire)**

Input resistance: ≥ 1 MΩ

Allowable leadwire resistance: Max. 20 Ω per wire

■ **Resistance (2-wire, 3-wire or 4-wire)**

Excitation: 0.2 mA ±10 %

Allowable leadwire resistance: Max. 20 Ω per wire

■ **Potentiometer**

Excitation: 0.2 mA ±10%

Allowable leadwire resistance: Max. 20 Ω per wire

OUTPUT SPECIFICATIONS

Output range: 4 - 20 mA DC

Operational range: 3.8 - 21.6 mA

Load resistance vs. supply voltage:

Load Resistance (Ω) = (Supply Voltage (V) - 12 (V))
 \div 0.024 (A) (including leadwire resistance)

INSTALLATION

Supply voltage

- 12 - 42 V DC (non-approved)
- 12 - 28 V DC (approved)

Operating temperature:

- Non-safety-approved unit: -40 to +85°C (-40 to +185°F)
- Safety-approved unit: See Safety Parameters for use in a hazardous location.
- LCD display (full visibility): -30 to +80°C (-22 to +176°F)

Weight:

- Unit
 - Approx. 1.3 kg (2.9 lb), aluminium
 - Approx. 4.0 kg (8.8 lb), stainless steel
- Mounting bracket set (option)
 - Approx. 0.78 kg (1.72 lb)

PERFORMANCE

Accuracy: See Table 1 and 'Explanations of Terms.'

Cold junction compensation error: $\pm 0.5^\circ\text{C}$ ($\pm 0.9^\circ\text{F}$)

Temp. coefficient: $\pm 0.015\% / ^\circ\text{C}$ ($\pm 0.008\% / ^\circ\text{F}$) of max. span at -5 to +55°C [23 to 131°F]

Start-up time: Approx. 8 sec.

Response time: ≤ 2 sec. (0 - 90 %) with damping time set to 0 and when not communicating via HART.

Supply voltage effect: $\pm 0.003\% \times [\text{Output Span}] / 1 \text{ V}$

Insulation resistance: $\geq 100 \text{ M}\Omega$ with 500 V DC

Dielectric strength: 1500 V AC @1 minute
 (input to output to outdoor enclosure)

Safety integrity level: Suitable for use in a safety instrumented system up to SIL1 or SIL2 if appropriate safety instructions are observed. Consult us.

EXPLANATIONS OF TERMS

■ ACCURACY

This transmitter's accuracy is theoretically defined as the addition of A/D and D/A conversion errors:

$$\text{Accuracy} = \text{A/D Conversion Error} + \text{D/A Conversion Error}$$

The A/D conversion error means that measured as HART signal which is A/D converted from the analog input signal. The D/A conversion error of this transmitter is relatively very small so that it does not really affect the unit's overall performance.

The "Accuracies" given in Table 1 therefore equals the A/D conversion error.

The temperature drift (coefficient) or the cold junction compensation error is not included in the "Accuracy."

■ CALCULATION EXAMPLES OF OVERALL ACCURACY IN %

• DC Voltage

1) 0 - 200 mV

Absolute value accuracy (Table 1): $40 \mu\text{V}$

$40 \mu\text{V} \div 200000 \mu\text{V} \times 100 = 0.02\% < 0.1\%$

⇒ Overall accuracy = $\pm 0.1\%$ of span

2) 0 - 4 mV

Absolute value accuracy (Table 1): $10 \mu\text{V}$

$10 \mu\text{V} \div 4000 \mu\text{V} \times 100 = 0.25\% > 0.1\%$

⇒ Overall accuracy = $\pm 0.25\%$ of span

• Thermocouple

1) K thermocouple, 0 - 1000°C

Absolute value accuracy (Table 1): 0.25°C

$0.1\% \times 1000^\circ\text{C} = 1^\circ\text{C} > 0.25^\circ\text{C}$

CJC error (0.5°C) added: $1 + 0.5 = 1.5^\circ\text{C}$

$1.5^\circ\text{C} \div 1000^\circ\text{C} \times 100 = 0.15\%$

⇒ Overall accuracy including CJC error = $\pm 0.15\%$ of span

2) K thermocouple, 50 - 150°C

Absolute value accuracy (Table 1): 0.25°C

$0.1\% \times (150 - 50)^\circ\text{C} = 0.1^\circ\text{C} < 0.25^\circ\text{C}$

CJC error (0.5°C) added: $0.25 + 0.5 = 0.75^\circ\text{C}$

$0.75^\circ\text{C} \div (150 - 50)^\circ\text{C} \times 100 = 0.75\%$

⇒ Overall accuracy including CJC error = $\pm 0.75\%$ of span

• RTD

1) Pt 100, -200 - 800°C

Absolute value accuracy (Table 1): 0.15°C

$0.15^\circ\text{C} \div (800 - -200)^\circ\text{C} \times 100 = 0.015\% < 0.1\%$

⇒ Overall accuracy = $\pm 0.1\%$ of span

2) Pt 100, 0 - 100°C

Absolute value accuracy (Table 1): 0.15°C

$0.15^\circ\text{C} \div 100^\circ\text{C} \times 100 = 0.15\% > 0.1\%$

⇒ Overall accuracy = $\pm 0.15\%$ of span

STANDARDS & APPROVALS

EU conformity:

ATEX Directive

Ex ia EN 60079-11 (for ATEX intrinsic safety)

Ex db EN 60079-1 (for ATEX flameproof)

EMC Directive

EMI EN 61000-6-4

EMS EN 61000-6-2

Immunity Test Item and Criteria

IMMUNITY TEST ITEM	STANDARD NUMBER	CRITERIA
Electrostatic discharge	EN/IEC 61000-4-2	±8kV air, ±4kV contact
Electromagnetic fields	EN/IEC 61000-4-3	10V/m at 0.08 to 1 GHz
Electrical fast transient / burst immunity	EN/IEC 61000-4-4	Signal: ±1kV
Surge	EN/IEC 61000-4-5	Signal: ±1kV line-ground
Conducted RF	EN/IEC 61000-4-6	10Vrms at 0.15 to 80 MHz

RoHS Directive

Safety approval:

FM: Intrinsically safe

Class I, Division 1, Groups A, B, C and D

Class II, Division 1, Groups E, F and G

Class III, Division 1

Class I, Zone 0, AEx ia IIC

T4, T5 and T6

(Class 3600)

(Class 3610)

(ANSI/ISA 60079-0)

(ANSI/ISA 60079-11)

FM: Explosion-proof and Dust-ignition proof

Class I, Division 1, Groups B, C and D

Class II, Division 1, Groups E, F and G

Class III, Division 1

T6

(Class 3600)

(Class 3615)

FM: Nonincendive

Class I, Division 2, Groups A, B, C, and D

Class II, Division 2, Groups F and G

Class III, Division 1

Class I, Zone 2, Group IIC

T4, T5 and T6

(Class 3600)

(Class 3611)

IECEx intrinsic safety

Ex ia IIC T4, T5 and T6 Ga

(IEC 60079-0)

(IEC 60079-11)

IECEx flameproof

Ex db IIC T4, T5 and T6 Gb

(IEC 60079-0)

(IEC 60079-1)

KOSHA: flameproof (Occupational Safety and Health Act)

Ex d IIC T6

(Only available for Model: B6U-B-41****)

ATEX Intrinsic safety

Ⓔ II 1G, Ex ia IIC, T4, T5 and T6 Ga

(EN 60079-0)

(EN 60079-11)

ATEX Flameproof

Ⓔ II 2G, Ex db IIC, T4, T5 and T6 Gb

(EN 60079-0)

(EN 60079-1)

Functional safety

(SIL 1 @ IEC 61508-1, -2)

(SIL 2 @ IEC 61511-1)

* Safety approval code "0" is not applicable.

SAFETY PARAMETERS

Operating temperature

For IECEx, ATEX and FM:

T4: -40 to +80°C

T5: -40 to +65°C

T6: -40 to +50°C (-40 to +80°C for FM explosion-proof)

Ex-data:

- Output circuit

Ui (Vmax): 30 V

Ii (Imax): 96 mA

Pi (Pmax): 720 mW

Ci: 0 µF

Li: 0 mH

- Sensor circuit

Uo (Voc): 6.4 V

Io (Isc): 30 mA

Po: 48 mW

Co (Ca): 20 µF

Lo (La): 10 mH

INPUT TYPE, RANGE & ACCURACY

■ INPUT TYPE, RANGE & ACCURACY

Table 1

INPUT TYPE	MIN. SPAN	MAXIMUM RANGE		ACCURACY				
DC mV & V	4 mV	-50 to +1000 mV		±0.1 % or ±10μV, whichever is greater (F.S. input 50 mV) ±0.1 % or ±40μV, whichever is greater (F.S. input 200 mV) ±0.1 % or ±60μV, whichever is greater (F.S. input 500 mV) ±0.1 % or ±80μV, whichever is greater (F.S. input >500 mV)				
Potentiometer	2%	Total resistance 80 to 4000Ω		±0.1 %				
Resistance	10Ω	0 to 4000Ω		±0.1 % or ±0.1Ω, whichever is greater.*2				
THERMOCOUPLE	°C				°F			
	MIN. SPAN	MAXIMUM RANGE	CONFORMANCE RANGE	ACCURACY *1	MIN. SPAN	MAXIMUM RANGE	CONFORMANCE RANGE	ACCURACY *1
(PR)	20	0 to 1760	0 to 1760	±1.00	36	32 to 3200	32 to 3200	±1.80
K (CA)	20	-270 to +1370	-150 to +1370	±0.25	36	-454 to +2498	-238 to +2498	±0.45
E (CRC)	20	-270 to +1000	-170 to +1000	±0.20	36	-454 to +1832	-274 to +1832	±0.36
J (IC)	20	-210 to +1200	-180 to +1200	±0.25	36	-346 to +2192	-292 to +2192	±0.45
T (CC)	20	-270 to +400	-170 to +400	±0.25	36	-454 to +752	-274 to +752	±0.45
B (RH)	20	100 to 1820	400 to 1760	±0.75	36	212 to 3308	752 to 3200	±1.35
R	20	-50 to +1760	200 to 1760	±0.50	36	-58 to +3200	392 to 3200	±0.90
S	20	-50 to +1760	0 to 1760	±0.50	36	-58 to +3200	32 to 3200	±0.90
C (WRe 5-26)	20	0 to 2315	0 to 2315	±0.25	36	32 to 4199	32 to 4199	±0.45
N	20	-270 to +1300	-130 to +1300	±0.30	36	-454 to +2372	-202 to +2372	±0.54
U	20	-200 to +600	-200 to +600	±0.20	36	-328 to +1112	-328 to +1112	±0.36
L	20	-200 to +900	-200 to +900	±0.25	36	-328 to +1652	-328 to +1652	±0.45
P (Platinel II)	20	0 to 1395	0 to 1395	±0.25	36	32 to 2543	32 to 2543	±0.45
RTD	°C				°F			
	MIN. SPAN	MAXIMUM RANGE		ACCURACY *2	MIN. SPAN	MAXIMUM RANGE		ACCURACY *2
Pt 100 (JIS '97, IEC)	20	-200 to +850		±0.15	36	-328 to +1562		±0.27
Pt 200	20	-200 to +850		±0.15	36	-328 to +1562		±0.27
Pt 300	20	-200 to +850		±0.15	36	-328 to +1562		±0.27
Pt 400	20	-200 to +850		±0.15	36	-328 to +1562		±0.27
Pt 500	20	-200 to +850		±0.15	36	-328 to +1562		±0.27
Pt 1000	20	-200 to +850		±0.15	36	-328 to +1562		±0.27
Pt 50 Ω (JIS '81)	20	-200 to +649		±0.15	36	-328 to +1200		±0.27
JPt 100 (JIS '89)	20	-200 to +510		±0.15	36	-328 to +950		±0.27
Ni 100	20	-80 to +260		±0.15	36	-112 to +500		±0.27
Ni 120	20	-80 to +260		±0.15	36	-112 to +500		±0.27
Ni 508.4 Ω	20	-50 to +200		±0.15	36	-58 to +392		±0.27
Ni-Fe 604	20	-200 to +200		±0.15	36	-328 to +392		±0.27
Cu 10 @25°C	20	-50 to +250		±0.50	36	-58 to +482		±0.90

*1. [Accuracy or ±0.1 % of span, whichever is greater] + Cold Junction Compensation Error

*2. Or ±0.1% of span, whichever is greater.

(For 2- or 3-wire resistance or RTD, the value is valid by the sensor calibration after the wiring is done.)

EXTERNAL DIMENSIONS unit: mm [inch]

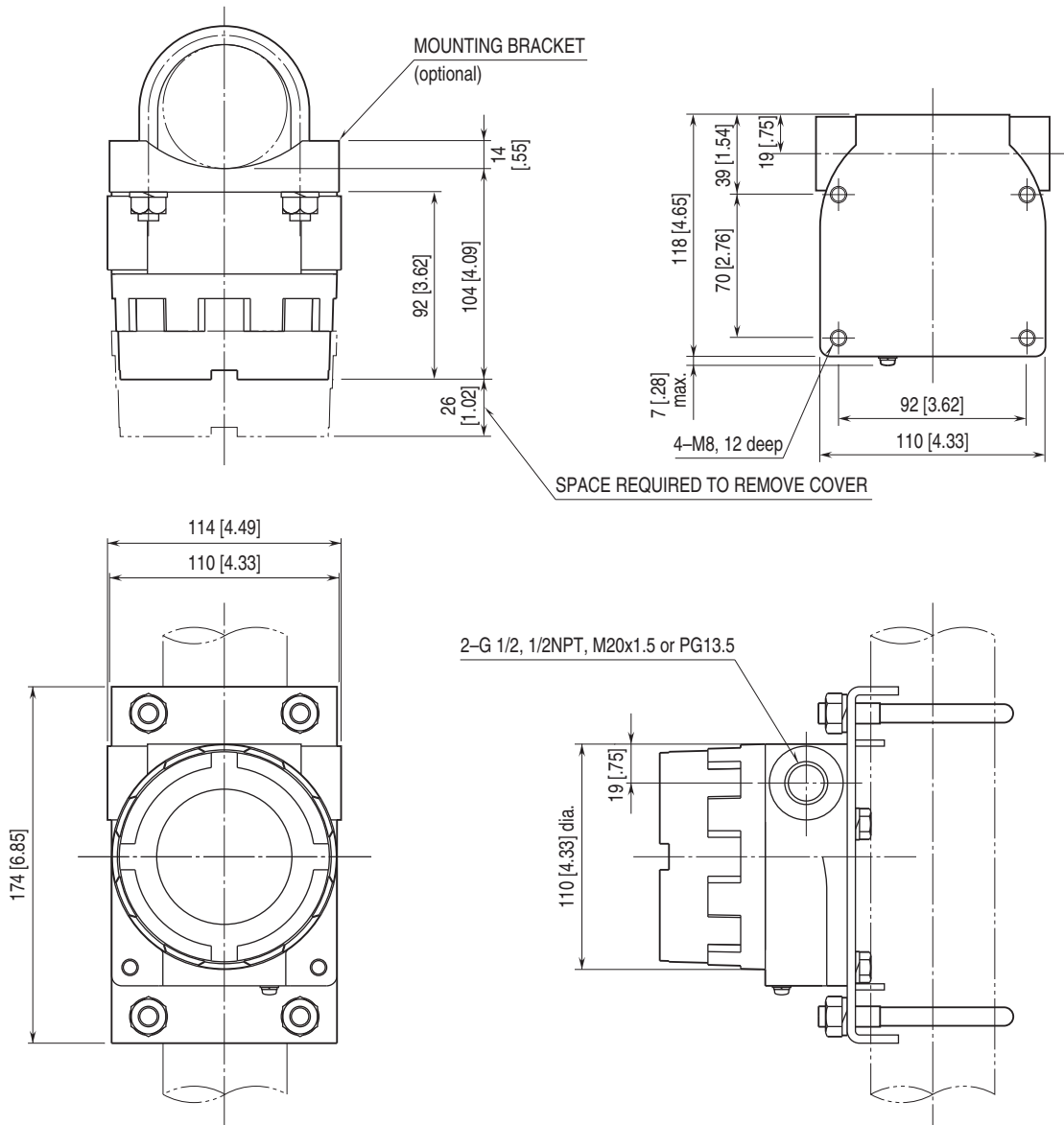

SCHEMATIC CIRCUITRY & CONNECTION DIAGRAM

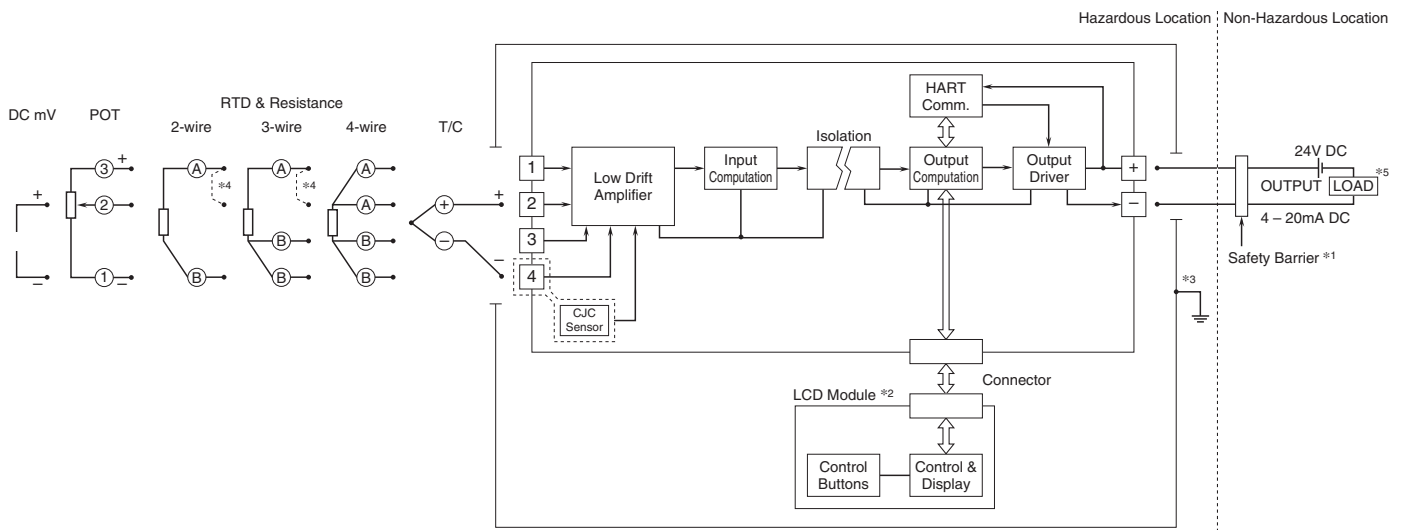

- *1. A safety barrier must be installed for the intrinsic safety.
The safety barrier must meet the Ex-data of this unit and must be approved for the hazardous location.
- *2. Optional
- *3. Be sure to earth the unit's enclosure to meet the intrinsically safe or explosion-proof (flameproof) requirements.
- *4. Close across the terminals 1 & 2 for a resistance or RTD input.
- *5. Limited to 250 – 1100Ω for HART communication.



Specifications are subject to change without notice.