

Plug-in Signal Conditioners M-UNIT

COMPUTER BACKUP STATION

Functions & Features

- Holding and manipulating control signals in case of computer or DCS failure
- Ramp rate adjustable
- High-density mounting

Typical Applications

- Computer and DCS backup applications
- Used as manual-auto controller

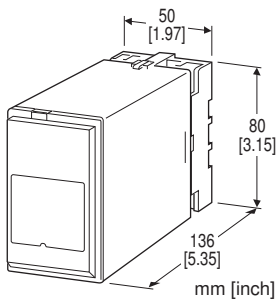

MODEL: CB2-[1]-[2][3]

ORDERING INFORMATION

- Code number: CB2-[1]-[2][3]

Specify a code from below for each of [1] through [3].
(e.g. CB2-A-B/Q)

- Special output range (For codes Z & 0)
- Specify the specification for option code /Q
(e.g. /C01/S01)

[1] OUTPUT

Current

- A:** 4 - 20 mA DC (Load resistance 750 Ω max.)
- B:** 2 - 10 mA DC (Load resistance 1500 Ω max.)
- C:** 1 - 5 mA DC (Load resistance 3000 Ω max.)
- D:** 0 - 20 mA DC (Load resistance 750 Ω max.)
- E:** 0 - 16 mA DC (Load resistance 900 Ω max.)
- F:** 0 - 10 mA DC (Load resistance 1500 Ω max.)
- G:** 0 - 1 mA DC (Load resistance 15 kΩ max.)
- Z:** Specify current (See OUTPUT SPECIFICATIONS)

Voltage

- 1:** 0 - 10 mV DC (Load resistance 10 kΩ min.)
- 2:** 0 - 100 mV DC (Load resistance 100 kΩ min.)
- 3:** 0 - 1 V DC (Load resistance 100 Ω min.)
- 4:** 0 - 10 V DC (Load resistance 1000 Ω min.)
- 5:** 0 - 5 V DC (Load resistance 500 Ω min.)
- 6:** 1 - 5 V DC (Load resistance 500 Ω min.)

4W: -10 - +10 V DC (Load resistance 2000 Ω min.)

0: Specify voltage (See OUTPUT SPECIFICATIONS)

[2] POWER INPUT

AC Power

B: 100 V AC

C: 110 V AC

D: 115 V AC

F: 120 V AC

G: 200 V AC

H: 220 V AC

J: 240 V AC

DC Power

S: 12 V DC

R: 24 V DC

[3] OPTIONS

blank: none

/Q: With options (specify the specification)

SPECIFICATIONS OF OPTION: Q (multiple selections)

COATING (For the detail, refer to our web site.)

/C01: Silicone coating

/C02: Polyurethane coating

/C03: Rubber coating

TERMINAL SCREW MATERIAL

/S01: Stainless steel

RELATED PRODUCTS

- Soft-Terminal (model: ST/STL)

GENERAL SPECIFICATIONS

Construction: Plug-in

Connection: M3.5 screw terminals

Screw terminal: Chromated steel (standard) or stainless steel

Housing material: Flame-resistant resin (black)

Isolation: Input to output to power

Overrange output: 0 to 100 %

Ramp rate adjustment: Approx. 5 - 30 sec. (front)

Zero adjustment: -5 to +5 % (front)

Span adjustment: 95 to 105 % (front)

INPUT SPECIFICATIONS

■ **Contact Input:** TTL level (5V-CMOS level) or open collector/dry contact (saturation voltage ≤ 1 V, sink current 0.5 mA)

- **Input signal from the computer**

UP: The output increases with UP signal ON.

DOWN: The output decreases with DOWN signal

ON.

STOP: The CB2 tracks the computer input with the STOP signal ON; holds the value just before the OFF signal with OFF.

• **Soft-terminal input in manual mode**

UP: The output increases with UP signal ON.

DOWN: The output decreases with DOWN signal ON.

OUTPUT SPECIFICATIONS

■ **DC Current:** 0 - 20 mA DC

Minimum span: 1 mA

Offset: Max. 1.5 times span

Load resistance: Output drive 15 V max.

■ **DC Voltage:** -10 - +12 V DC

Minimum span: 5 mV

Offset: Max. 1.5 times span

Load resistance: Output drive 10 mA max.; 5 mA for negative voltage output; at ≥ 0.5 V

INSTALLATION

Power input

• **AC:** Rating ± 10 %, 50/60 ± 2 Hz,

approx. 5 VA at 100 V

approx. 7 VA at 200 V

approx. 10 VA at 240 V

• **DC:** Rating ± 10 % (ripple 10 %p-p max.) approx. 3.5 W
(150 mA at 24 V)

Operating temperature: -5 to +55°C (23 to 131°F)

Operating humidity: 30 to 90 %RH (non-condensing)

Mounting: Surface or DIN rail

Weight: 450 g (0.99 lb)

PERFORMANCE in percentage of span

Temp. coefficient: ± 0.02 %/°C (± 0.01 %/°F)

Response time: Approx. 5 - 30 sec. variable (0 - 100 %)

Output memory at power failure: The output value is stored in memory.

Line voltage effect: ± 0.1 % over voltage range

Insulation resistance: ≥ 100 M Ω with 500 V DC

Dielectric strength: 1000 V AC @1 minute

(input to output to power)

2000 V AC @1 minute

(input or output or power to ground)

CONNECTION EXAMPLES

■CB2 Used Independently

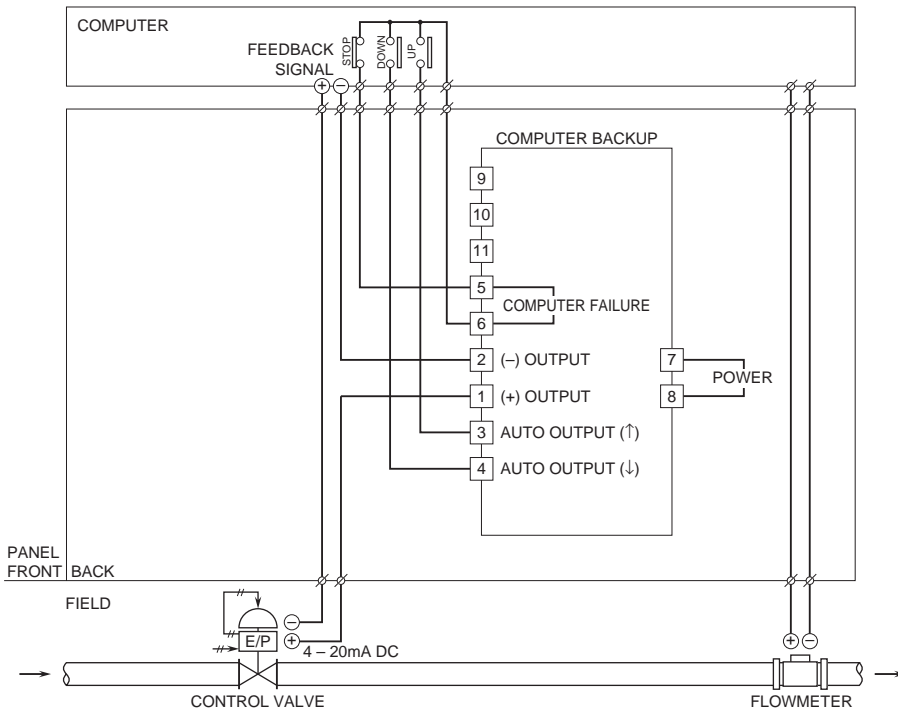

■CB2 Used in Combination with ST/STL

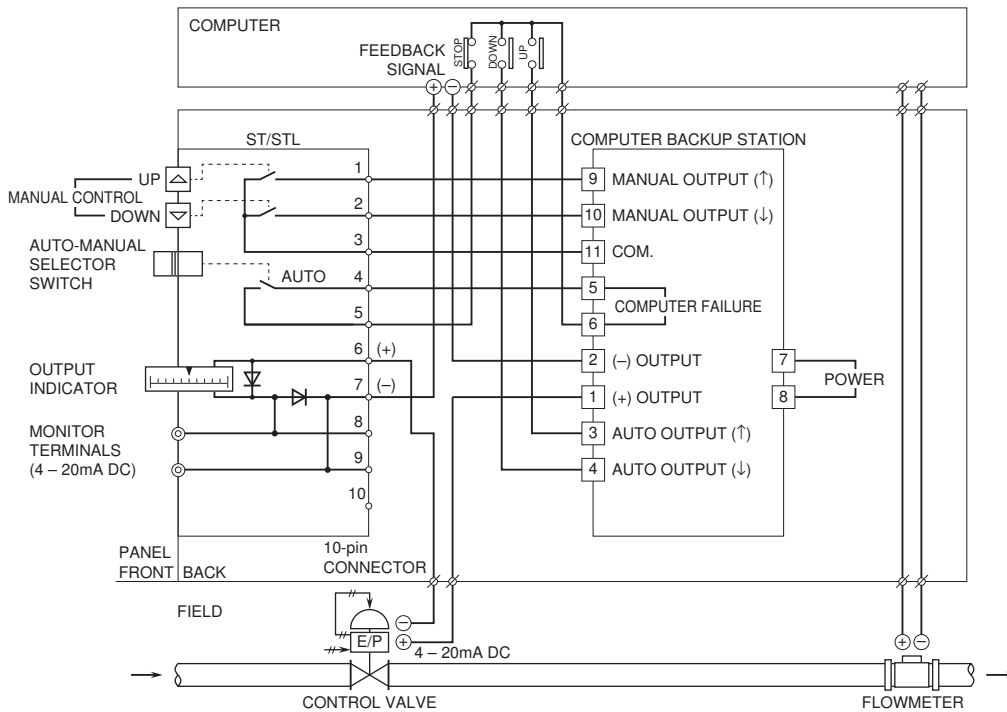

EXTERNAL DIMENSIONS & TERMINAL ASSIGNMENTS unit: mm [inch]

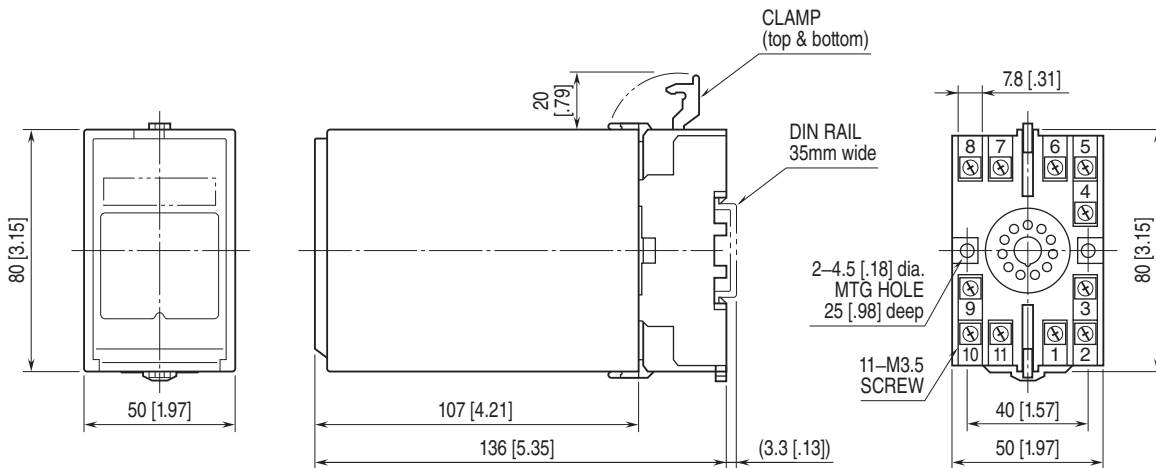

• When mounting, no extra space is needed between units.

SCHEMATIC CIRCUITRY & CONNECTION DIAGRAM

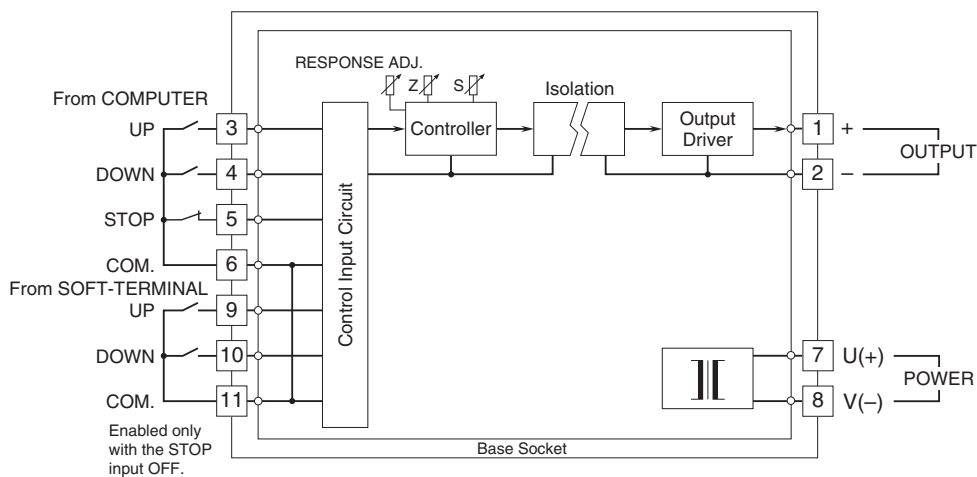

OPERATION

■ CB2 Used Independently

In normal operating mode, the CB2 responds to UP/DOWN signals from the computer in the preset ramp rate.

If the computer fails, this will be detected as a "STOP" command and output will be held at the value prior to the breakdown.

You can increase the output signal by closing across the terminals 9 - 11, and decrease it by closing 10 - 11. The output responds in the preset ramp rate.

■ CB2 Used in Combination with ST/STL

In normal operating mode, the CB2 responds to UP/DOWN signals from the computer in the preset ramp rate.

If the computer fails, the "STOP" command will override computer output and put the unit in the manual operation mode by the ST/STL. Using the top-mounted UP-DOWN buttons, output can be increased or decreased in the preset ramp rate. Output signal value can be read on the top-mounted indicator. For more precise control, use the monitor terminals.

Also the computer input can be overridden with the AUTO-MANUAL selector on the Soft-Terminal. This is useful when you need to change the output quickly during automatic operation by the computer control.

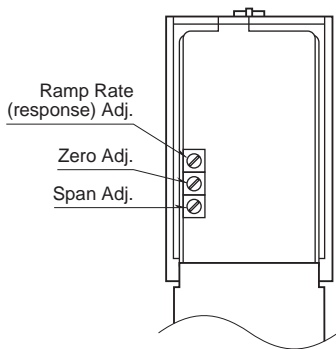

	COMMAND	TERM.	SIGNAL STATUS
Computer	UP	3-6	1 0 0 1 - - - -
	DOWN	4-6	0 1 0 1 - - - -
	STOP	5-6	1 1 1 1 0 0 0 0
ST/STL	UP	9-11	- - - - 1 0 0 1
	DOWN	10-11	- - - - 0 1 0 1
Output of the CB2		1-2	↑ ↓ H H ↑ ↓ H H

[Keys] 1 : ON 0 : OFF - : ON or OFF
 H : Hold ↑ : Increase ↓ : Decrease

SYSTEM CONFIGURATION EXAMPLES

- Analog Control Using Contact Closure Outputs from a Computer
- CB2 Used Independently •CB2 – ST/STL Combination

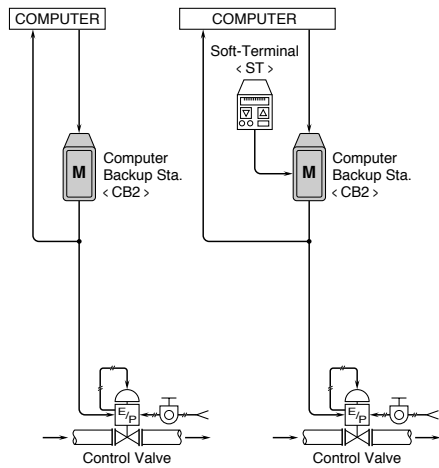

- Employing an Analog Controller in a DDC Control Loop
- CB2 – ST/STL Combination

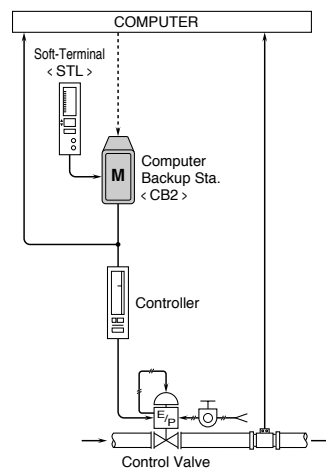

- Control Loop with Multiplex Transmission

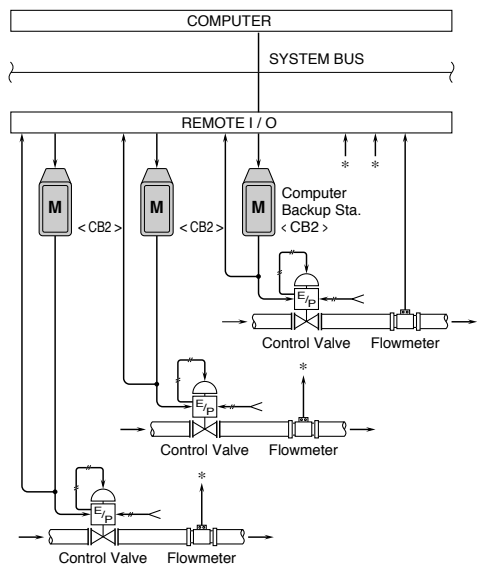

- Remote Control of an I/O Positioner with Switches

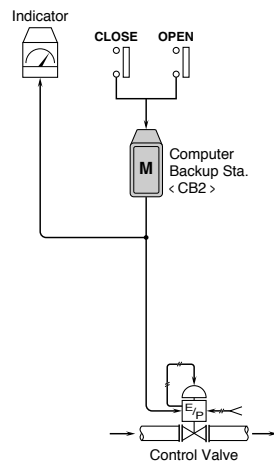



Specifications are subject to change without notice.