

**Plug-in Signal Conditioners M-UNIT**

**SIGNAL TRANSMITTER**

(CE, non-isolated)

**Functions & Features**

- Converting a DC input into a standard process signal
- High-density mounting

**Typical Applications**

- mV, voltage and current scaling
- Buffer on a standard process signal line in order to increase load allowance (plus 500 Ω with 4 - 20 mA)

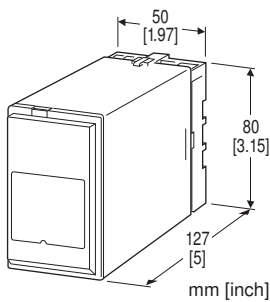

**MODEL: CV-[1][2]-[3][4]**

**ORDERING INFORMATION**

- Code number: CV-[1][2]-[3][4]
- Specify a code from below for each of [1] through [4]. (e.g. CV-6A-B/CE/Q)
- Special input and output ranges (For codes Z & 0)
- Specify the specification for option code /Q (e.g. /C01/S01)

**[1] INPUT**

Current

- A:** 4 - 20 mA DC (Input resistance 250 Ω)
- A1:** 4 - 20 mA DC (Input resistance 50 Ω)
- B:** 2 - 10 mA DC (Input resistance 500 Ω)
- C:** 1 - 5 mA DC (Input resistance 1000 Ω)
- D:** 0 - 20 mA DC (Input resistance 50 Ω)
- E:** 0 - 16 mA DC (Input resistance 62.5 Ω)
- F:** 0 - 10 mA DC (Input resistance 100 Ω)
- G:** 0 - 1 mA DC (Input resistance 1000 Ω)
- H:** 10 - 50 mA DC (Input resistance 100 Ω)
- J:** 0 - 10 μA DC (Input resistance 1000 Ω)
- K:** 0 - 100 μA DC (Input resistance 1000 Ω)
- GW:** -1 - +1 mA DC (Input resistance 1000 Ω)
- FW:** -10 - +10 mA DC (Input resistance 100 Ω)
- Z:** Specify current (See INPUT SPECIFICATIONS)

Voltage

- 1:** 0 - 10 mV DC (Input resistance 10 kΩ min.)
- 15:** 0 - 50 mV DC (Input resistance 10 kΩ min.)
- 16:** 0 - 60 mV DC (Input resistance 10 kΩ min.)
- 2:** 0 - 100 mV DC (Input resistance 100 kΩ min.)
- 3:** 0 - 1 V DC (Input resistance 1 MΩ min.)
- 4:** 0 - 10 V DC (Input resistance 1 MΩ min.)
- 5:** 0 - 5 V DC (Input resistance 1 MΩ min.)
- 6:** 1 - 5 V DC (Input resistance 1 MΩ min.)
- 4W:** -10 - +10 V DC (Input resistance 1 MΩ min.)
- 5W:** -5 - +5 V DC (Input resistance 1 MΩ min.)
- 0:** Specify voltage (See INPUT SPECIFICATIONS)

**[2] OUTPUT**

Current

- A:** 4 - 20 mA DC (Load resistance 750 Ω max.)
- B:** 2 - 10 mA DC (Load resistance 1500 Ω max.)
- C:** 1 - 5 mA DC (Load resistance 3000 Ω max.)
- D:** 0 - 20 mA DC (Load resistance 750 Ω max.)
- E:** 0 - 16 mA DC (Load resistance 900 Ω max.)
- F:** 0 - 10 mA DC (Load resistance 1500 Ω max.)
- G:** 0 - 1 mA DC (Load resistance 15 kΩ max.)
- Z:** Specify current (See OUTPUT SPECIFICATIONS)

Voltage

- 1:** 0 - 10 mV DC (Load resistance 10 kΩ min.)
- 2:** 0 - 100 mV DC (Load resistance 100 kΩ min.)
- 3:** 0 - 1 V DC (Load resistance 3000 Ω min.)
- 4:** 0 - 10 V DC (Load resistance 10 kΩ min.)
- 5:** 0 - 5 V DC (Load resistance 5000 Ω min.)
- 6:** 1 - 5 V DC (Load resistance 5000 Ω min.)
- 4W:** -10 - +10 V DC (Load resistance 20 kΩ min.)
- 5W:** -5 - +5 V DC (Load resistance 10 kΩ min.)
- 0:** Specify voltage (See OUTPUT SPECIFICATIONS)

**[3] POWER INPUT**

AC Power

- B:** 100 V AC
- C:** 110 V AC
- D:** 115 V AC
- F:** 120 V AC
- G:** 200 V AC
- H:** 220 V AC
- J:** 240 V AC

DC Power

- S:** 12 V DC
- R:** 24 V DC
- V:** 48 V DC

**[4] OPTIONS (multiple selections)**

- Standards & Approvals (must be specified)
- /CE: CE marking

## Other Options

**blank:** none

**/Q:** Option other than the above (specify the specification)

## SPECIFICATIONS OF OPTION: Q (multiple selections)

**COATING** (For the detail, refer to our web site.)

**/C01:** Silicone coating

**/C02:** Polyurethane coating

**/C03:** Rubber coating

**TERMINAL SCREW MATERIAL**

**/S01:** Stainless steel

## GENERAL SPECIFICATIONS

**Construction:** Plug-in

**Connection:** M3.5 screw terminals

**Screw terminal:** Chromated steel (standard) or stainless steel

**Housing material:** Flame-resistant resin (black)

**Isolation:** Input or output to power

**Overrange output:** Approx. -10 to +120 % at 1 - 5 V

**Zero adjustment:** -5 to +5 % (front)

**Span adjustment:** 95 to 105 % (front)

## INPUT SPECIFICATIONS

### ■ DC Current:

Shunt resistor attached to the input terminals (0.5 W)

Specify input resistance value for code Z.

### ■ DC Voltage: -30 - +30 V DC

**Span:** Min. 3 mV, max. 30 V

**Offset:** Max. 1.5 times span

### Input resistance

Span 3 - 10 mV :  $\geq 10 \text{ k}\Omega$

Span 10 - 100 mV :  $\geq 10 \text{ k}\Omega$

Span 0.1 - 1 V :  $\geq 100 \text{ k}\Omega$

Span  $\geq 1 \text{ V}$  :  $\geq 1 \text{ M}\Omega$

## OUTPUT SPECIFICATIONS

### ■ DC Current: 0 - 20 mA DC

**Minimum span:** 1 mA

**Offset:** Max. 1.5 times span

**Load resistance:** Output drive 15 V max.

### ■ DC Voltage: -10 - +12 V DC

**Minimum span:** 5 mV

**Offset:** Max. 1.5 times span

**Load resistance:** Output drive 1 mA max. at  $\geq 3 \text{ V}$

## INSTALLATION

### Power input

• **AC:** Operational voltage range: rating  $\pm 10 \%$ , 50/60  $\pm 2 \text{ Hz}$ , approx. 2 VA

• **DC:** Operational voltage range: rating  $\pm 10 \%$ ,

ripple 10 %p-p max., approx. 2 W (80 mA at 24 V)

**Operating temperature:** -5 to +60°C (23 to 140°F)

**Operating humidity:** 30 to 90 %RH (non-condensing)

**Mounting:** Surface or DIN rail

**Weight:** 300 g (0.66 lb)

## PERFORMANCE in percentage of span

**Accuracy:**  $\pm 0.1 \%$

**Temp. coefficient:**  $\pm 0.015 \%/^{\circ}\text{C}$  ( $\pm 0.008 \%/^{\circ}\text{F}$ )

**Response time:**  $\leq 0.5 \text{ sec.}$  (0 - 90 %)

**Line voltage effect:**  $\pm 0.1 \%$  over voltage range

**Insulation resistance:**  $\geq 100 \text{ M}\Omega$  with 500 V DC

**Dielectric strength:** 2300 V AC @1 minute

(input or output to power to ground)

## STANDARDS & APPROVALS

### EU conformity:

EMC Directive

EMI EN 61000-6-4

EMS EN 61000-6-2

Low Voltage Directive

EN 61010-1

Installation Category II

Pollution Degree 2

Input or output to power: Reinforced insulation (300 V)

RoHS Directive

## EXTERNAL DIMENSIONS unit: mm [inch]

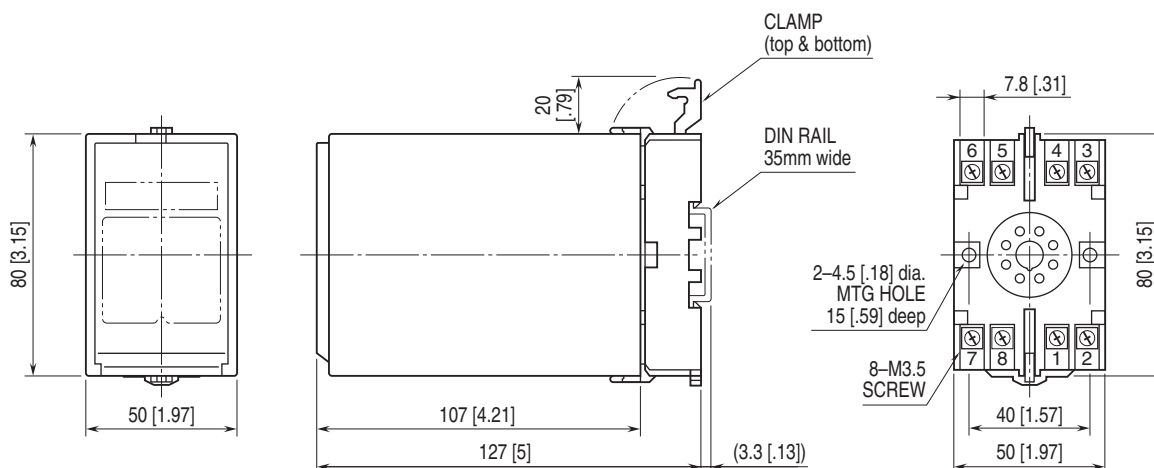

• When mounting, no extra space is needed between units.

## TERMINAL ASSIGNMENTS unit: mm [inch]

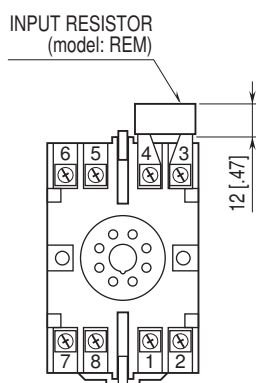

Input shunt resistor attached for current input.

## SCHEMATIC CIRCUITRY & CONNECTION DIAGRAM

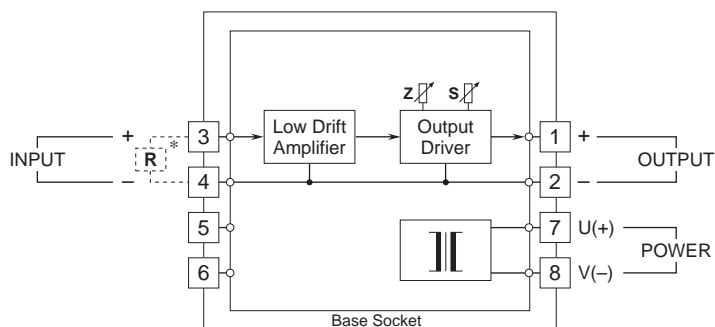

\*Input shunt resistor attached for current input.



Specifications are subject to change without notice.