

Communication Adaptor GR8 Series

Ethernet/RS-485 Adaptor

(Modbus use)

Functions & Features

- Bidirectional protocol converter for Modbus/TCP (Ethernet) and Modbus RTU (RS-485)
- Fast response time thanks to the Cache function
- Available the type designed to connect to DL8 and R8 series modules

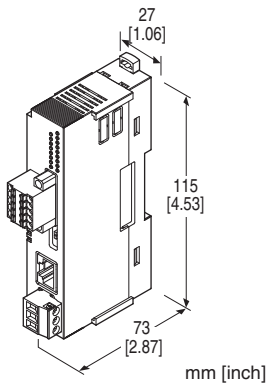

MODEL: GR8-EM-[1]-[2]

ORDERING INFORMATION

- Code number: GR8-EM-[1]-[2]
- Specify a code from below for each of [1] and [2].
(e.g. GR8-EM-D-R)

[1] INSTALLATION

- S: Single Use
 - D: Coupled with DL8
- * The internal bus of DL8 is not connected although coupled with DL8.

[2] POWER INPUT

- AC Power**
- M2: 100 - 240 V AC, 50 - 60 Hz
(Operational voltage range 85 - 264 V, 47 - 66 Hz)
- DC Power**
- R: 24 V DC
(Operational voltage range 24 V ±10 %, ripple 10 %p-p max.)

GENERAL SPECIFICATIONS

Connection

- Power input: Euro type connector terminal
- Applicable wire size:** 0.2 - 2.5 mm²
Stripped length: 7 mm

- RS-485:** Tension clamp (Front Twin connection)
Applicable wire size: 0.2 - 1.5 mm²
Stripped length: 10 mm
- Ethernet:** RJ-45 connector
- Housing material:** Flame-resistant resin (black)
- Isolation:** Ethernet to RS-485 to power supply to FE1
- DIP SW Setting:** Selection of IP Address and Maintenance/Normal mode
- Configurator (IP Address and baud rate)
Settings from Web browser (provided by user)
Compatible terminal, browser
Windows PC (Windows 7, 8.1, 10):
Internet Explorer 11.0.47
Firefox 62.0.3
Chrome 69.0.3497.100
Edge 44.17763.1.0
Smart Phone, Tablet PC (iOS 11.4.1, Android 8.0.0)
Safari 11.4.1
Chrome 69.0.3497.100
- Status indicator LED:** RUN, ERR, RD, SD, LINK, LK100

■ Modbus RTU

•Supported Commands

- Read Coil Status (01)
- Read Input Status (02)
- Read Holding Registers (03)
- Read Input Registers (04)
- Force Single Coil (05)
- Preset Single Register (06)
- Diagnostics (08)
- Fetch Comm. Event Counter (11)
- Fetch Comm. Event Log (12)
- Force Multiple Coils (15)
- Preset Multiple Registers (16)
- Report Slave ID (17)

■ Cache Commands

- Following commands are valid for Cache function.
- Read Coil Status (01)
 - Read Input Status (02)
 - Read Holding Registers (03)
 - Read Input Registers (04)
- (Up to 100 queries)

Ethernet, Modbus/TCP

Standard: IEEE 802.3u

Transmission type: 10BASE-T, 100BASE-TX

Transmission speed: 10 / 100M bps

(Auto Negotiation)

Protocol: TCP/IP

Number of connections: 8

Transmission media:

10BASE-T (STP cable; Category 5)

100BASE-TX (STP cable; Category 5e)

Maximum segment length: 100 meters

Communication configuration: with Web browser

IP address: 192.168.0.1 (factory default setting)

Subnet mask

Default gateway

Port No.: 502 (factory default setting)

User name, password

Modbus exception response

Connection time out

PERFORMANCE

Insulation resistance: $\geq 100 \text{ M}\Omega$ with 500 V DC

Dielectric strength: 1500 V AC @ 1 minute (Ethernet to RS-485 to power to FE1)

STANDARDS & APPROVALS

EU conformity:

EMC Directive

EMI EN 61000-6-4

EMS EN 61000-6-2

Low Voltage Directive

EN 61010-1, EN 61010-2-201

Installation Category II (power input)

Pollution Degree 2

Modbus to power: Reinforced insulation (300 V)

RoHS Directive

RS-485, Modbus-RTU

Protocol: Modbus RTU

Configuration: Bus type multi-drop

Standard: Conforms to TIA/EIA-485-A

Communication: Half-duplex, asynchronous, no procedure

Transmission media: Shielded twisted-pair cable (CPEV-S 0.9 dia.)

Communication configuration: with Web browser

Baud rate: 2.4, 4.8, 9.6, 19.2, 38.4(*), 57.6, 115.2 kbps

Parity bit: None, Odd(*), Even

Stop bit: 1(*), 2

Read response timeout: 1000 msec.(*), 10 - 10 000 msec.

Write response timeout: 1000 msec.(*), 10 - 10 000 msec.

Cache function: Enabled(*), disabled

Inter-frame interval: 10 msec.(*), 0 - 500 msec.

(*Factory default setting

Terminating resistor: Built-in 110 Ω (DIP Switch, default: enabled)

INSTALLATION

Power consumption

•AC:

Max. 3.5 VA at 100 V

Max. 4.5 VA at 200 V

Max. 5.5 VA at 264 V

•DC: $\leq 1.5 \text{ W}$

Operating temperature: -10 to +55°C (14 to 131°F)

Operating humidity: 10 to 90 %RH (non-condensing)

Mounting: DIN rail

Weight: 120 g (0.26 lb)

BASIC CONFIGURATIONS

■ COUPLED WITH DL8

Make sure to install the unit coupled with DL8 at the end of all the other modules. With the unit installed between DL8 and I/O modules, I/O modules after the unit can not perform internal communication or the power can not be supplied to these I/O modules.

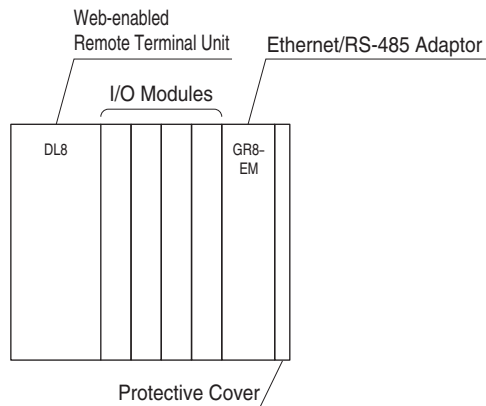

• HOW TO INSTALL

Confirm that the locking clamps of the unit are set. Insert the unit straight in perpendicularly to the rail such that the grooves of the unit and the module on the immediate left engage each other. (A & B in the below figure)

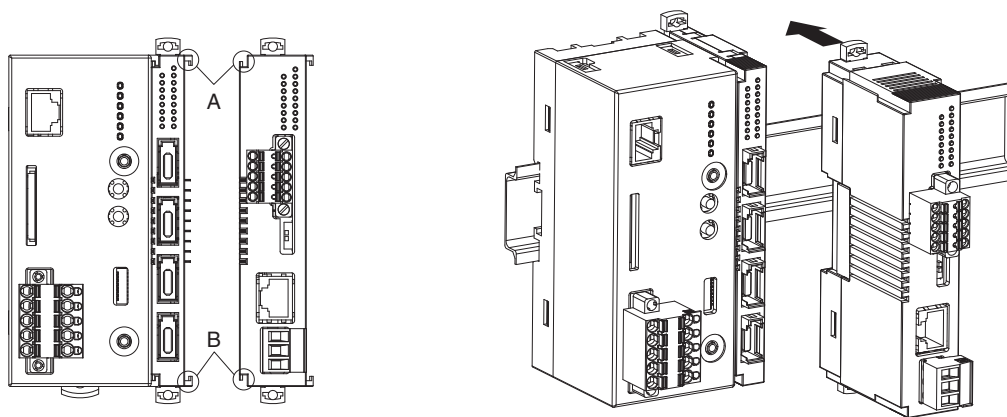

■ SINGLE USE

• HOW TO INSTALL

A) Hang the upper hook at the rear side of unit on the DIN rail. Push in the lower in keeping pressing the unit to the DIN rail.

B) To remove the unit, push down the DIN rail adaptor using a minus screwdriver. Pull out the lower part of the unit.

Remove the upper part from the DIN rail.

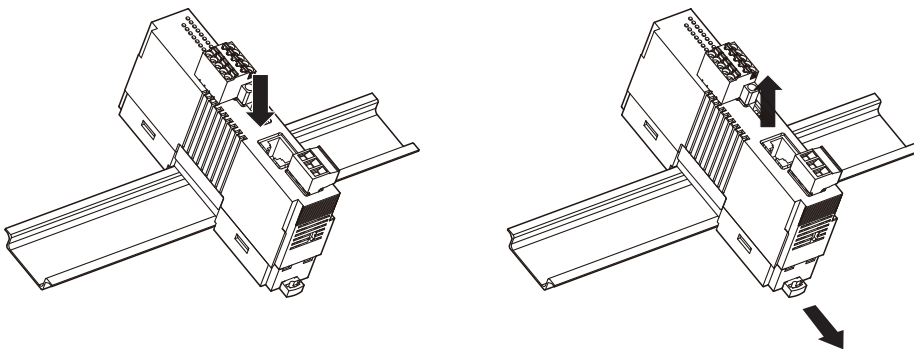

Note: When the unit is mounted on a DIN rail attached on the wall surface in vertical direction, use of an attachment plate to prevent the module from sliding down is recommended.

EXTERNAL VIEW

FRONT VIEW

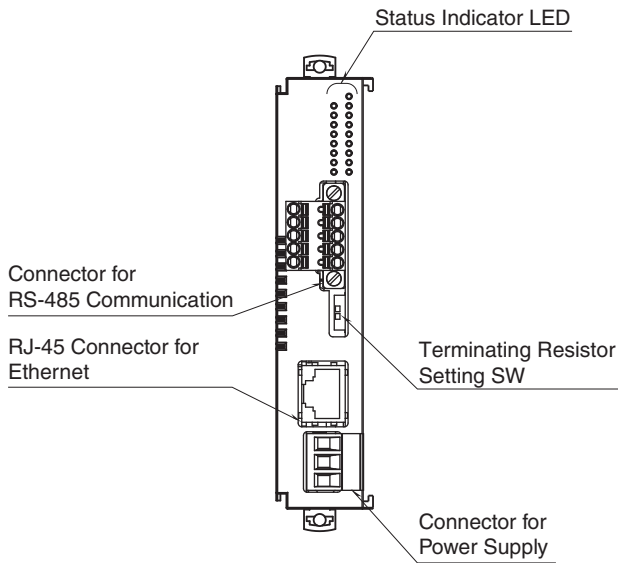

RIGHT SIDE VIEW

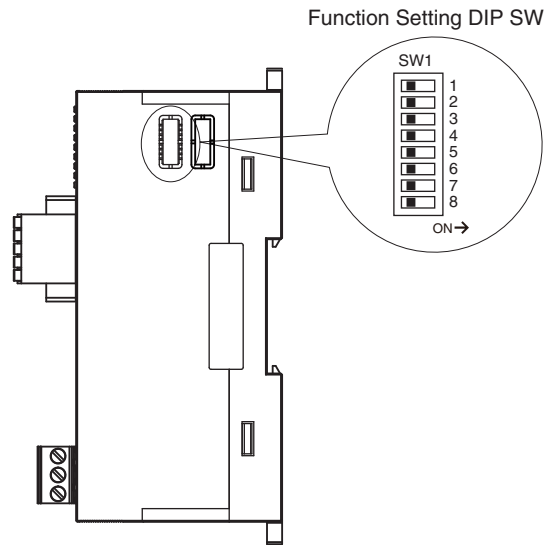

STATUS INDICATOR LED

LED	Color	Light	Module Status
RUN	Green	Blinking (1-sec cycle)	Normal mode
		Blinking in low speed (2-sec cycle)	Maintenance mode (with SW1-2 ON)
		Blinking in high speed (0.4-sec cycle)	Error (device error when the unit wouldn't recover even after power reactivation)
		OFF	Power is off or device error
ERR	Red	ON	Data error from RS-485 device
RD	Green	ON	Receiving data from the paired RS-485 station
SD	Green	ON	Sending data to the paired RS-485 station
LINK	Green	ON	Being linked with 10BASE or 100BASE
		Blinking	Sending/receiving data
		OFF	No link detected
LK100	Green	ON	Being linked with 100BASE
		OFF	Being linked with 10BASE or Not linked

DIP SW SETTING

IP Address

SW1-1	Mode	Function
OFF (*)	Normal mode	Set with configurator
ON	Factory default mode	When starting up with the SW ON, the unit temporarily operates by the factory default settings of network configuration, user ID and password. The stored settings, however, are maintained and the unit returns to the original settings upon restarting at normal mode. When network settings are changed during factory default mode, the changed settings are stored.

Maintenance mode

SW1-2	Mode	Function
OFF (*)	Normal mode	Normal operation
ON	Maintenance mode	Stop output (Modbus function 05, 06, 15, 16 are disabled)

■ TERMINATING RESISTOR SW

• Terminating resistor

TERM	INCORPORATED TERMINATING RESISTOR
OFF	Disabled
ON (*)	Enabled

(*)Factory default setting

■ RS-485 CONNECTOR TERMINAL ASSIGNMENT

Unit side connector: MC1,5/5-GF-3,5

(Phoenix Contact)

Cable side connector: TFMC1,5/5-STF-3,5

(Phoenix Contact)

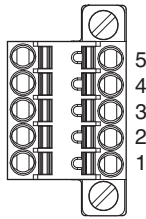

No.	ID	FUNCTION
5	FE	FE
4	SH	SHIELD
3	DG	DG
2	DB	DB (-)
1	DA	DA (+)

■ POWER SUPPLY TERMINAL ASSIGNMENT

Unit side connector: MSTB2,5/3-G

(Phoenix Contact)

Cable side connector: MSTB2,5/3-ST

(Phoenix Contact)

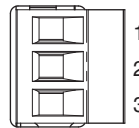

No.	ID	FUNCTION
1	U(+)	Power supply
2	V(-)	Power supply
3	FE1	Power supply earth

COMMUNICATION CABLE CONNECTIONS

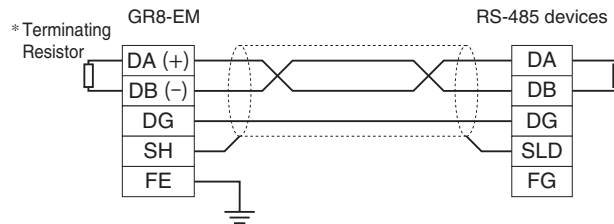

* Turn the terminating resistor SW "ON" to use the incorporated terminating resistor.

EXTERNAL DIMENSIONS unit: mm [inch]

■ COUPLED WITH DL8

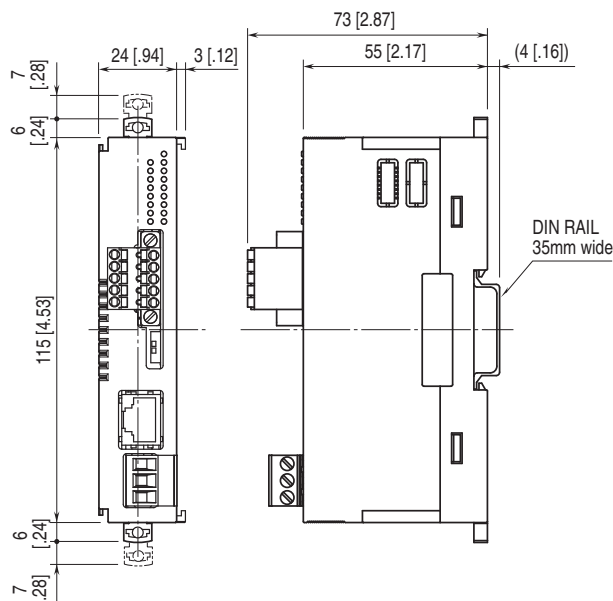

■ SINGLE USE

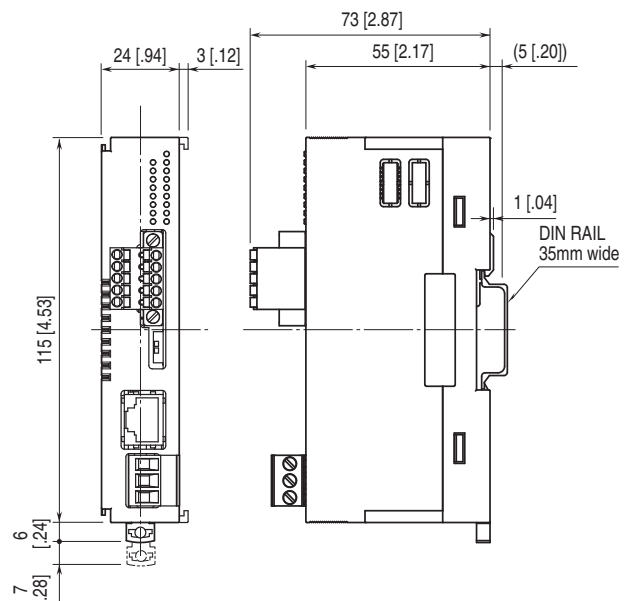

SCHEMATIC CIRCUITRY & CONNECTION DIAGRAM

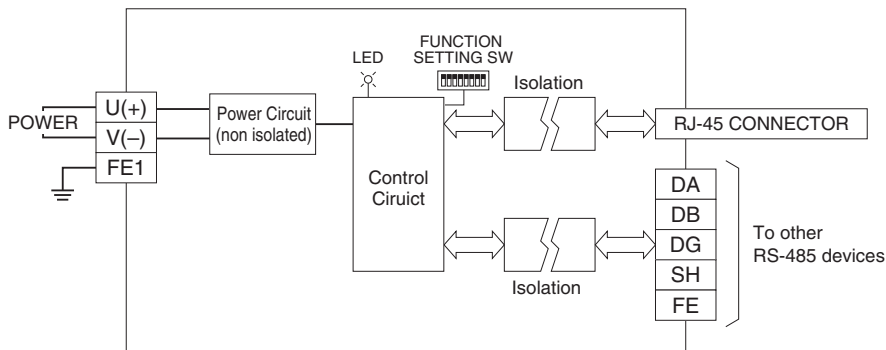

SYSTEM CONFIGURATION EXAMPLES

Devices other than the GR8-EM in below provided by the user.

■ COUPLED WITH DL8

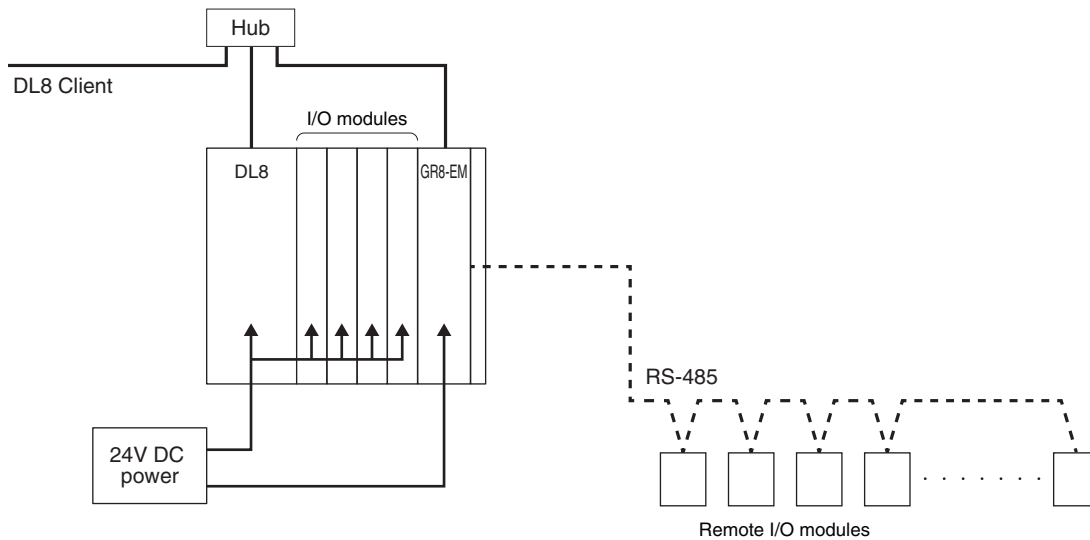

Note: It is not available to supply the power via DL8.
Supply the power with the connector for power supply.

■ SINGLE USE

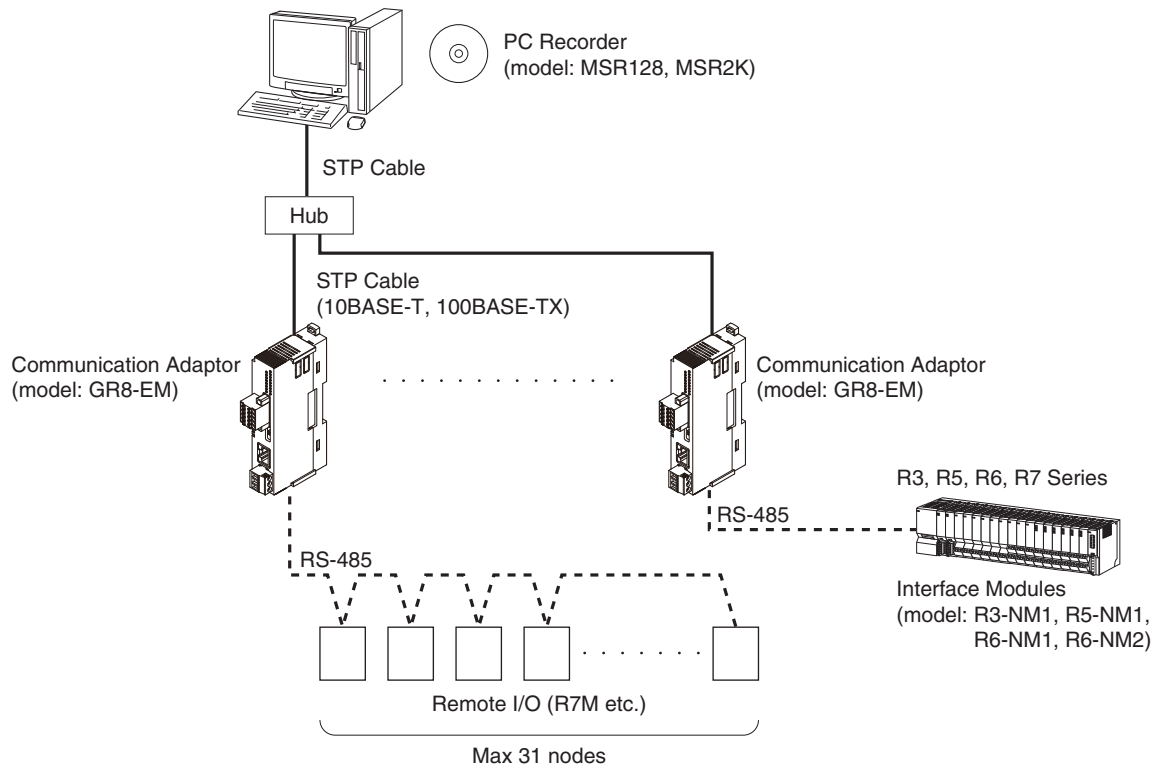

Specifications are subject to change without notice.