

**Tower Light Series**

**WIRELESS LAN TOWER LIGHT**

(small size, 50 mm dia., Modbus/TCP, 1 - 5 layers, bridge)

**Functions & Features**

- Lighting, blinking and buzzing available with contact input or PC via Modbus/TCP.
- Contact input status acquisition available through wireless LAN.
- Connection to network with bridge function, in remote I/O Ethernet type via wireless LAN.
- Wireless LAN connection complied with IEEE802.11b/g/n
- Nondirectional antenna (360°horizontal)

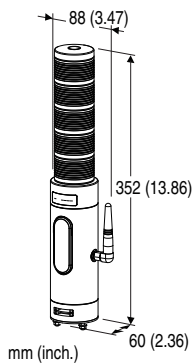

Lamp Layers	A
1	224 (8.82)
2	256 (10.08)
3	288 (11.34)
4	320 (12.60)
5	352 (13.86)

**MODEL: IT50SW1-[1][2][3][4][5][6]D2-R[7]**

**ORDERING INFORMATION**

- Code number: IT50SW1-[1][2][3][4][5][6]D2-R[7]  
Specify a code from below for each of [1] through [7].  
(e.g. IT50SW1-5RYGBWD2-R/Q)
- Specify the specification for option code /Q  
(e.g. /C01)

**[1] LAMP LAYERS**

- 1: 1 layer
- 2: 2 layers
- 3: 3 layers
- 4: 4 layers
- 5: 5 layers

**[2] LAMP 1 COLOR**

(1st layer from the top)

- R: Red
- Y: Amber
- G: Green
- B: Blue
- W: White

**[3] LAMP 2 COLOR**

(2nd layer from the top)

- R: Red
- Y: Amber
- G: Green
- B: Blue
- W: White

N: None (not available when Lamp Layers selected are 2 - 5)

**[4] LAMP 3 COLOR**

(3rd layer from the top)

- R: Red
- Y: Amber
- G: Green
- B: Blue
- W: White

N: None (not available when Lamp Layers selected are 3 - 5)

**[5] LAMP 4 COLOR**

(4th layer from the top)

- R: Red
- Y: Amber
- G: Green
- B: Blue
- W: White

N: None (not available when Lamp Layers selected are 4 - 5)

**[6] LAMP 5 COLOR**

- R: Red
- Y: Amber
- G: Green
- B: Blue
- W: White

N: None (not available when Lamp Layers selected are 5)

\* The selection of the same color for more than one layer is not available.

\* Select "None" option for the layers other than the selected.

**MOUNTING**

- D: Direct mounting

## DESIGN TYPE

2: Type 2  
(refer to outline dimensions)

## POWER INPUT

DC Power  
R: 24 V DC  
(Operational voltage range 24 V  $\pm$ 10 %, ripple 10 %p-p max.)

## COUNTRY

blank: Japan, EU

## [7] OPTIONS

blank: none  
/Q: With options (specify the specification)

## SPECIFICATIONS OF OPTION: Q

COATING (For the detail, refer to our web site.)  
/C01: Silicone coating  
/C02: Polyurethane coating  
/C03: Rubber coating

## RELATED PRODUCTS

- LAN cable (model: ITCA)
  - Mounting Pole (model: ITPL, ITB, ITP, ITW and ITS)
  - Mounting Adapter (model: ITAD1, ITAM, ITAR and ITAW)
  - PC configurator software (model: ITCFG)
- Functions are configurable using the PC Configurator Software.  
Downloadable at our web site.

## GENERAL SPECIFICATIONS

**Degree of protection:** IP 65, vertical mounting only (bottom connectors excluded)

### Connection

**Power:** UL1007 AWG20  
**Input:** UL1007 AWG22  
**Ethernet:** RJ-45 Modular Jack

**Housing material:** Flame-resistant resin

**Lens:** Flame-resistant resin (transparent)

**Isolation:** Discrete input or power input to network

**DIP SW Setting:** Frequency of lamp blinking and buzzing discontinuance, buzzing volume level, output at connection failed and IP address (refer to the instruction manual)

**Lamp:** Red, amber, green, blue and white LEDs on/blinking (approx. 2 Hz, 10 Hz)

**Status indicator LEDs:** Power, Run  
(Refer to the instruction manual)

**Buzzing:** Approx. 3.3 kHz

**Interval:** continuous/intermittent (approx. 2 Hz, 10 Hz)

## COMMUNICATION

### ■ Common spec.

Modbus protocol  
**Protocol:** Modbus/TCP  
**Data:** RTU (Binary)  
**Port No.:** 502

**Max. number of socket connections:** 10

**IP address:** 192.168.0.1 (factory setting);  
Selectable with PC Configurator Software  
(model: ITCFG)

### ■ Ethernet

**Communication Standard:** IEEE 802.3u  
**Transmission:** 10BASE-T, 100BASE-TX  
**Baud rate:** 10/100 Mbps (Auto Negotiation function)  
**Transmission media:** 10BASE-T (STP, Category 5) 100BASE-TX (STP, Category 5e)

**Max. length of fieldbus segment:** 100 meters

**IP address:** 192.168.0.1 (factory setting);  
Selectable with PC Configurator Software

**Ethernet indicator LED:** Link, Link100, COL

### ■ Wireless LAN

**Communication Standard:** IEEE 802.11b/g/n  
**Frequency range:** 2400 - 2483.5 MHz (ch1 - ch13)  
**Max. transmission distance (optical):** Approx. 50 m (depends on setting)

**Access mode:** infrastructure/ad hoc

**Security:** WEP 64bit/128bit, WPA (TKIP, AES), WPA2 (TKIP, AES)

**Wireless LAN indicator:** WLAN1

## INPUT SPECIFICATIONS

■ **Discrete Input:** Dry contact, open collector NPN

**Input resistance:** Approx. 4.4 k $\Omega$

**Common:** Negative common NPN

**ON level:**  $\leq 5$  V /  $\geq 3.5$  mA (Input - COM)

**OFF level:**  $\geq 18$  V DC /  $\leq 1$  mA (Input - COM)

**Input current:**  $\leq 5.5$  mA per point @ 24 V DC

## INSTALLATION

### Power consumption

•DC: Approx. 5.5 W

**Operating temperature:** -10 to +55°C (14 to 131°F)

**Operating humidity:** 30 to 85 %RH (non-condensing)

**Atmosphere:** No corrosive gas

**Mounting:** Direct mounting

**Mounting direction:** Vertical

**Weight:** 700 g (1.5 lb)

## PERFORMANCE

**Insulation resistance:**  $\geq 100 \text{ M}\Omega$  with 500 V DC

**Dielectric strength:** 1500 V AC @ 1 minute (discrete input or power to network)

## STANDARDS & APPROVALS

- Built-in module certified under Japanese Radio Law
- **EU conformity:**
  - RE Directive
    - EN 300 328 V2.2.2
  - RoHS Directive
- EN 301 489-1 V1.9.2
- EN 60950-1

## EXTERNAL VIEW

### FRONT VIEW (with the cover open)

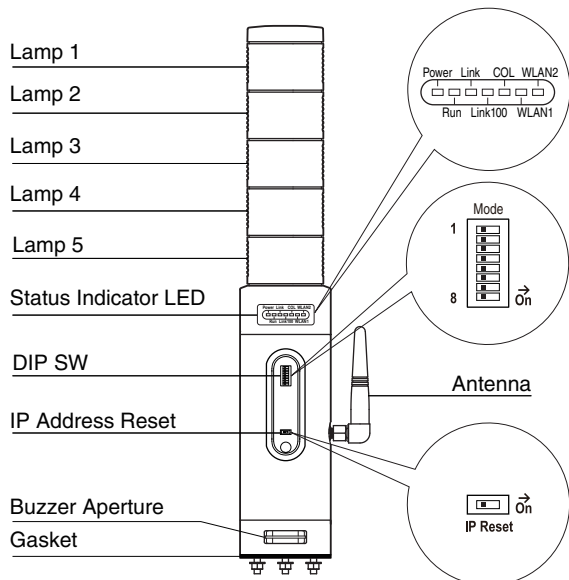

### BOTTOM VIEW

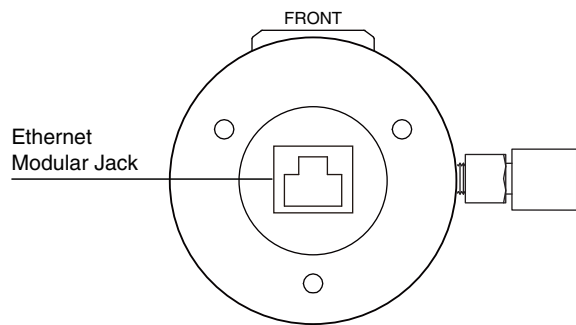

## EXTERNAL DIMENSIONS unit: mm

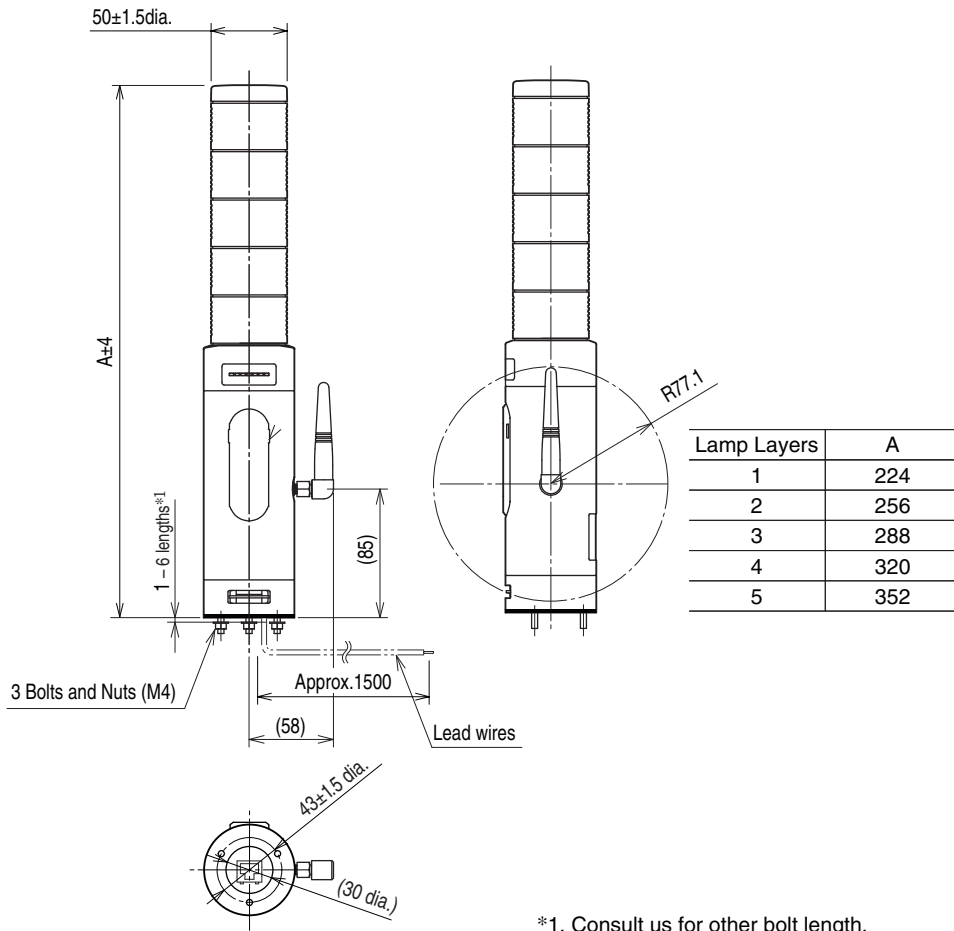

## MOUNTING REQUIREMENTS unit: mm

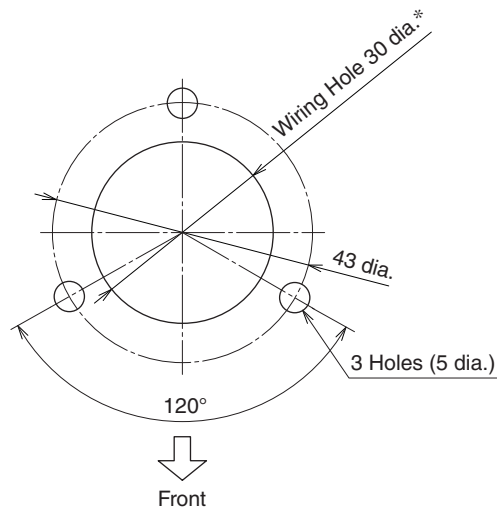

\* Protect wires to prevent scratching them at the edge of the compartment.

## SCHEMATIC CIRCUITRY & CONNECTION DIAGRAM

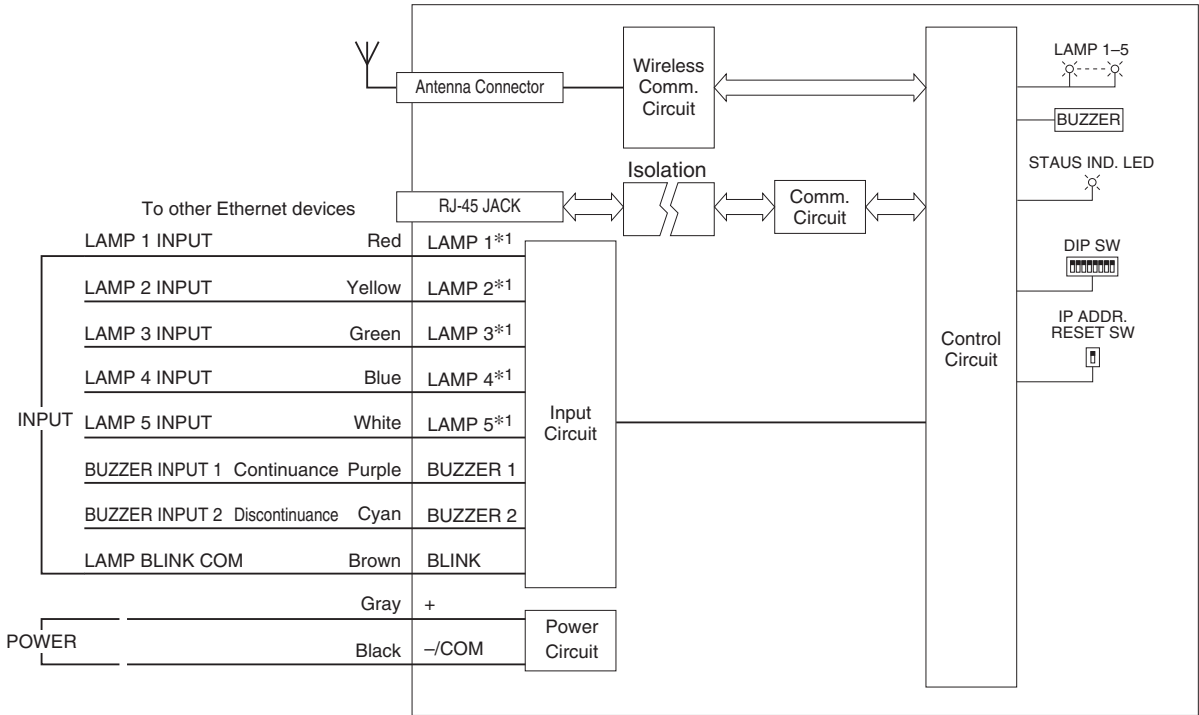

\*1. Example of 5 layers in order: red, yellow, green, blue and white.  
Lamp and wire color are the same.

### ■ WIRING TO INPUT SIGNAL

• Contact input e.g.

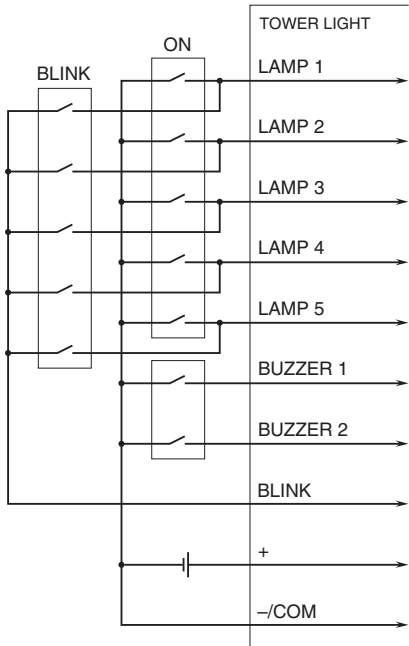

•NPN input e.g.

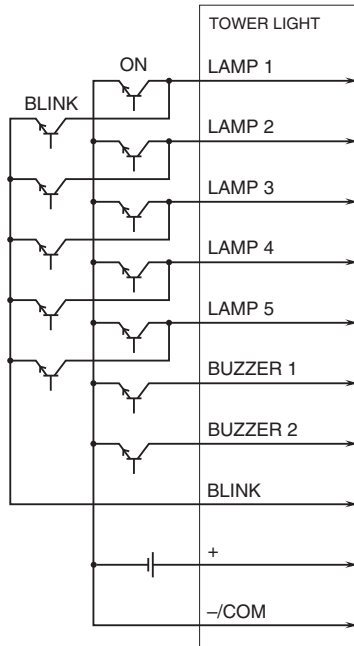

Note 1: If "On" (Continuous) and "Blink" (Intermittent) are set simultaneously for a single lamp (buzzer), "Blink" (Intermittent) is disabled.  
The same procedure will be applied also for the others lamps.

## SYSTEM CONFIGURATION EXAMPLES

### ■ EXAMPLE 1: LEDs ON with discrete input. The status is obtained with the PC via wired and wireless communication.

1. Activate the tower light lamp and buzzer with contact input .
2. Acquire data of contact status of tower light lamp with PC.

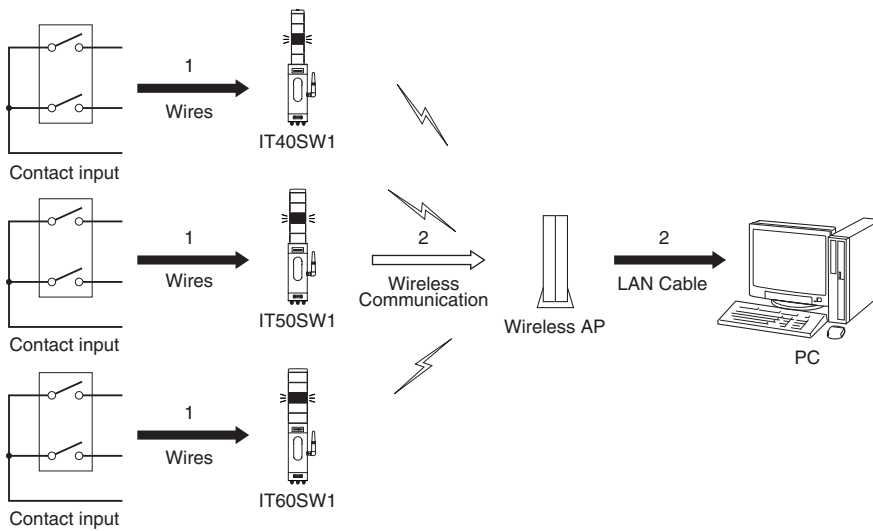

### ■ EXAMPLE 2: LEDs ON with the PC via wired and wireless communication.

1. Activate the tower light lamp and buzzer with PC.

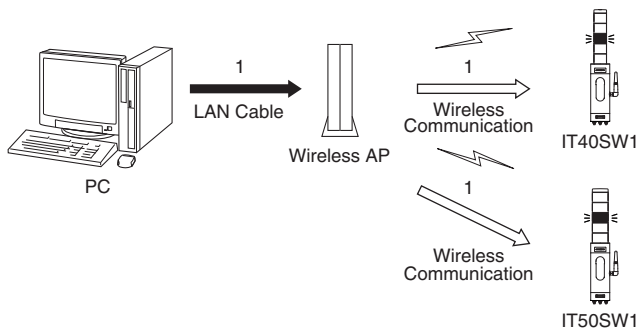

### ■ EXAMPLE 3: The PC is connected to the remote I/O via wired and wireless (bridge) communication.

1. Activate the tower light lamp and buzzer with PC.
2. Interchange data between PC and Remote I/O.

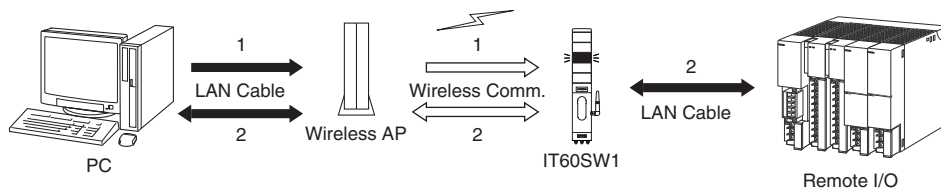

Contact status of tower light described on example 1 is also available while interchanging data with PC.



Specifications are subject to change without notice.