

Remote I/O JC Series

HUB MODULE

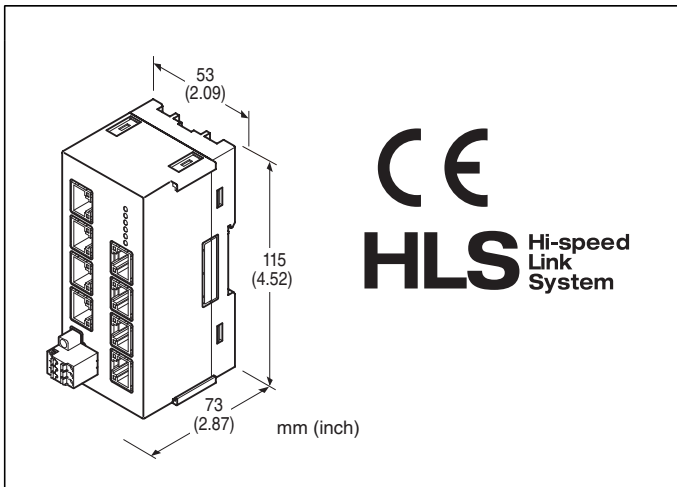

MODEL: JC-HL-[1]-1[2]-[3][4]

ORDERING INFORMATION

- Code number: JC-HL-[1]-1[2]-[3][4]
- Specify a code from below for each of [1] through [4].
(e.g. JC-HL-7-12-R/H/Q)
- Specify the specification for option code /Q
(e.g. /SET)

[1] I/O TYPE

- 3: 3 port (trunk 1 port, feeder 2 port)
- 7: 7 port (trunk 1 port, feeder 6 port)

TERMINAL BLOCK

- 1: Tension clamp terminal block for power supply
- RJ-45 Modular jack for communication

[2] COMMUNICATION CONNECTOR PIN ASSIGNMENT

- 1: 3, 4 - 5, 6 pair wiring
(The HLS related products standard pin assignment)
- 2: 4, 5 - 3, 6 pair wiring
(Ethernet LAN cable pin assignment)

[3] POWER INPUT

- DC Power
- R: 24 V DC
(Operational voltage range 24 V \pm 10 %, ripple 10 %p-p max.)
- R5: 16 - 32 V DC
(Operational voltage range 15 - 33 V DC, ripple 10 %p-p max.)

[4] OPTIONS (multiple selections)

- Communication Mode
- blank: Full-duplex
- /H: Half-duplex
- Other Options
- blank: none
- /Q: Option other than the above (specify the specification)

SPECIFICATIONS OF OPTION: Q

- EX-FACTORY SETTING
- /SET: Preset according to the Ordering Information Sheet
(No. ESU-9041)

FUNCTIONS & FEATURES

The HUB Module for HLS (model: JC-HL) extends total length of network cable and branch cable of HLS (Hi-speed Link System). Total max. length is 2.4 km when transfer rate is 3 Mbps. In order to connect the JC-HL, the master unit configuring HLS must support HUB module.

HLS is the abbreviation for "Hi-speed Link System" of Step Technica Co., Ltd.

RELATED PRODUCTS

- High-speed link system I/O modules (model: R7F4DH, R7K4DH, R7HL, R7FN etc.)
- MP2200/MP2300 series use HLS master module (model: MPHLS)

GENERAL SPECIFICATIONS

- Number of port:**
JC-HL-3: Trunk 1 port, feeder 2 port
JC-HL-7: Trunk 1 port, feeder 6 port
Max. number of inserted HUBs: 7
(Depending on specification of master unit)
- Connectable devices:** The products conforming to HLS Connection
- Network:** RJ-45 Modular Jack
- Power input:** Separable tension clamp terminal
- Power on LED:** PWR (green) turns on while the power is supplied.

HLS COMMUNICATION

- Communication mode:** Full-duplex or half-duplex
- Network cable**
 - Shield cable
ZHY262PS (Shinko Seisen Industry Co., Ltd.)
ZHT262PS (Shinko Seisen Industry Co., Ltd.)
 - Dual-shield cable
ZHY262PBA (Shinko Seisen Industry Co., Ltd.)

Transmission distance / Transfer rate:

Refer to the table below (Selectable with DIP switch. Factory default: 12 Mbps)

Terminating resistor:

Trunk built-in (Selectable with DIP switch. Factory default: disable)

Feeder built-in

Status indicator LEDs: ERR, LNK

(Refer to the instruction manual for details)

Transfer rate	Number of inserted HUBs							
	0	1	2	3	4	5	6	7
12Mbps	100m	200m	300m	400m	500m	600m	700m	800m
6Mbps	200m	400m	800m	1km	1.2km	1.4km	1.6km	1.8km
3Mbps	300m	600m	900m	1.2km	1.5km	1.8km	2.1km	2.4km

MOUNTING REQUIREMENTS unit: mm (inch)

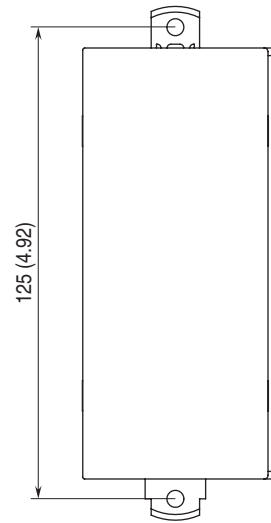

INSTALLATION

Rated current for power supply connector: 8A

Power consumption:

JC-HL-3: Approx. 1 W

JC-HL-7: Approx. 1.4 W

Operating temperature: -10 to +55°C

Operating humidity: 10 to 90 %RH (non-condensing)

Atmosphere: No corrosive gas or heavy dust

Mounting: Surface or DIN rail

Weight

JC-HL-3: 150 g (0.33 lb)

JC-HL-7: 160 g (0.35 lb)

PERFORMANCE

Insulation resistance: $\geq 100 \text{ M}\Omega$ with 500 V DC

JC-HL-3 (HLS0A or HLS0B to HLS1 or HLS2 or FE to power)

JC-HL-7 (HLS0A or HLS0B to HLS1 or HLS2 or HLS3 or HLS4 or HLS5 or HLS6 or FE to power)

Dielectric strength: 1500 V AC @ 1 minute

JC-HL-3 (HLS0A or HLS0B to HLS1 or HLS2 or FE to power)

JC-HL-7 (HLS0A or HLS0B to HLS1 or HLS2 or HLS3 or HLS4 or HLS5 or HLS6 or FE to power)

STANDARDS & APPROVALS

Refer to the manuals to comply with the standards.

EU conformity:

EMC Directive

EMI EN 61000-6-4

EMS EN 61000-6-2

RoHS Directive

EXTERNAL VIEW

- I/O TYPE : 3 3port
- SIDE VIEW

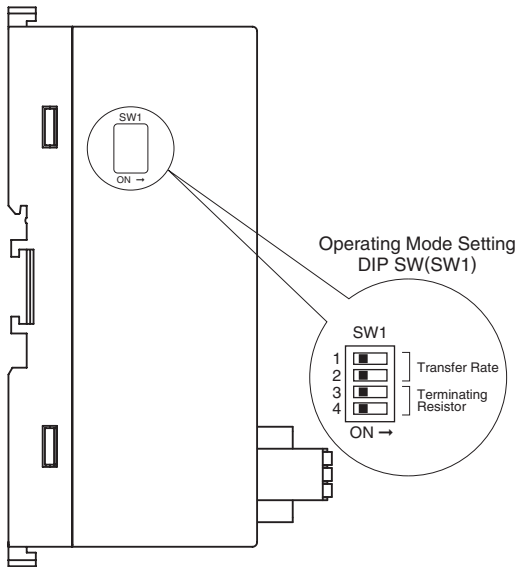

- FRONT VIEW

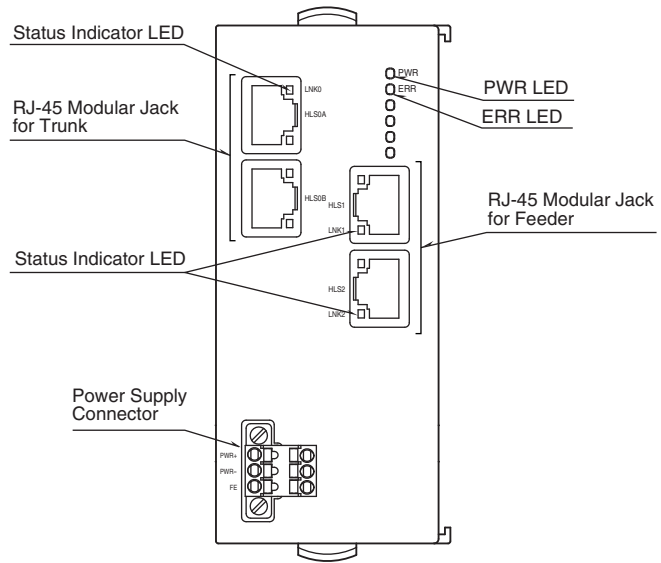

- I/O TYPE : 7 7port
- SIDE VIEW

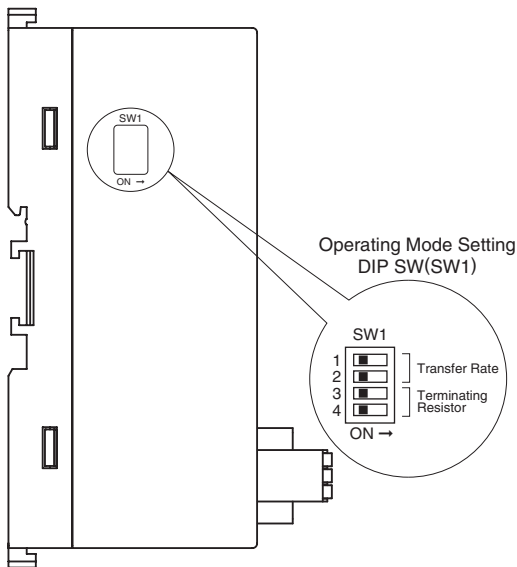

- FRONT VIEW

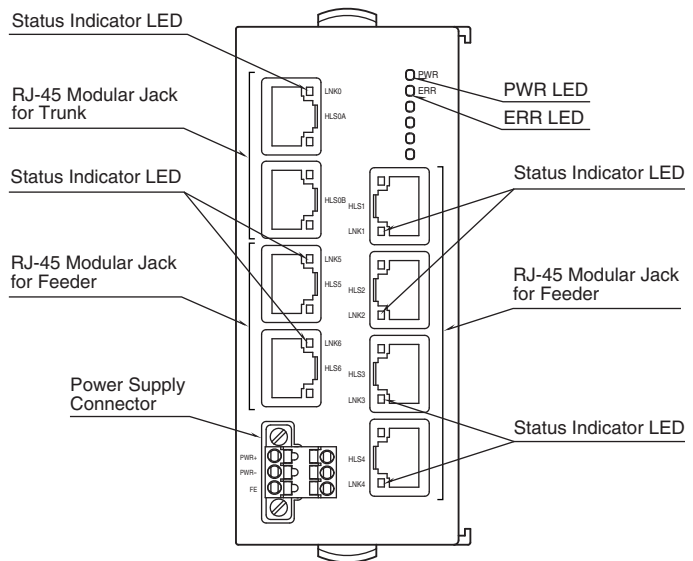

CONNECTION DIAGRAMS

■ POWER SUPPLY

Cable connector: TFMC1,5 / 5-STF-3,5
(Phoenix Contact) (included in the package)

Applicable wire size: 0.2 – 1.5 mm²; stripped length 10 mm

Recommended solderless terminal

- AI0,25-10YE 0.25 mm² (Phoenix Contact)
- AI0,34-10TQ 0.34 mm² (Phoenix Contact)
- AI0,5-10WH 0.5 mm² (Phoenix Contact)
- AI0,75-10GY 0.75 mm² (Phoenix Contact)
- A1-10 1.0 mm² (Phoenix Contact)
- A1,5-10 1.5 mm² (Phoenix Contact)

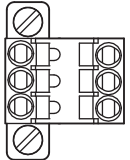

- | | | |
|---|----------|------------------|
| 1 | 1. PWR + | Power Supply |
| 2 | 2. PWR - | Power Supply |
| 3 | 3. FE | Functional earth |

■ NETWORK

Recommended cable connector: TM21P-88P (Hirose Electric)
(not included in the package)

• COMMUNICATION CONNECTOR PIN ASSIGNMENT CODE: 1

Full-duplex communication

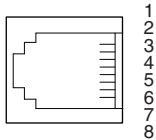

Trunk (HLS0A, HLS0B)

- | | |
|---------|----------------------------------|
| 1. NC | Unused |
| 2. NC | Unused |
| 3. TXD+ | Network (HUB, transmission +) |
| 4. TXD- | Network (HUB, transmission -) |
| 5. RXD+ | Network (master, transmission +) |
| 6. RXD- | Network (master, transmission -) |
| 7. NC | Unused |
| 8. SLD | Shield |

Feeder (HLS1, HLS2, HLS3, HLS4, HLS5, HLS6)

- | | |
|---------|---------------------------------|
| 1. NC | Unused |
| 2. NC | Unused |
| 3. RXD+ | Network (slave, transmission +) |
| 4. RXD- | Network (slave, transmission -) |
| 5. TXD+ | Network (HUB, transmission +) |
| 6. TXD- | Network (HUB, transmission -) |
| 7. NC | Unused |
| 8. SLD | Shield |

Half-duplex communication

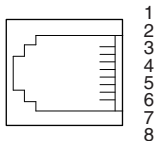

Trunk (HLS0A, HLS0B)

- | | |
|--------|-------------|
| 1. NC | Unused |
| 2. NC | Unused |
| 3. TR+ | Network (+) |
| 4. TR- | Network (-) |
| 5. NC | Unused |
| 6. NC | Unused |
| 7. NC | Unused |
| 8. SLD | Shield |

Feeder (HLS1, HLS2, HLS3, HLS4, HLS5, HLS6)

- | | |
|--------|-------------|
| 1. NC | Unused |
| 2. NC | Unused |
| 3. TR+ | Network (+) |
| 4. TR- | Network (-) |
| 5. NC | Unused |
| 6. NC | Unused |
| 7. NC | Unused |
| 8. SLD | Shield |

• **COMMUNICATION CONNECTOR PIN ASSIGNMENT CODE: 2**

Full-duplex communication

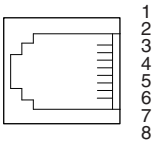

Trunk (HLS0A, HLS0B)

- 1. NC Unused
- 2. NC Unused
- 3. TXD+ Network (HUB, transmission +)
- 4. RXD- Network (master, transmission -)
- 5. RXD+ Network (master, transmission +)
- 6. TXD- Network (HUB, transmission -)
- 7. NC Unused
- 8. SLD Shield

Feeder (HLS1, HLS2, HLS3, HLS4, HLS5, HLS6)

- 1. NC Unused
- 2. NC Unused
- 3. RXD+ Network (slave, transmission +)
- 4. TXD- Network (HUB, transmission -)
- 5. TXD+ Network (HUB, transmission +)
- 6. RXD- Network (slave, transmission -)
- 7. NC Unused
- 8. SLD Shield

Half-duplex communication

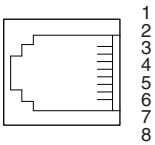

Trunk (HLS0A, HLS0B)

- 1. NC Unused
- 2. NC Unused
- 3. NC Unused
- 4. TR- Network (-)
- 5. TR+ Network (+)
- 6. NC Unused
- 7. NC Unused
- 8. SLD Shield

Feeder (HLS1, HLS2, HLS3, HLS4, HLS5, HLS6)

- 1. NC Unused
- 2. NC Unused
- 3. NC Unused
- 4. TR- Network (-)
- 5. TR+ Network (+)
- 6. NC Unused
- 7. NC Unused
- 8. SLD Shield

■ MASTER, SLAVE CONNECTION

• Full-duplex communication

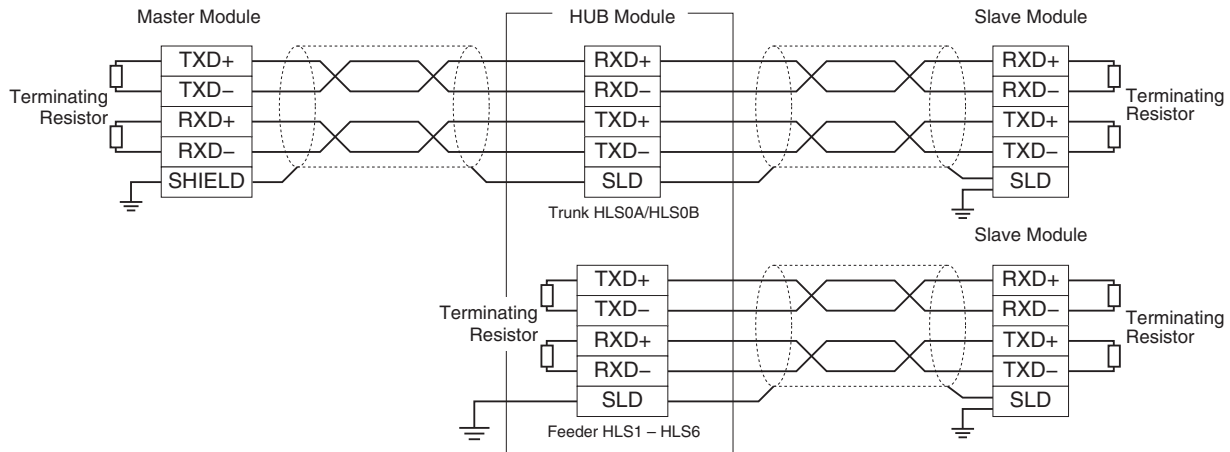

• Half-duplex communication

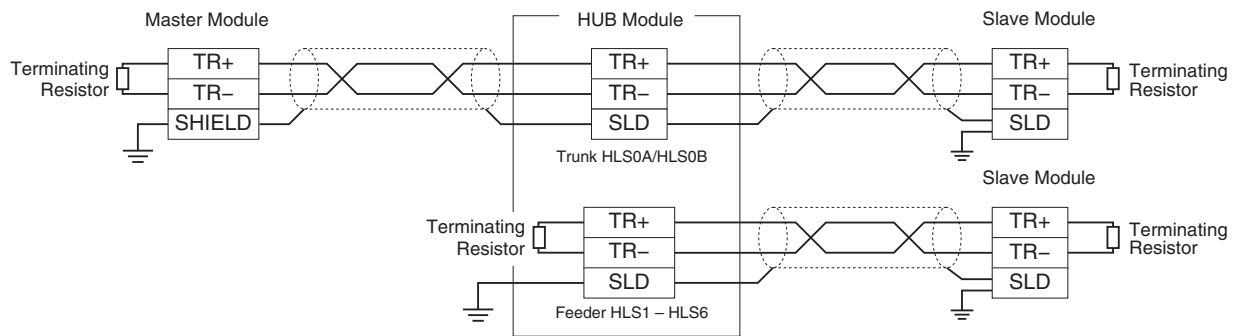

Note: Be sure to turn ON the switch of the terminating resistor located at both ends of the modules.

DIMENSIONS unit: mm (inch)

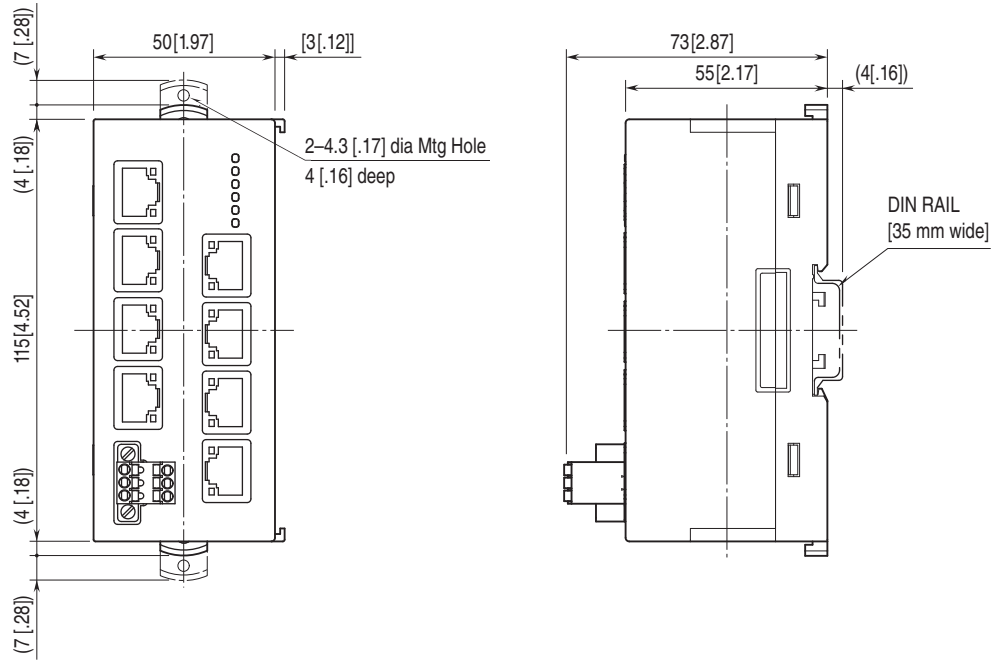

SCHEMATIC CIRCUITRY

Note: In order to improve EMC performance, bond the FE terminal to ground.

Caution: FE terminal is NOT a protective conductor terminal.

■ JC-HL-3-11

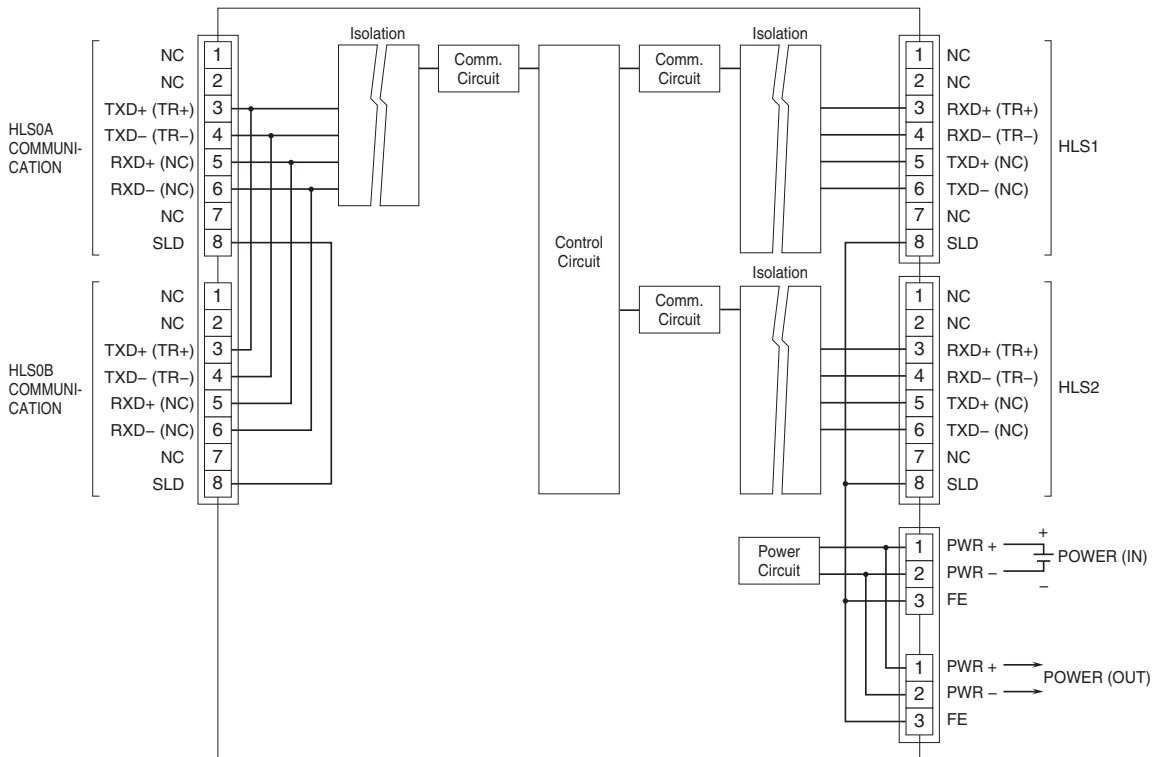

■ JC-HL-7-11

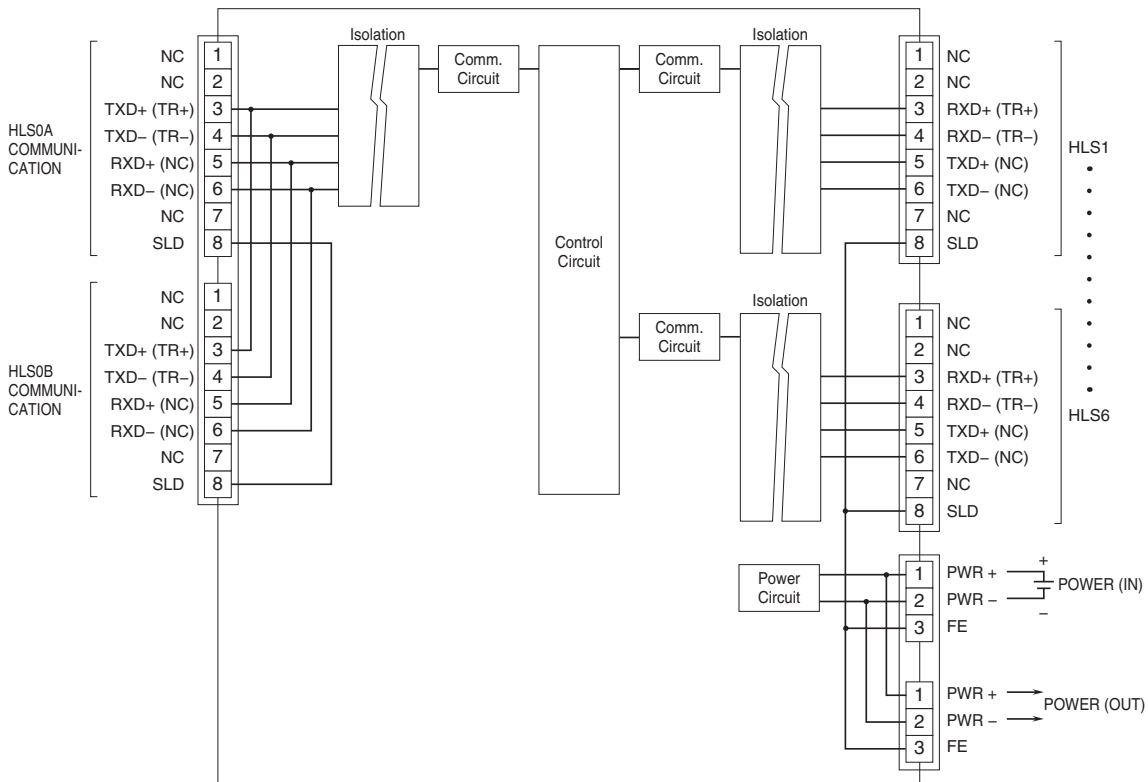

■ JC-HL-3-12

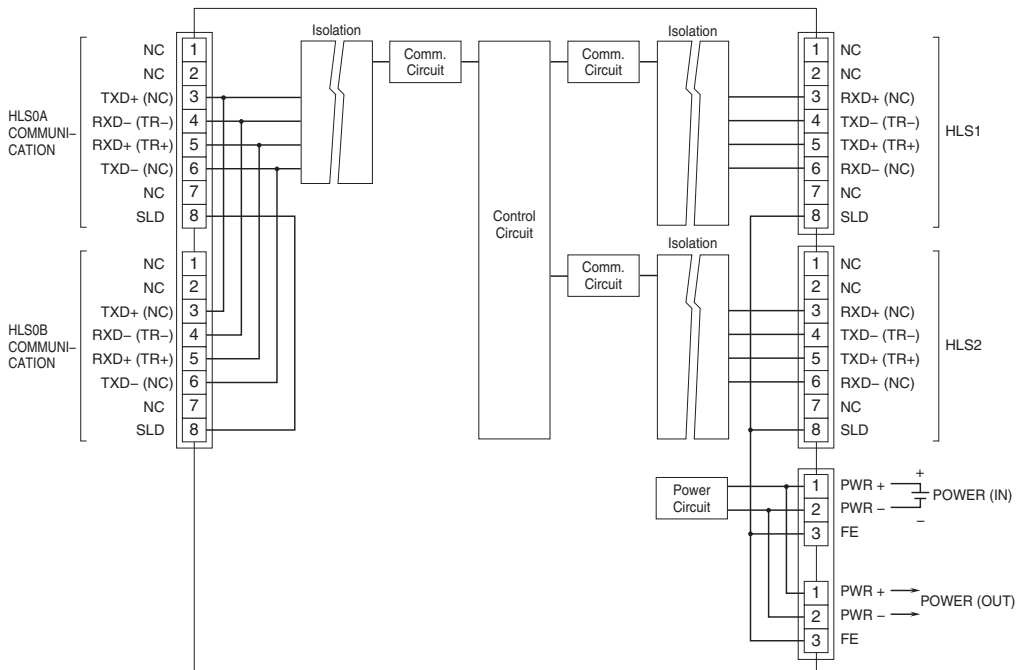

■ JC-HL-7-12

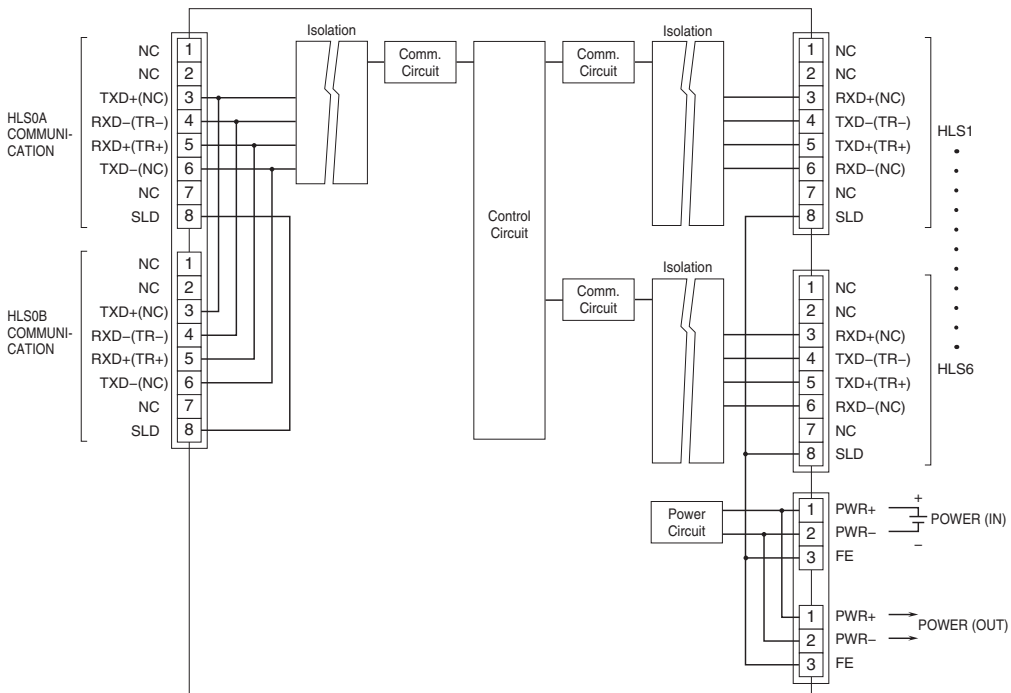

SYSTEM CONFIGURATION EXAMPLES

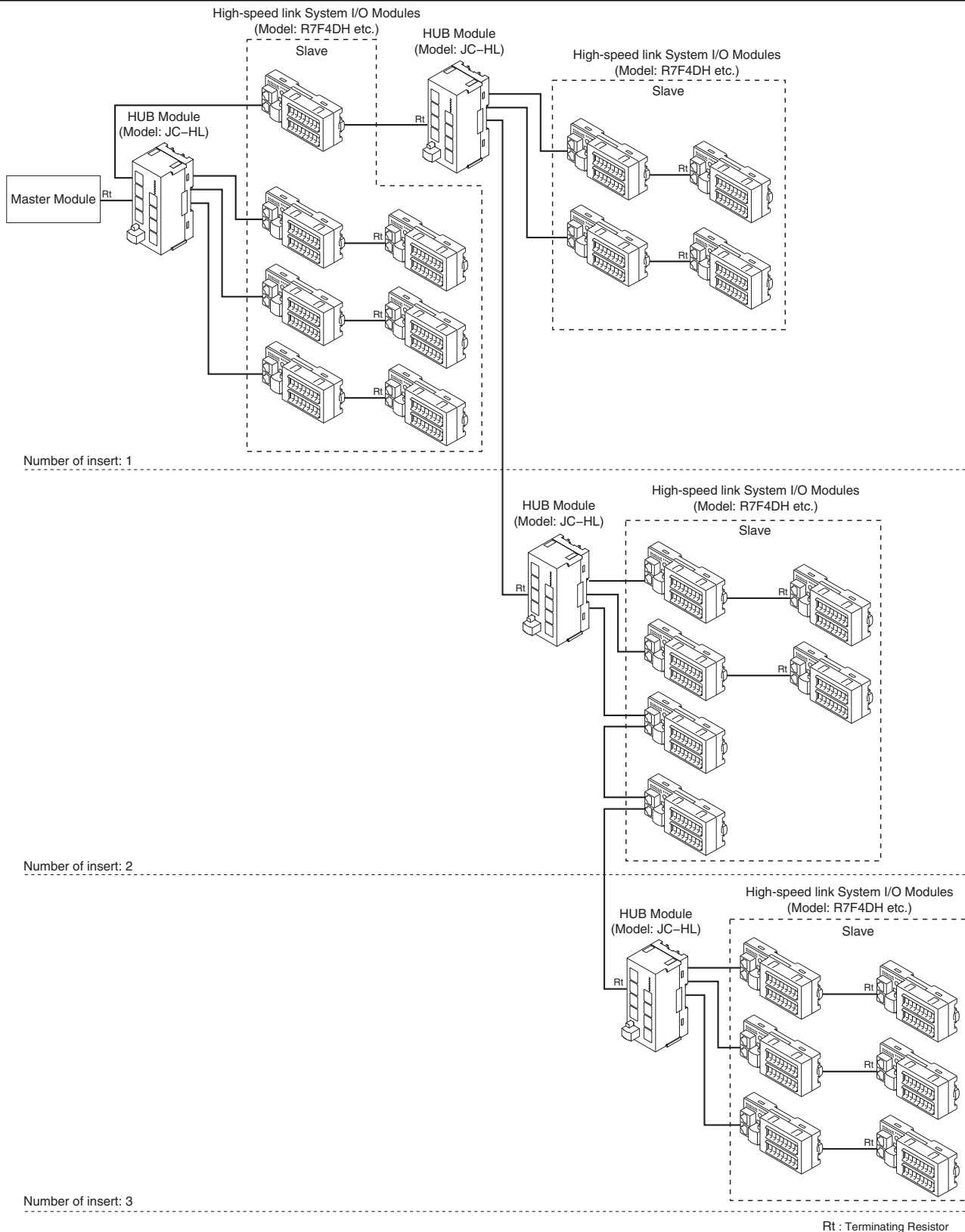

Note 1) Max. transmission distance between master module and HUB module, HUB module and HUB module, HUB module and slave module is as follows. 100 m at 12 Mbps, 200 m at 6 Mbps and 300 m at 3 Mbps.

Note 2) Be sure to connect HLS0A/HLS0B to the host side.

Note 3) The terminating resistor must be enabled for the modules at both end of the communication line. The terminating resistor is incorporated in the feeder side port of the HUB module.



Specifications are subject to change without notice.