

Plug-in Signal Conditioners M-UNIT

LINEARIZER

(field-programmable)

Functions & Features

- Accepting non-linear input and providing linearized output, proportional to the process variables
- Micro-processor based
- On-site calibration up to 16 points using a hand-held programmer PU-2x
- Field-programmable input range
- Isolation up to 2000 V AC
- High-density mounting

Typical Applications

- V-notch weir
- Gas analyzer
- Irregular-shaped tank level input for volume calculation
- Square root extracting for DP transmitter

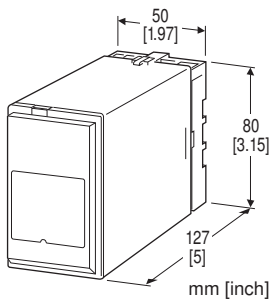

MODEL: JFX-[1][2]-[3][4]

ORDERING INFORMATION

- Code number: JFX-[1][2]-[3][4]
- Specify a code from below for each of [1] through [4].
(e.g. JFX-6A-B/Q)
- Special input and output ranges (For codes U1, U2, U3, Z & 0)
 - Linearization data (max. 16 points)
- Use Ordering Information Sheet (No. ESU-1669) to specify linearization data when the I/O signals are nonlinear.
- Specify the specification for option code /Q
(e.g. /C01/S01)

[1] INPUT

Current

- A:** 4 - 20 mA DC (Input resistance 250 Ω)
 - H:** 10 - 50 mA DC (Input resistance 100 Ω)
- Voltage
- 6:** 1 - 5 V DC (Input resistance 1 MΩ min.)

- U1:** Range ±100 mV;
(Minimum span 3 mV, Input resistance 20 kΩ min.)
- U2:** Range ±1000 mV;
(Minimum span 30 mV, Input resistance 20 kΩ min.)
- U3:** Range ±10 V;
(Minimum span 0.3 V, Input resistance 1 MΩ min.)

[2] OUTPUT

Current

- A:** 4 - 20 mA DC (Load resistance 750 Ω max.)
- B:** 2 - 10 mA DC (Load resistance 1500 Ω max.)
- C:** 1 - 5 mA DC (Load resistance 3000 Ω max.)
- D:** 0 - 20 mA DC (Load resistance 750 Ω max.)
- E:** 0 - 16 mA DC (Load resistance 900 Ω max.)
- F:** 0 - 10 mA DC (Load resistance 1500 Ω max.)
- G:** 0 - 1 mA DC (Load resistance 15 kΩ max.)
- Z:** Specify current (See OUTPUT SPECIFICATIONS)

Voltage

- 1:** 0 - 10 mV DC (Load resistance 10 kΩ min.)
- 2:** 0 - 100 mV DC (Load resistance 100 kΩ min.)
- 3:** 0 - 1 V DC (Load resistance 1000 Ω min.)
- 4:** 0 - 10 V DC (Load resistance 10 kΩ min.)
- 5:** 0 - 5 V DC (Load resistance 5000 Ω min.)
- 6:** 1 - 5 V DC (Load resistance 5000 Ω min.)
- 4W:** -10 - +10 V DC (Load resistance 10 kΩ min.)
- 5W:** -5 - +5 V DC (Load resistance 5000 Ω min.)
- 0:** Specify voltage (See OUTPUT SPECIFICATIONS)

[3] POWER INPUT

AC Power

- B:** 100 V AC
- C:** 110 V AC
- D:** 115 V AC
- F:** 120 V AC
- G:** 200 V AC
- H:** 220 V AC
- J:** 240 V AC

DC Power

- S:** 12 V DC
- R:** 24 V DC
- V:** 48 V DC

[4] OPTIONS

- blank:** none
- /Q:** With options (specify the specification)

SPECIFICATIONS OF OPTION: Q (multiple selections)

- COATING (For the detail, refer to our web site.)
- /C01:** Silicone coating
- /C02:** Polyurethane coating

/C03: Rubber coating
 TERMINAL SCREW MATERIAL
 /S01: Stainless steel

RELATED PRODUCTS

- Programming Unit (model: PU-2x)
- PC configurator software (model: JXCON)

Downloadable at our web site.

A dedicated cable is required to connect the module to the PC. Please refer to the internet software download site or the users manual for the PC configurator for applicable cable types.

GENERAL SPECIFICATIONS

Construction: Plug-in

Connection: M3.5 screw terminals

Screw terminal: Chromated steel (standard) or stainless steel

Housing material: Flame-resistant resin (black)

Isolation: Input to output to power

Zero adjustment: -5 to +5 % (front)

Span adjustment: 95 to 105 % (front)

Linearization: 16 points max. within the range of -15.00 – +115.00 % input or output; represented as percentage of full-scale

Adjustments: Programming Unit (model: PU-2x)
 (Refer to the users manual of JXCON for the adjustments configurable with JXCON.)

- Linearization data
- Input range
- Zero and span
- Simulating output
- Others

Input range can be changed with Codes U1, U2 or U3 and limited within ranges of each code type.

INPUT SPECIFICATIONS

■ **DC Current:**

Shunt resistor attached to the input terminals (0.5 W)

■ **DC Voltage:** -10 – +10 V DC

Minimum span: 3 mV

Offset: Max. 3 times span

Input resistance (Input Range: Input Resistance)

U1: ±100 mV

U2: ±1000 mV

U3: ±10 V

Default setting will be used if not otherwise specified.

U1: 0 – 100 mV DC

U2: 0 – 1 V DC

U3: 0 – 10 V DC

OUTPUT SPECIFICATIONS

■ **DC Current:** 0 – 20 mA DC

Minimum span: 1 mA

Offset: Max. 1.5 times span

Load resistance: Output drive 15 V max.

■ **DC Voltage:** -10 – +20 V DC

Span: Min. 5 mV, max. 20 V

Offset: Max. 1.5 times span

Load resistance: Output drive 1 mA max.; at ≥ 0.5 V

INSTALLATION

Power input

• **AC:** Operational voltage range: rating ±10 %, 50/60 ±2 Hz, approx. 3 VA

• **DC:** Operational voltage range: rating ±10 %, ripple 10 %p-p max., approx. 2 W (90 mA at 24 V)

Operating temperature: -5 to +55°C (23 to 131°F)

Operating humidity: 30 to 90 %RH (non-condensing)

Mounting: Surface or DIN rail

Weight: 350 g (0.77 lb)

PERFORMANCE in percentage of span

Accuracy: ±0.1 % with segment gain ≤ 1 [±0.1 % × gain]
 with segment gain > 1

Temp. coefficient: ±0.015 %/°C (±0.008 %/°F)

Response time: ≤ 0.5 sec. (0 – 90 %)

Line voltage effect: ±0.1 % over voltage range

Insulation resistance: ≥ 100 MΩ with 500 V DC

Dielectric strength: 2000 V AC @1 minute (input to output to power to ground)

EXTERNAL DIMENSIONS unit: mm [inch]

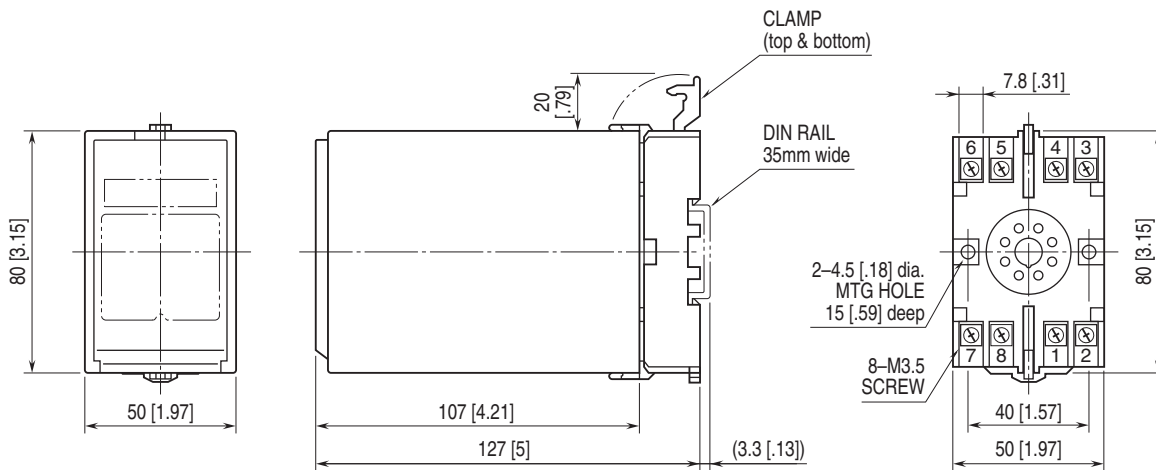

• When mounting, no extra space is needed between units.

TERMINAL ASSIGNMENTS unit: mm [inch]

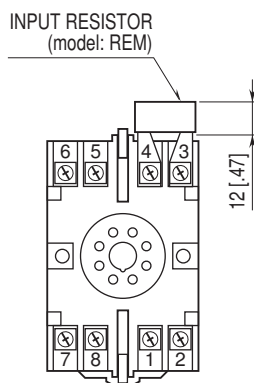

Input shunt resistor attached for current input.

SCHEMATIC CIRCUITRY & CONNECTION DIAGRAM

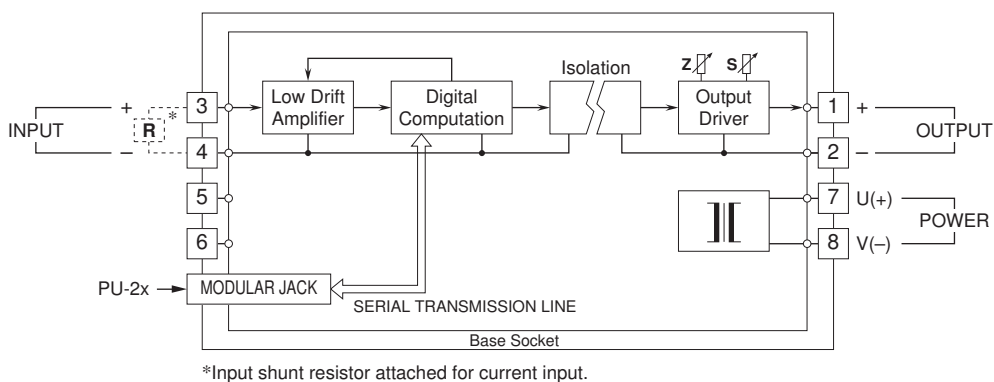



Specifications are subject to change without notice.