

## Plug-in Signal Conditioners M-UNIT

### POTENTIOMETER TRANSMITTER

(field-programmable)

#### Functions & Features

- Providing DC output proportional to a potentiometer or slidewire position input
- Microprocessor based
- Constant voltage excitation allows use with pots with total resistances from 100  $\Omega$  - 10k $\Omega$  without affecting accuracy
- 75 % zero/span adjustments with minimal interaction
- Linearization data programmable via hand-held programmer PU-2x
- Isolation up to 2000 V AC
- Loop testing via hand-held programmer PU-2x
- High-density mounting

#### Typical Applications

- Tank levels
- Positions: Compensating non-linear signal from the linking mechanism of a position detector

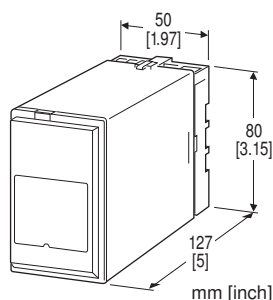

### MODEL: JM-1[1]-[2][3]

#### ORDERING INFORMATION

- Code number: JM-1[1]-[2][3]

Specify a code from below for each of [1] through [3].

(e.g. JM-1A-B/Q)

- Special output ranges (For codes Z & 0)
- Linearization data (max. 16 points)

Use Ordering Information Sheet (No. ESU-1669) to specify linearization data when the I/O signals are non-linear.

- Specify the specification for option code /Q (e.g. /C01/S01)

#### INPUT POTENTIOMETER

1: Total resistance 100  $\Omega$  - 10 k $\Omega$

#### [1] OUTPUT

Current

- A: 4 - 20 mA DC (Load resistance 750  $\Omega$  max.)
- B: 2 - 10 mA DC (Load resistance 1500  $\Omega$  max.)
- C: 1 - 5 mA DC (Load resistance 3000  $\Omega$  max.)
- D: 0 - 20 mA DC (Load resistance 750  $\Omega$  max.)
- E: 0 - 16 mA DC (Load resistance 900  $\Omega$  max.)
- F: 0 - 10 mA DC (Load resistance 1500  $\Omega$  max.)
- G: 0 - 1 mA DC (Load resistance 15 k $\Omega$  max.)
- Z: Specify current (See OUTPUT SPECIFICATIONS)

Voltage

- 1: 0 - 10 mV DC (Load resistance 10 k $\Omega$  min.)
- 2: 0 - 100 mV DC (Load resistance 100 k $\Omega$  min.)
- 3: 0 - 1 V DC (Load resistance 1000  $\Omega$  min.)
- 4: 0 - 10 V DC (Load resistance 10 k $\Omega$  min.)
- 5: 0 - 5 V DC (Load resistance 5000  $\Omega$  min.)
- 6: 1 - 5 V DC (Load resistance 5000  $\Omega$  min.)
- 4W: -10 - +10 V DC (Load resistance 10 k $\Omega$  min.)
- 5W: -5 - +5 V DC (Load resistance 5000  $\Omega$  min.)
- 0: Specify voltage (See OUTPUT SPECIFICATIONS)

#### [2] POWER INPUT

AC Power

- B: 100 V AC
- C: 110 V AC
- D: 115 V AC
- F: 120 V AC
- G: 200 V AC
- H: 220 V AC
- J: 240 V AC

DC Power

- S: 12 V DC
- R: 24 V DC
- V: 48 V DC

#### [3] OPTIONS

blank: none

/Q: With options (specify the specification)

#### SPECIFICATIONS OF OPTION: Q (multiple selections)

COATING (For the detail, refer to our web site.)

/C01: Silicone coating

/C02: Polyurethane coating

/C03: Rubber coating

TERMINAL SCREW MATERIAL

/S01: Stainless steel

**RELATED PRODUCTS**

- Programming Unit (model: PU-2x)
- PC configurator software (model: JXCON)

Downloadable at our web site.

A dedicated cable is required to connect the module to the PC. Please refer to the internet software download site or the users manual for the PC configurator for applicable cable types.

**GENERAL SPECIFICATIONS**

**Construction:** Plug-in

**Connection:** M3.5 screw terminals

**Screw terminal:** Chromated steel (standard) or stainless steel

**Housing material:** Flame-resistant resin (black)

**Isolation:** Input to output to power

**Zero adjustment:** -5 to +5 % (front)

**Span adjustment:** 95 to 105 % (front)

**Linearization:** 16 points max. within the range of -15.00 - +115.00 % input or output; represented as percentage of full-scale

**Adjustments:** Programming Unit (model: PU-2x); linearization data (Unused resistance of the potentiometer's total resistance can be programmed with the linearization table.), zero and span, simulating output, etc. (Refer to the users manual of JXCON for the adjustments configurable with JXCON.)

**INPUT SPECIFICATIONS**

**Minimum span:** 25 % of total resistance (set with the Programming Unit [model: PU-2x] or PC configurator software [model: JXCON])

**Excitation:** 0.25 V DC

**OUTPUT SPECIFICATIONS**

■ **DC Current:** 0 - 20 mA DC

**Minimum span:** 1 mA

**Offset:** Max. 1.5 times span

**Load resistance:** Output drive 15 V max.

■ **DC Voltage:** -10 - +20 V DC

**Span:** Min. 5 mV, max. 20 V

**Offset:** Max. 1.5 times span

**Load resistance:** Output drive 1 mA max.; at  $\geq 0.5$  V

**INSTALLATION**

**Power input**

•**AC:** Operational voltage range: rating  $\pm 10$  %, 50/60  $\pm 2$  Hz, approx. 3 VA

•**DC:** Operational voltage range: rating  $\pm 10$  %, ripple 10 %p-p max., approx. 2 W (90 mA at 24 V)

**Operating temperature:** -5 to +55°C (23 to 131°F)

**Operating humidity:** 30 to 90 %RH (non-condensing)

**Mounting:** Surface or DIN rail

**Weight:** 350 g (0.77 lb)

**PERFORMANCE in percentage of span**

**Accuracy:**  $\pm 0.1$  % with segment gain  $\leq 1$  [ $\pm 0.1$  %  $\times$  gain] with segment gain  $> 1$

**Temp. coefficient:**  $\pm 0.015$  %/°C ( $\pm 0.008$  %/°F)

**Response time:**  $\leq 0.5$  sec. (0 - 90 %)

**Line voltage effect:**  $\pm 0.1$  % over voltage range

**Insulation resistance:**  $\geq 100$  M $\Omega$  with 500 V DC

**Dielectric strength:** 2000 V AC @1 minute (input to output to power to ground)

## EXTERNAL DIMENSIONS & TERMINAL ASSIGNMENTS unit: mm [inch]

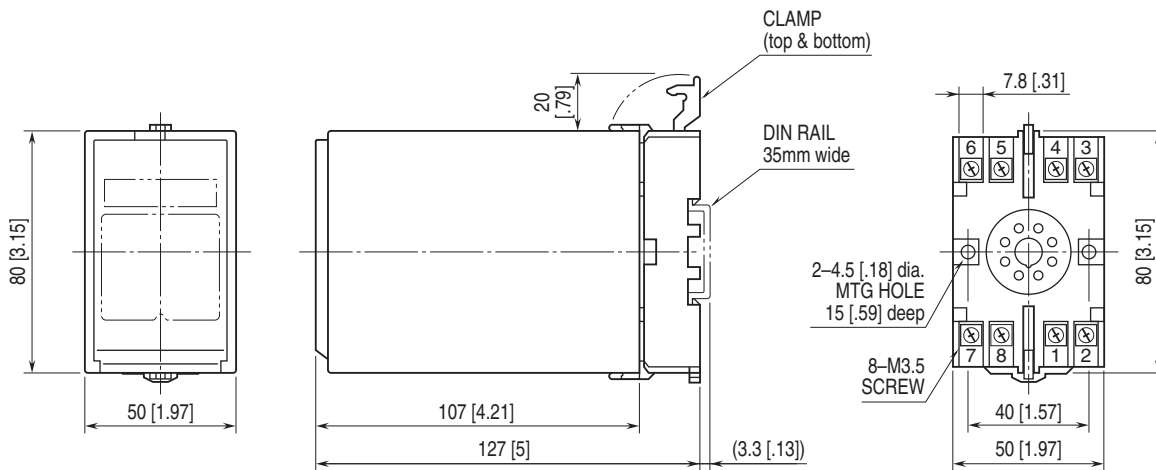

• When mounting, no extra space is needed between units.

## SCHEMATIC CIRCUITRY & CONNECTION DIAGRAM

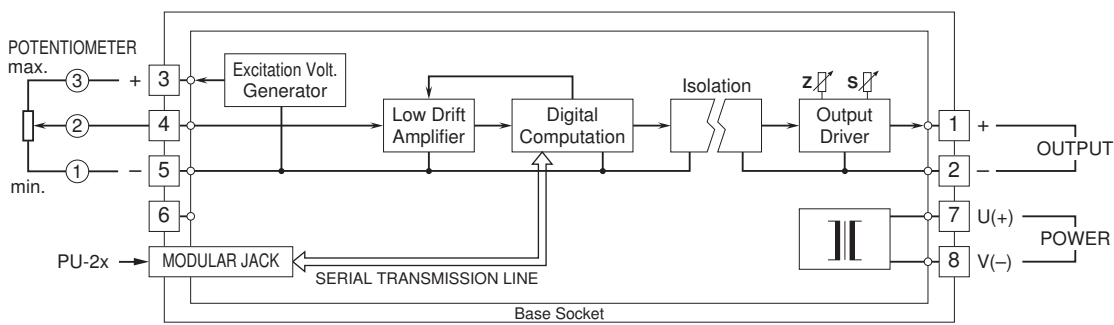

Specifications are subject to change without notice.