

## Plug-in Signal Conditioners M-UNIT

### RTD TRANSMITTER

(field-programmable)

#### Functions & Features

- Accepting direct input from an RTD and providing standard process signal
- Micro-processor based
- Field-programmable temperature range
- Linearization
- Burnout protection
- Isolation up to 2000 V AC
- Loop testing via hand-held programmer PU-2x
- High-density mounting

#### Typical Applications

- Ideal for quick spare part
- Power plant (2000 V AC isolation)

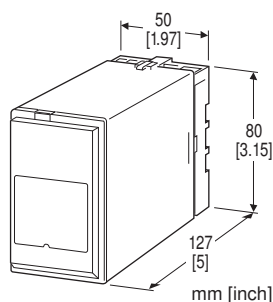

### MODEL: JR-[1][2]-[3][4]

#### ORDERING INFORMATION

- Code number: JR-[1][2]-[3][4]

Specify a code from below for each of [1] through [4].

- (e.g. JR-4A-B/BL/Q)
- Temperature range (e.g. 0 - 500°C)
- Special output range (For codes Z & 0)
- Specify the specification for option code /Q (e.g. /C01/S01)

#### [1] INPUT RTD (2- or 3-wire)

**1:** JPt 100 (JIS'89)

(Usable range: -200 to +500°C, -328 to +932°F; min.span: 50°C, 90°F)

**3:** Pt 100 (JIS'89)

(Usable range: -200 to +650°C, -328 to +1202°F; min.span: 50°C, 90°F)

**4:** Pt 100 (JIS'97, IEC)

(Usable range: -200 to +650°C, -328 to +1202°F; min.span: 50°C, 90°F)

**5:** Pt 50 Ω (JIS'81)

(Usable range: -200 to +500°C, -328 to +932°F; min.span: 100°C, 180°F)

**6:** Ni 508.4 Ω

(Usable range: -50 to +200°C, -58 to +392°F; min.span: 30°C, 54°F)

**0:** Specify

Note: Consult us for 2-wire RTD

#### [2] OUTPUT

Current

**A:** 4 - 20 mA DC (Load resistance 750 Ω max.)

**B:** 2 - 10 mA DC (Load resistance 1500 Ω max.)

**C:** 1 - 5 mA DC (Load resistance 3000 Ω max.)

**D:** 0 - 20 mA DC (Load resistance 750 Ω max.)

**E:** 0 - 16 mA DC (Load resistance 900 Ω max.)

**F:** 0 - 10 mA DC (Load resistance 1500 Ω max.)

**G:** 0 - 1 mA DC (Load resistance 15 kΩ max.)

**Z:** Specify current (See OUTPUT SPECIFICATIONS)

Voltage

**1:** 0 - 10 mV DC (Load resistance 10 kΩ min.)

**2:** 0 - 100 mV DC (Load resistance 100 kΩ min.)

**3:** 0 - 1 V DC (Load resistance 1000 Ω min.)

**4:** 0 - 10 V DC (Load resistance 10 kΩ min.)

**5:** 0 - 5 V DC (Load resistance 5000 Ω min.)

**6:** 1 - 5 V DC (Load resistance 5000 Ω min.)

**0:** Specify voltage (See OUTPUT SPECIFICATIONS)

#### [3] POWER INPUT

AC Power

**B:** 100 V AC

**C:** 110 V AC

**D:** 115 V AC

**F:** 120 V AC

**G:** 200 V AC

**H:** 220 V AC

**J:** 240 V AC

DC Power

**S:** 12 V DC

**R:** 24 V DC

**V:** 48 V DC

#### [4] OPTIONS (multiple selections)

Burnout

**blank:** Upscale burnout

**/BL:** Downscale burnout

Other Options

**blank:** none

**/Q:** Option other than the above (specify the specification)

**SPECIFICATIONS OF OPTION: Q (multiple selections)**

COATING (For the detail, refer to our web site.)

/C01: Silicone coating

/C02: Polyurethane coating

/C03: Rubber coating

TERMINAL SCREW MATERIAL

/S01: Stainless steel

**RELATED PRODUCTS**

- Programming Unit (model: PU-2x)
- PC configurator software (model: JXCON)

Downloadable at our web site.

A dedicated cable is required to connect the module to the PC. Please refer to the internet software download site or the users manual for the PC configurator for applicable cable types.

**GENERAL SPECIFICATIONS**

**Construction:** Plug-in

**Connection:** M3.5 screw terminals

**Screw terminal:** Chromated steel (standard) or stainless steel

**Housing material:** Flame-resistant resin (black)

**Isolation:** Input to output to power

**Overrange output:** Approx. -10 to +120 % at 1 - 5 V

**Zero adjustment:** -5 to +5 % (front)

**Span adjustment:** 95 to 105 % (front)

**Linearization:** Standard

**Adjustments:** Programming Unit (model: PU-2x);  
(Refer to the users manual of JXCON for the adjustments configurable with JXCON.)

- RTD type (between Pt 100 and JPt 100 only)
- temp. range
- zero and span
- simulating output
- Others

**INPUT SPECIFICATIONS**

**Maximum leadwire resistance:** 20  $\Omega$  per wire (3-wire)

**Sensing current:** 2 mA (Pt)

If not specified, the input range is shown below.

1: JPt 100 (JIS '89) 0 - 100°C

3: Pt 100 (JIS '89) 0 - 100°C

4: Pt 100 (JIS '97, IEC) 0 - 100°C

5: Pt 50  $\Omega$  (JIS '81) 0 - 200°C

6: Ni 508.4  $\Omega$  0 - 100°C

**OUTPUT SPECIFICATIONS**

■ **DC Current:** 0 - 20 mA DC

**Minimum span:** 1 mA

**Offset:** Max. 1.5 times span

**Load resistance:** Output drive 15 V max.

■ **DC Voltage:** -10 - +20 V DC

**Span:** Min. 5 mV, max. 20 V

**Offset:** Max. 1.5 times span

**Load resistance:** Output drive 1 mA max.; at  $\geq 0.5$  V

**INSTALLATION**

**Power input**

• **AC:** Operational voltage range: rating  $\pm 10$  %, 50/60  $\pm 2$  Hz, approx. 3 VA

• **DC:** Operational voltage range: rating  $\pm 10$  %, ripple 10 %p-p max., approx. 2 W (90 mA at 24 V)

**Operating temperature:** -5 to +55°C (23 to 131°F)

**Operating humidity:** 30 to 90 %RH (non-condensing)

**Mounting:** Surface or DIN rail

**Weight:** 350 g (0.77 lb)

**PERFORMANCE in percentage of span**

**Accuracy:**  $\pm 0.1$  % or  $\pm 0.1^\circ\text{C}$  ( $\pm 0.18^\circ\text{F}$ ), whichever is greater

**Temp. coefficient:**  $\pm 0.015$  %/ $^\circ\text{C}$  ( $\pm 0.008$  %/ $^\circ\text{F}$ )

**Response time:**  $\leq 0.5$  sec. (0 - 90 %)

**Burnout response:**  $\leq 10$  sec.

**Line voltage effect:**  $\pm 0.1$  % over voltage range

**Insulation resistance:**  $\geq 100$  M $\Omega$  with 500 V DC

**Dielectric strength:** 2000 V AC @1 minute (input to output to power to ground)

## EXTERNAL DIMENSIONS & TERMINAL ASSIGNMENTS unit: mm [inch]

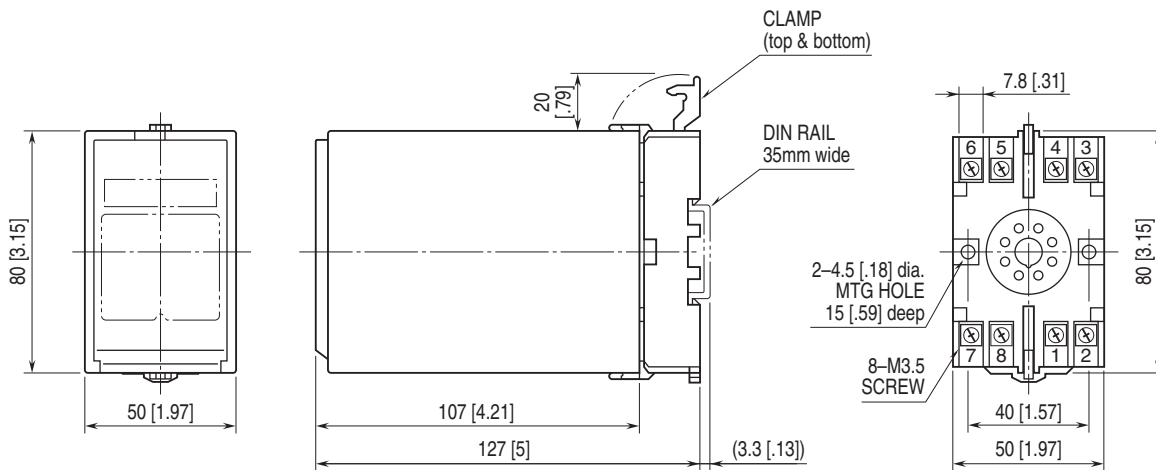

• When mounting, no extra space is needed between units.

## SCHEMATIC CIRCUITRY & CONNECTION DIAGRAM

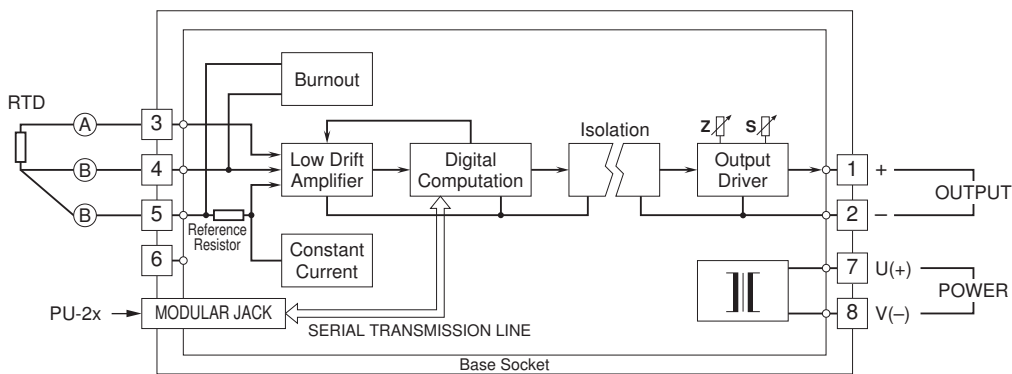

Specifications are subject to change without notice.