

## Plug-in Signal Conditioners M-UNIT

### SELF-SYNCH TRANSMITTER

(field-programmable)

#### Functions & Features

- Converting position signal from a self-synchronizing motor into DC signal proportional to the rotating shaft position
- Micro-processor based
- Linearization
- Loop testing via hand-held programmer PU-2x
- Offset adjustable via front multi-turn screwdriver adjustment
- High-density mounting

#### Typical Applications

- Position indicator using self-synch
- Tank gauge
- Sounding level meter

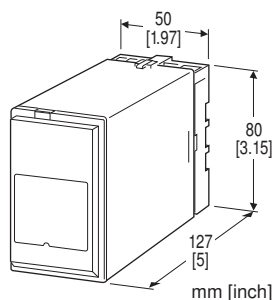

### MODEL: JS-1[1]-[2][3]

#### ORDERING INFORMATION

- Code number: JS-1[1]-[2][3]

Specify a code from below for each of [1] through [3].

- (e.g. JS-1A-B/Q)
- Input range (e.g. 270°)
- Special output ranges (For codes Z & 0)
- Linearization data (max. 16 points)

Use Ordering Information Sheet (No. ESU-1669) to specify linearization data when the I/O signals are nonlinear.

- Specify the specification for option code /Q (e.g. /C01/S01)

#### INPUT

1: Self-synch signal

#### [1] OUTPUT

Current

A: 4 - 20 mA DC (Load resistance 750 Ω max.)

B: 2 - 10 mA DC (Load resistance 1500 Ω max.)

C: 1 - 5 mA DC (Load resistance 3000 Ω max.)

D: 0 - 20 mA DC (Load resistance 750 Ω max.)

E: 0 - 16 mA DC (Load resistance 900 Ω max.)

F: 0 - 10 mA DC (Load resistance 1500 Ω max.)

G: 0 - 1 mA DC (Load resistance 15 kΩ max.)

Z: Specify current (See OUTPUT SPECIFICATIONS)

Voltage

1: 0 - 10 mV DC (Load resistance 10 kΩ min.)

2: 0 - 100 mV DC (Load resistance 100 kΩ min.)

3: 0 - 1 V DC (Load resistance 1000 Ω min.)

4: 0 - 10 V DC (Load resistance 10 kΩ min.)

5: 0 - 5 V DC (Load resistance 5000 Ω min.)

6: 1 - 5 V DC (Load resistance 5000 Ω min.)

4W: -10 - +10 V DC (Load resistance 10 kΩ min.)

5W: -5 - +5 V DC (Load resistance 5000 Ω min.)

0: Specify voltage (See OUTPUT SPECIFICATIONS)

#### [2] POWER INPUT

AC Power

B: 100 V AC

C: 110 V AC

D: 115 V AC

F: 120 V AC

G: 200 V AC

H: 220 V AC

J: 240 V AC

#### [3] OPTIONS

blank: none

/Q: With options (specify the specification)

#### SPECIFICATIONS OF OPTION: Q (multiple selections)

COATING (For the detail, refer to our web site.)

/C01: Silicone coating

/C02: Polyurethane coating

/C03: Rubber coating

TERMINAL SCREW MATERIAL

/S01: Stainless steel

#### RELATED PRODUCTS

- Programming Unit (model: PU-2x)
- PC configurator software (model: JXCON)

Downloadable at our web site.

A dedicated cable is required to connect the module to the PC. Please refer to the internet software download site or the users manual for the PC configurator for applicable cable types.

**GENERAL SPECIFICATIONS**

**Construction:** Plug-in  
**Connection:** M3.5 screw terminals  
**Screw terminal:** Chromated steel (standard) or stainless steel  
**Housing material:** Flame-resistant resin (black)  
**Isolation:** Input to output to power  
**Offset adjustment:** 0 to 360°(front)  
**Zero adjustment:** -5 to +5 % (front)  
**Span adjustment:** 95 to 105 % (front)  
**Linearization:** 16 points max. within the range of -15.00 - +115.00 % input or output; represented as percentage of full-scale  
**Adjustments:** Programming Unit (model: PU-2x); input range, offset, linearization data, zero and span, input angle & coordinates, etc.  
(Refer to the users manual of JXCON for the adjustments configurable with JXCON.)

**Line voltage effect:**  $\pm 0.1$  % over voltage range  
**Insulation resistance:**  $\geq 100$  M $\Omega$  with 500 V DC  
**Dielectric strength:** 2000 V AC @1 minute (input to output to power to ground)

**INPUT SPECIFICATIONS**

**Input:** Self-synch signal  
**Measurement range:** 0 - 360°  
**Input range:** 60 - 360° (270° for default)  
**Input resistance:** 1 M $\Omega$  min.  
**Rated input voltage:** 90 V AC

**OUTPUT SPECIFICATIONS**

■ **DC Current:** 0 - 20 mA DC  
**Minimum span:** 1 mA  
**Offset:** Max. 1.5 times span  
**Load resistance:** Output drive 15 V max.  
■ **DC Voltage:** -10 - +20 V DC  
**Span:** Min. 5 mV, max. 20 V  
**Offset:** Max. 1.5 times span  
**Load resistance:** Output drive 1 mA max.; at  $\geq 0.5$  V

**INSTALLATION**

**Power input**  
• **AC:** Operational voltage range: rating  $\pm 10$  %, 50/60  $\pm 2$  Hz, approx. 3 VA  
**Operating temperature:** -5 to +55°C (23 to 131°F)  
**Operating humidity:** 30 to 90 %RH (non-condensing)  
**Mounting:** Surface or DIN rail  
**Weight:** 350 g (0.77 lb)

**PERFORMANCE in percentage of span**

**Accuracy:**  $\pm 0.2$  % or  $\pm 0.5^\circ$ , whichever is greater (gain  $\leq 1$ )  
accuracy =  $[\pm 0.2 \text{ } (\pm 0.5^\circ) \times \text{gain}]$  with the gain  $> 1$   
**Temp. coefficient:**  $\pm 0.015$  %/°C ( $\pm 0.008$  %/°F)  
**Response time:** Approx. 2 sec. (0 - 90 %)

## EXTERNAL VIEW

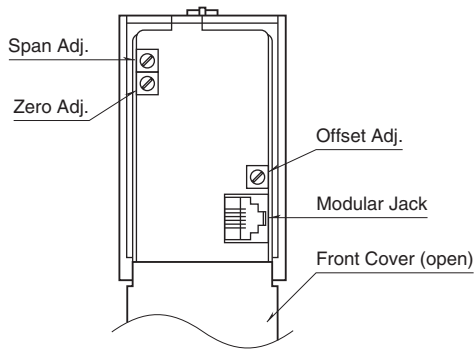

## EXTERNAL DIMENSIONS & TERMINAL ASSIGNMENTS unit: mm [inch]

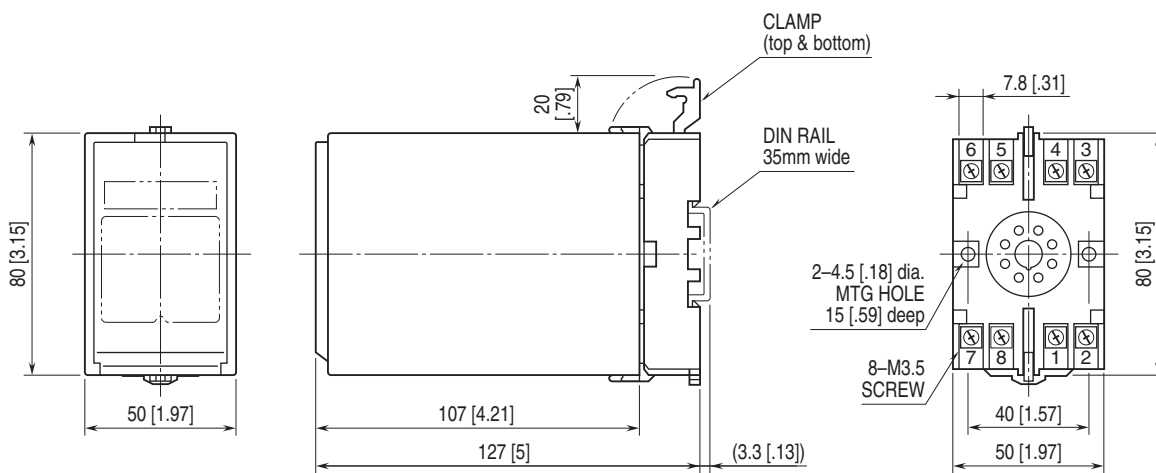

• When mounting, no extra space is needed between units.

## SCHEMATIC CIRCUITRY & CONNECTION DIAGRAM

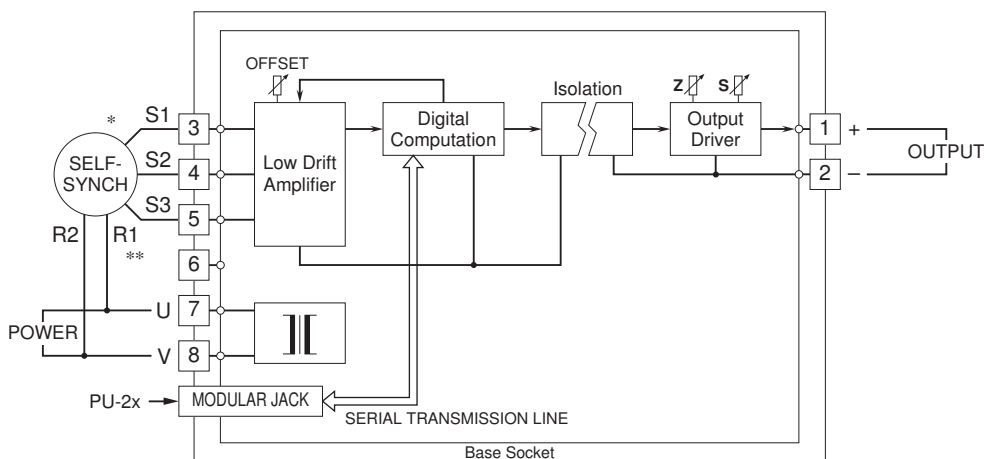

\* The output increases when the self-synch rotates clockwise. For changing the operation to counterclockwise, replace the connection of the S2 and S3.

\*\*Be sure that the polarity of the power input to the JS matches to the self-synch input polarity. When the connection is reversed, the JS output will be shifted by 180°.



Specifications are subject to change without notice.