

Plug-in Signal Conditioners K-UNIT

FREQUENCY TRANSDUCER

Functions & Features

- Providing a DC output signal in proportion to deviation (± 5 Hz) from center frequency (50 Hz or 60 Hz)
- DC output containing little ripple is ideal for computer input
- Isolation up to 2000 V AC
- High-density mounting

Typical Applications

- Centralized monitoring and control of power management system in manufacturing facility or building
- Measuring frequency for UPS

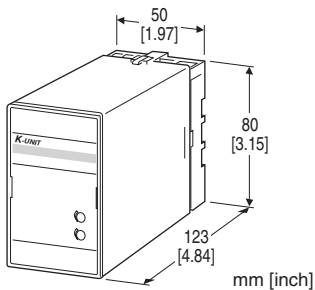

MODEL: KEHZ-[1][2][3]-[4][5]

ORDERING INFORMATION

- Code number: KEHZ-[1][2][3]-[4][5]
- Specify a code from below for each of [1] through [5].
(e.g. KEHZ-11A-C/Q)
- Special output range (For codes Z & 0)
- Specify the specification for option code /Q
(e.g. /C01/S01)

[1] FREQUENCY

- 1: 45 - 55 Hz
- 2: 55 - 65 Hz
- 3: 45 - 65 Hz

[2] INPUT

- 1: 110 V AC
- 2: 220 V AC

[3] OUTPUT

Current

- A: 4 - 20 mA DC (Load resistance 600 Ω max.)
- D: 0 - 20 mA DC (Load resistance 600 Ω max.)

- E: 0 - 16 mA DC (Load resistance 750 Ω max.)
 - F: 0 - 10 mA DC (Load resistance 1200 Ω max.)
 - G: 0 - 1 mA DC (Load resistance 12 k Ω max.)
 - J: 0 - 5 mA DC (Load resistance 2400 Ω max.)
 - Z: Specify current (See OUTPUT SPECIFICATIONS)
- Voltage
- 1: 0 - 10 mV DC (Load resistance 10 k Ω min.)
 - 2: 0 - 100 mV DC (Load resistance 100 k Ω min.)
 - 3: 0 - 1 V DC (Load resistance 1000 Ω min.)
 - 4: 0 - 10 V DC (Load resistance 10 k Ω min.)
 - 5: 0 - 5 V DC (Load resistance 5000 Ω min.)
 - 6: 1 - 5 V DC (Load resistance 5000 Ω min.)
 - 0: Specify voltage (See OUTPUT SPECIFICATIONS)

[4] AUXILIARY POWER SUPPLY

AC Power

- B: 100 V AC
 - C: 110 V AC
 - D: 115 V AC
 - F: 120 V AC
 - G: 200 V AC
 - H: 220 V AC
 - J: 240 V AC
- DC Power
- R: 24 V DC
 - V: 48 V DC
 - P: 110 V DC

[5] OPTIONS

- blank: none
- /Q: With options (specify the specification)

SPECIFICATIONS OF OPTION: Q (multiple selections)

COATING (For the detail, refer to our web site.)

- /C01: Silicone coating
- /C02: Polyurethane coating
- /C03: Rubber coating

TERMINAL SCREW MATERIAL

- /S01: Stainless steel

GENERAL SPECIFICATIONS

Construction: Plug-in

Connection: M3.5 screw terminals

Screw terminal: Chromated steel (standard) or stainless steel

Housing material: Flame-resistant resin (black)

Isolation: Input to output to auxiliary power

Computation: One-shot

Overrange output: Approx. -10 to +120 % at 1 - 5 V

Zero adjustment: -5 to +5 % (front)

Span adjustment: 95 to 105 % (front)

INPUT SPECIFICATIONS

Input burden: 1 VA

Overload capacity: 150 % of rating for 10 sec., 120 % continuous

Operational range: 85 - 120 % of rating

OUTPUT SPECIFICATIONS

■ **DC Current:** 0 - 20 mA DC

Minimum span: 1 mA

Offset: Max. 1.5 times span

Load resistance: Output drive 12 V max.

■ **DC Voltage:** 0 - 12 V DC

Minimum span: 5 mV

Offset: Max. 1.5 times span

Load resistance: Output drive 1 mA max.; at ≥ 0.5 V

■ **OPERATION DIAGRAM (example)**

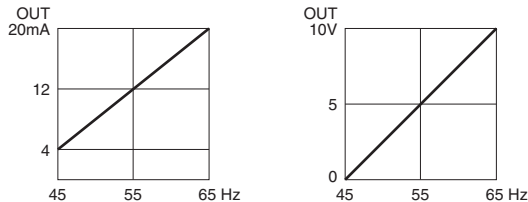

Note: When there is no input voltage, the transducer outputs as negative (-) overrange.

INSTALLATION

Auxiliary power supply

• **AC:** Operational voltage range: rating $-15/+10$ %, 50/60 Hz, approx. 2 VA

• **DC:** Operational voltage range: rating ± 10 %, or 85 - 150 V for 110 V rating, ripple 10 %p-p max., approx. 2 W (18 mA at 110 V)

Operating temperature: -10 to $+55^{\circ}\text{C}$ (14 to 131°F)

Operating humidity: 30 to 85 %RH (non-condensing)

Mounting: Surface or DIN rail

Weight: 300 g (0.66 lb)

PERFORMANCE in percentage of span

Accuracy: ± 1 % (at $23^{\circ}\text{C} \pm 10^{\circ}\text{C}$ or $73.4^{\circ}\text{F} \pm 18^{\circ}\text{F}$)

Response time: ≤ 1 sec. (0 - 100 % ± 1 %)

Ripple: 0.5 %p-p max.

Line voltage effect: ± 0.1 % over voltage range

Insulation resistance: ≥ 100 M Ω with 500 V DC

Dielectric strength: 2000 V AC @1 minute (input to output to auxiliary power to ground)

Impulse withstand voltage: 1.2 / 50 $\mu\text{sec.}$, ± 5 kV (input to output or ground)

CONNECTION DIAGRAM

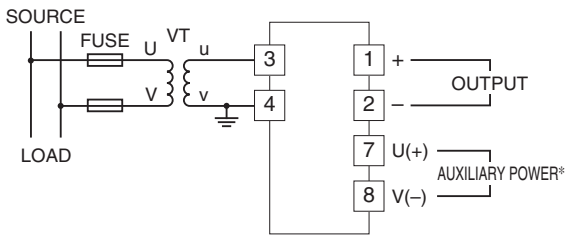

* The transducer can be powered from the input voltage when the voltage is sufficiently stable and meets within the range of auxiliary power supply of the unit specified in the data sheet/instruction manual.

EXTERNAL DIMENSIONS & TERMINAL ASSIGNMENTS unit: mm [inch]

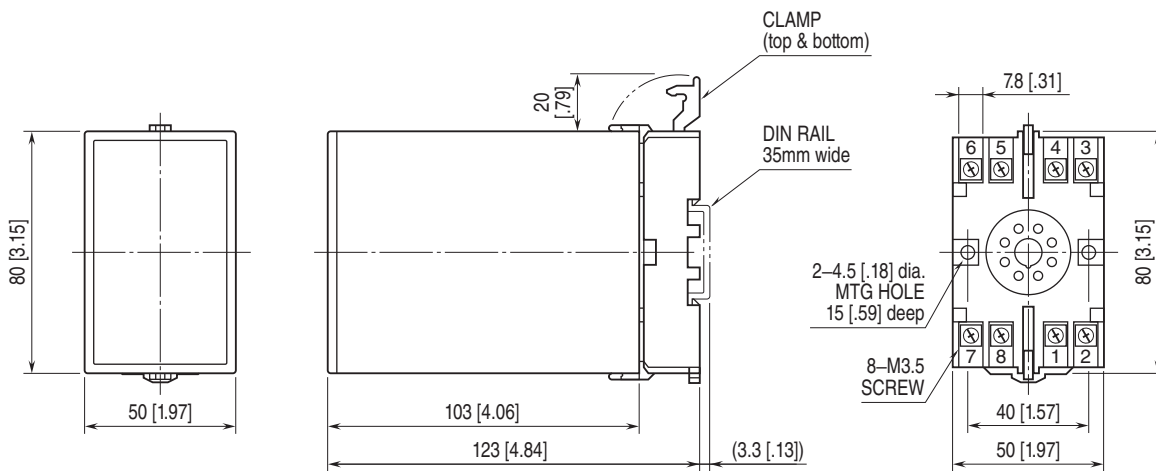

• When mounting, no extra space is needed between units.



Specifications are subject to change without notice.