

## Plug-in Signal Conditioners K-UNIT

### TACHOGENERATOR TRANSMITTER

#### Functions & Features

- Converting an AC voltage from a tachogenerator (tachometer) into a standard process signal
- Wide input range
- Isolation up to 2000 V AC
- High-density mounting

#### Typical Applications

- Measuring rotating or moving speed of multispeed motors, belt conveyers, metering pumps

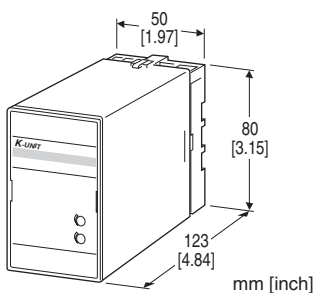

### MODEL: KTG-[1][2]-[3][4]

#### ORDERING INFORMATION

- Code number: KTG-[1][2]-[3][4]
- Specify a code from below for each of [1] through [4].  
(e.g. KTG-AA-B/Q)
- Special input and output ranges (For codes U, Z & 0)
  - Specify the specification for option code /Q  
(e.g. /C01/S01)

#### [1] INPUT

##### Voltage

- 1: 0 - 35 V AC (Input resistance 100 kΩ min.)
- 2: 0 - 50 mV AC (Input resistance 100 kΩ min.)
- 3: 0 - 60 mV AC (Input resistance 100 kΩ min.)
- 4: 0 - 100 mV AC (Input resistance 100 kΩ min.)
- 5: 0 - 1 V AC (Input resistance 100 kΩ min.)
- 6: 0 - 10 V AC (Input resistance 100 kΩ min.)
- 7: 0 - 100 V AC (Input resistance 100 kΩ min.)
- 8: 0 - 110 V AC (Input resistance 100 kΩ min.)
- 9: 0 - 150 V AC (Input resistance 100 kΩ min.)
- A: 0 - 200 V AC (Input resistance 100 kΩ min.)
- B: 0 - 250 V AC (Input resistance 100 kΩ min.)
- U: Specify voltage (See INPUT SPECIFICATIONS)  
(0 % input must be 0 V.)

#### [2] OUTPUT

##### Current

- A: 4 - 20 mA DC (Load resistance 750 Ω max.)
- B: 2 - 10 mA DC (Load resistance 1500 Ω max.)
- C: 1 - 5 mA DC (Load resistance 3000 Ω max.)
- D: 0 - 20 mA DC (Load resistance 750 Ω max.)
- E: 0 - 16 mA DC (Load resistance 900 Ω max.)
- F: 0 - 10 mA DC (Load resistance 1500 Ω max.)
- G: 0 - 1 mA DC (Load resistance 15 kΩ max.)
- Z: Specify current (See OUTPUT SPECIFICATIONS)

##### Voltage

- 1: 0 - 10 mV DC (Load resistance 10 kΩ min.)
- 2: 0 - 100 mV DC (Load resistance 100 kΩ min.)
- 3: 0 - 1 V DC (Load resistance 100 Ω min.)
- 4: 0 - 10 V DC (Load resistance 1000 Ω min.)
- 5: 0 - 5 V DC (Load resistance 500 Ω min.)
- 6: 1 - 5 V DC (Load resistance 500 Ω min.)
- 4W: -10 - +10 V DC (Load resistance 2000 Ω min.)
- 5W: -5 - +5 V DC (Load resistance 1000 Ω min.)
- 0: Specify voltage (See OUTPUT SPECIFICATIONS)

#### [3] POWER INPUT

##### AC Power

- B: 100 V AC
- C: 110 V AC
- D: 115 V AC
- F: 120 V AC
- G: 200 V AC
- H: 220 V AC
- J: 240 V AC

##### DC Power

- S: 12 V DC
- R: 24 V DC

#### [4] OPTIONS

blank: none

/Q: With options (specify the specification)

#### SPECIFICATIONS OF OPTION: Q (multiple selections)

COATING (For the detail, refer to our web site.)

/C01: Silicone coating

/C02: Polyurethane coating

/C03: Rubber coating

TERMINAL SCREW MATERIAL

/S01: Stainless steel

#### GENERAL SPECIFICATIONS

Construction: Plug-in

Connection: M3.5 screw terminals

Screw terminal: Chromated steel (standard) or stainless

steel

**Housing material:** Flame-resistant resin (black)

**Isolation:** Input to output to power

**Overrange output:** 0 to 120 % at 1 - 5 V

**Zero adjustment:** -5 to +5 % (front)

**Span adjustment:** 95 to 105 % (front)

## INPUT SPECIFICATIONS

• **AC Voltage:** 0 - 250 V AC

**Minimum span:** 50 mV

**Frequency:** 15 Hz min., 1 kHz max. with 100 % input

**Input resistance:**  $\geq 100 \text{ k}\Omega$

## OUTPUT SPECIFICATIONS

■ **DC Current:** 0 - 20 mA DC

**Minimum span:** 1 mA

**Offset:** Max. 1.5 times span

**Load resistance:** Output drive 15 V max.

■ **DC Voltage:** -10 - +12 V DC

**Minimum span:** 5 mV

**Offset:** Max. 1.5 times span

**Load resistance:** Output drive 10 mA max.; 5 mA for negative voltage output; at  $\geq 0.5 \text{ V}$

## INSTALLATION

**Power input**

• **AC:** Operational voltage range: rating  $\pm 10 \%$ ,  
50/60  $\pm 2$  Hz, approx. 2 VA

• **DC:** Operational voltage range: rating  $\pm 10 \%$ ,  
ripple 10 %p-p max., approx. 2 W (80 mA at 24 V)

**Operating temperature:** -5 to +55°C (23 to 131°F)

**Operating humidity:** 30 to 90 %RH (non-condensing)

**Mounting:** Surface or DIN rail

**Weight:** 450 g (0.99 lb)

## PERFORMANCE in percentage of span

**Accuracy:**  $\pm 0.4 \%$

**Temp. coefficient:**  $\pm 0.05 \%/^{\circ}\text{C}$  ( $\pm 0.03 \%/^{\circ}\text{F}$ )

**Response time:**  $\leq 0.7 \text{ sec.}$  (0 - 90 %)

**Ripple:** 0.5 %p-p max.

**Line voltage effect:**  $\pm 0.1 \%$  over voltage range

**Insulation resistance:**  $\geq 100 \text{ M}\Omega$  with 500 V DC

**Dielectric strength:** 2000 V AC @1 minute (input to output to power to ground)

**EXTERNAL DIMENSIONS & TERMINAL ASSIGNMENTS unit: mm [inch]**

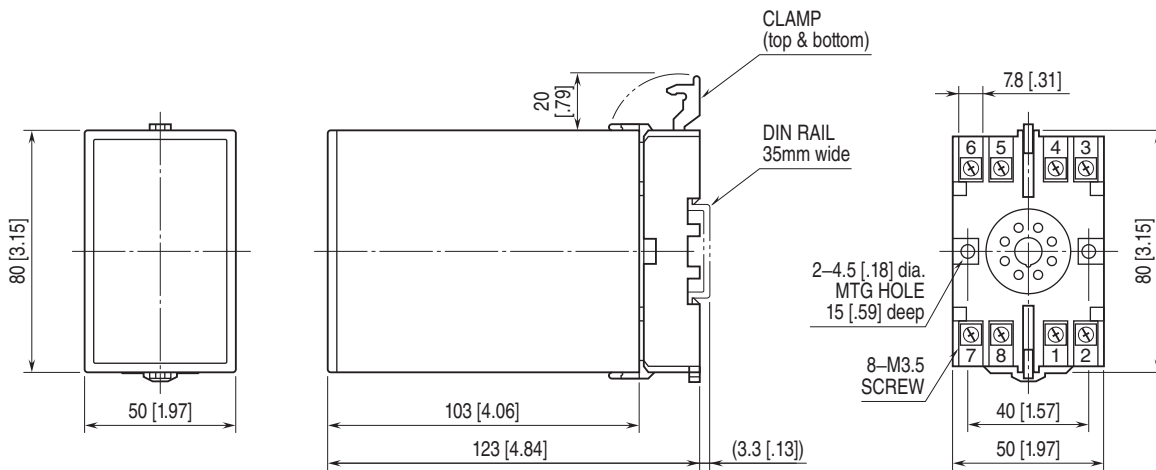

• When mounting, no extra space is needed between units.

**SCHEMATIC CIRCUITRY & CONNECTION DIAGRAM**

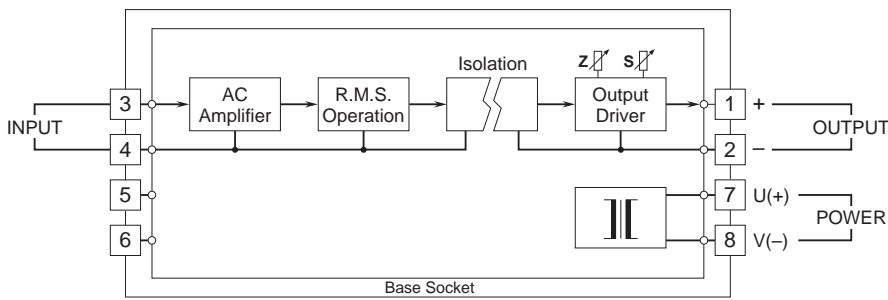

Specifications are subject to change without notice.