

Plug-in Signal Conditioners K-UNIT

SIGNAL TRANSMITTER

(two isolated outputs)

Functions & Features

- Converting a DC input into two standard process signals
- Fast response type available
- High-density mounting

Typical Applications

- Isolation between control room and field instrumentation

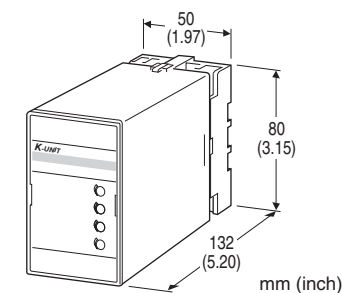

MODEL: KWVS-[1][2][3]-[4][5]

ORDERING INFORMATION

- Code number: KWVS-[1][2][3]-[4][5]

Specify a code from below for each of [1] through [5].

- (e.g. KWVS-6AA-B/K/Q)
- Special input and output ranges (For codes Z & 0)
- Specify the specification for option code /Q (e.g. /C01/S01)

Note: When the user requires a current and a voltage output, specify the current to be the Output 1 which allows a greater load.

[1] INPUT

Current

- A:** 4 - 20 mA DC (Input resistance 250 Ω)
- A1:** 4 - 20 mA DC (Input resistance 50 Ω)
- B:** 2 - 10 mA DC (Input resistance 500 Ω)
- C:** 1 - 5 mA DC (Input resistance 1000 Ω)
- D:** 0 - 20 mA DC (Input resistance 50 Ω)
- E:** 0 - 16 mA DC (Input resistance 62.5 Ω)
- F:** 0 - 10 mA DC (Input resistance 100 Ω)
- G:** 0 - 1 mA DC (Input resistance 1000 Ω)
- H:** 10 - 50 mA DC (Input resistance 100 Ω)
- J:** 0 - 10 μA DC (Input resistance 1000 Ω)
- K:** 0 - 100 μA DC (Input resistance 1000 Ω)
- GW:** -1 - +1 mA DC (Input resistance 1000 Ω)
- FW:** -10 - +10 mA DC (Input resistance 100 Ω)

Z: Specify current (See INPUT SPECIFICATIONS)
Voltage

- 1:** 0 - 10 mV DC (Input resistance 10 kΩ min.)
- 15:** 0 - 50 mV DC (Input resistance 10 kΩ min.)
- 16:** 0 - 60 mV DC (Input resistance 10 kΩ min.)
- 2:** 0 - 100 mV DC (Input resistance 100 kΩ min.)
- 3:** 0 - 1 V DC (Input resistance 1 MΩ min.)
- 4:** 0 - 10 V DC (Input resistance 1 MΩ min.)
- 5:** 0 - 5 V DC (Input resistance 1 MΩ min.)
- 6:** 1 - 5 V DC (Input resistance 1 MΩ min.)
- 4W:** -10 - +10 V DC (Input resistance 1 MΩ min.)
- 5W:** -5 - +5 V DC (Input resistance 1 MΩ min.)
- 0:** Specify voltage (See INPUT SPECIFICATIONS)

[2] OUTPUT 1

Current

- A:** 4 - 20 mA DC (Load resistance 600 Ω max.)
- B:** 2 - 10 mA DC (Load resistance 1200 Ω max.)
- C:** 1 - 5 mA DC (Load resistance 2400 Ω max.)
- D:** 0 - 20 mA DC (Load resistance 600 Ω max.)
- E:** 0 - 16 mA DC (Load resistance 750 Ω max.)
- F:** 0 - 10 mA DC (Load resistance 1200 Ω max.)
- G:** 0 - 1 mA DC (Load resistance 12 kΩ max.)
- Z:** Specify current (See OUTPUT SPECIFICATIONS)

Voltage

- 1:** 0 - 10 mV DC (Load resistance 10 kΩ min.)
- 2:** 0 - 100 mV DC (Load resistance 100 kΩ min.)
- 3:** 0 - 1 V DC (Load resistance 1000 Ω min.)
- 4:** 0 - 10 V DC (Load resistance 10 kΩ min.)
- 5:** 0 - 5 V DC (Load resistance 5000 Ω min.)
- 6:** 1 - 5 V DC (Load resistance 5000 Ω min.)
- 4W:** -10 - +10 V DC (Load resistance 10 kΩ min.)
- 5W:** -5 - +5 V DC (Load resistance 5000 Ω min.)
- 0:** Specify voltage (See OUTPUT SPECIFICATIONS)

[3] OUTPUT 2

Current

- A:** 4 - 20 mA DC (Load resistance 350 Ω max.)
- B:** 2 - 10 mA DC (Load resistance 700 Ω max.)
- C:** 1 - 5 mA DC (Load resistance 1400 Ω max.)
- D:** 0 - 20 mA DC (Load resistance 350 Ω max.)
- E:** 0 - 16 mA DC (Load resistance 430 Ω max.)
- F:** 0 - 10 mA DC (Load resistance 700 Ω max.)
- G:** 0 - 1 mA DC (Load resistance 7000 Ω max.)
- Z:** Specify current (See OUTPUT SPECIFICATIONS)

Voltage

Same range availability as Output 1

[4] POWER INPUT

AC Power

- B:** 100 V AC

C: 110 V AC
D: 115 V AC
F: 120 V AC
G: 200 V AC
H: 220 V AC
J: 240 V AC
 DC Power
S: 12 V DC
R: 24 V DC

[5] OPTIONS (multiple selections)

Response Time (0 - 90 %)
blank: Standard (≤ 0.5 sec.)
/K: Fast Response (Approx. 25 msec.)
 Other Options
blank: none
/Q: Option other than the above (specify the specification)

SPECIFICATIONS OF OPTION: Q (multiple selections)

COATING (For the detail, refer to our web site.)
/C01: Silicone coating
/C02: Polyurethane coating
/C03: Rubber coating
 TERMINAL SCREW MATERIAL
/S01: Stainless steel

GENERAL SPECIFICATIONS

Construction: Plug-in
Connection: M3.5 screw terminals
Screw terminal: Chromated steel (standard) or stainless steel
Housing material: Flame-resistant resin (black)
Isolation: Input to output 1 to output 2 to power
Overrange output: Approx. -10 to +120 % at 1 - 5 V
Zero adjustment: -5 to +5 % (front)
Span adjustment: 95 to 105 % (front)
 Adjustable individually for each output 1 and output 2.

INPUT SPECIFICATIONS

DC Current:
 Shunt resistor attached to the input terminals (0.5 W)
 Specify input resistance value for code Z.
DC Voltage: -300 - +300 V DC
Minimum span: 3 mV
Offset: Max. 1.5 times span
Input resistance
 Span 3 - 10 mV : ≥ 10 k Ω
 Span 10 - 100 mV : ≥ 10 k Ω
 Span 0.1 - 1 V : ≥ 100 k Ω
 Span ≥ 1 V : ≥ 1 M Ω

OUTPUT SPECIFICATIONS

DC Current: 0 - 20 mA DC
Minimum span: 1 mA
Offset: Max. 1.5 times span
Load resistance: Output drive 12 V max. for Output 1;
 7 V max. for Output 2
DC Voltage: -10 - +12 V DC
Minimum span: 5 mV
Offset: Max. 1.5 times span
Load resistance: Output drive 1 mA max. at ≥ 0.5 V

INSTALLATION

Power input
AC: Operational voltage range: rating ± 10 %, 50/60 ± 2 Hz, approx. 3 VA
DC: Operational voltage range: rating ± 10 % ripple 10 %p-p max., approx. 3 W (125 mA at 24 V)
Operating temperature: -5 to +55°C (23 to 131°F)
Operating humidity: 30 to 90 %RH (non-condensing)
Mounting: Surface or DIN rail
Weight: 400 g (0.88 lb)

PERFORMANCE in percentage of span

Accuracy: ± 0.1 %
Temp. coefficient: ± 0.02 %/°C (± 0.01 %/°F)
Line voltage effect: ± 0.1 % over voltage range
Insulation resistance: ≥ 100 M Ω with 500 V DC
Dielectric strength: 2000 V AC @1 minute
 (input to output to power to ground)
 1000 V AC @ 1 minute (output 1 to output 2)

EXTERNAL DIMENSIONS unit: mm [inch]

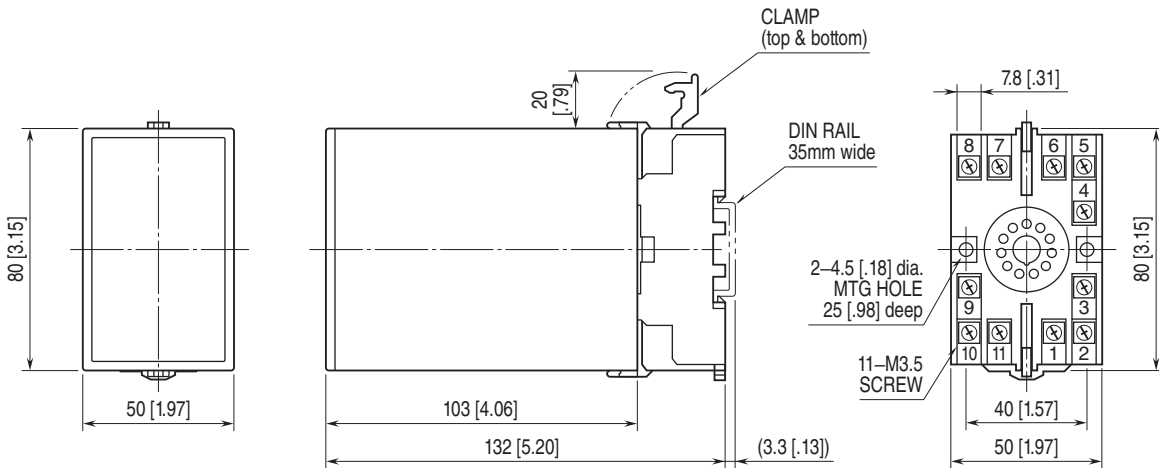

• When mounting, no extra space is needed between units.

TERMINAL ASSIGNMENTS unit: mm [inch]

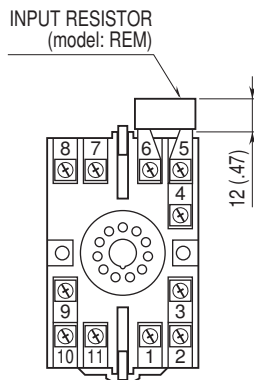

Input shunt resistor attached for current input.

SCHEMATIC CIRCUITRY & CONNECTION DIAGRAM

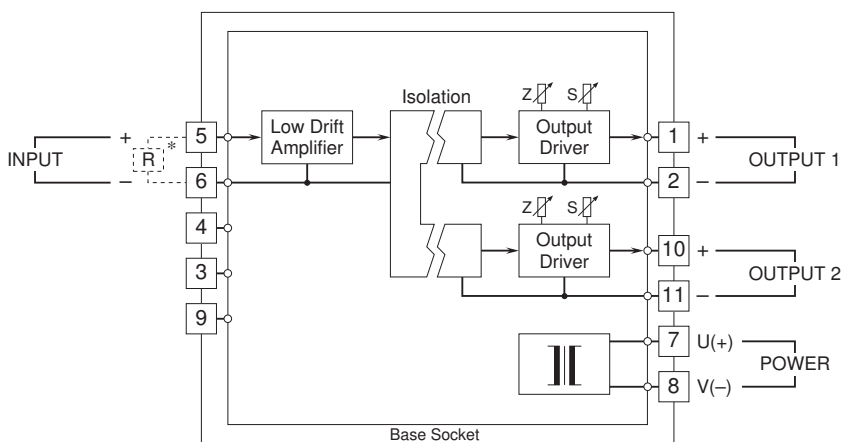

*Input shunt resistor attached for current input.



Specifications are subject to change without notice.