

Plug-in Signal Conditioners M-UNIT

STRAIN GAUGE TRANSMITTER

(remote sensing; isolated)

Functions & Features

- Provides a DC output signal compatible with a bridge type strain gauge utilized in load cells, pressure transducers
- Six-wire remote sensing compensates for lead resistance variations
- Excitation adjustable from 2 V to 5 V
- Wide-range adjustment: 0 - 80 % for zero, 100 - 20 % for span
- High-density mounting

Typical Applications

- Weighing system for tanks, hoppers, silos
- Weighing system using cranes
- Float level meter utilizing strain gauges

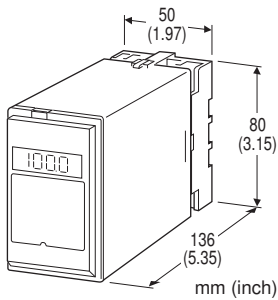

MODEL: LCS2-[1][2]-[3][4]

ORDERING INFORMATION

- Code number: LCS2-[1][2]-[3][4]
- Specify a code from below for each of [1] through [4].
(e.g. LCS2-2A-B/E/K/Q)
- Special output range (For codes Z & 0)
- Specify the specification for option code /Q
(e.g. /C01/S01)

[1] INPUT STRAIN GAUGE

- 1: 1 mV/V
- 12: 1.25 mV/V
- 15: 1.5 mV/V
- 2: 2 mV/V
- 3: 3 mV/V
- 4: 4 mV/V
- 5: 5 mV/V
- 6: 10 mV/V
- 7: 20 mV/V
- 0: Specify (strain gauge and excitation)

[2] OUTPUT

Current

- A: 4 - 20 mA DC (Load resistance 750 Ω max.)
- B: 2 - 10 mA DC (Load resistance 1500 Ω max.)
- C: 1 - 5 mA DC (Load resistance 3000 Ω max.)
- D: 0 - 20 mA DC (Load resistance 750 Ω max.)
- E: 0 - 16 mA DC (Load resistance 900 Ω max.)
- F: 0 - 10 mA DC (Load resistance 1500 Ω max.)
- G: 0 - 1 mA DC (Load resistance 15 kΩ max.)
- Z: Specify current (See OUTPUT SPECIFICATIONS)

Voltage

- 1: 0 - 10 mV DC (Load resistance 10 kΩ min.)
- 2: 0 - 100 mV DC (Load resistance 100 kΩ min.)
- 3: 0 - 1 V DC (Load resistance 100 Ω min.)
- 4: 0 - 10 V DC (Load resistance 1000 Ω min.)
- 5: 0 - 5 V DC (Load resistance 500 Ω min.)
- 6: 1 - 5 V DC (Load resistance 500 Ω min.)
- 4W: -10 - +10 V DC (Load resistance 2000 Ω min.)
- 5W: -5 - +5 V DC (Load resistance 1000 Ω min.)
- 0: Specify voltage (See OUTPUT SPECIFICATIONS)

[3] POWER INPUT

AC Power

- B: 100 V AC
- C: 110 V AC
- D: 115 V AC
- F: 120 V AC
- G: 200 V AC
- H: 220 V AC
- J: 240 V AC

DC Power

- R: 24 V DC

[4] OPTIONS (multiple selections)

Input Signal Indicator

- blank: Without
- /E: With (0.0 - 100.0 % display)
- Response Time (0 - 90 %)
- blank: Standard (≤ 0.5 sec.)
- /K: Fast Response (Approx. 25 msec.)

Other Options

- blank: none
- /Q: Option other than the above (specify the specification)

SPECIFICATIONS OF OPTION: Q (multiple selections)

COATING (For the detail, refer to our web site.)

- /C01: Silicone coating
- /C02: Polyurethane coating
- /C03: Rubber coating
- TERMINAL SCREW MATERIAL
- /S01: Stainless steel

GENERAL SPECIFICATIONS

Construction: Plug-in
Connection: M3.5 screw terminals
Screw terminal: Chromated steel (standard) or stainless steel
Housing material: Flame-resistant resin (black)
Isolation: Input to output to power
Overrange output: Approx. -10 to +120 % at 1 - 5 V
Excitation adjustment: 2 - 5 V (front) limited to ≤ 10 V when the remote sensing terminals are open.
Zero adjustments (tare): 0 - 80 % (front)
 (Excitation voltage: factory default)
Span adjustment: 100 - 20 % (front)
 (Excitation voltage: factory default)
■ DISPLAY (Input indicator)
LCD digital display: 0.0 - 100.0 % (min. digit 0.1 %)
 (No scaling)

INPUT SPECIFICATIONS

Input: Bridge voltage from load cells
Allowable leadwire resistance: \leq Total Strain Gauge Resistance $\times 0.25$
 • **Strain Gauge**
Rated output from strain gauge: 1 - 20 mV/V; Input to the transmitter must be over 3 mV.
 • **Excitation:** 2 - 5 V adjustable (5 V standard)
Maximum current: 65 mA

OUTPUT SPECIFICATIONS

■ DC Current: 0 - 20 mA DC
Minimum span: 1 mA
Offset: Max. 1.5 times span
Load resistance: Output drive 15 V max.
■ DC Voltage: -10 - +12 V DC
Minimum span: 5 mV
Offset: Max. 1.5 times span
Load resistance: Output drive 10 mA max.; 5 mA for negative voltage output; at ≥ 0.5 V

INSTALLATION

Power input
 • **AC:** Operational voltage range: rating ± 10 %, 50/60 ± 2 Hz, approx. 5 VA
 • **DC:** Operational voltage range: 24 V ± 10 %, approx. 150 mA, ripple 10 %p-p max.
Operating temperature: -5 to +60°C (23 to 140°F)
Operating humidity: 30 to 90 %RH (non-condensing)
Mounting: Surface or DIN rail
Weight: 430 g (0.95 lb)

PERFORMANCE in percentage of span

Accuracy: ± 0.1 % (input ≥ 3 mV)
Display accuracy: $\pm (0.1$ % of FS + 1 digit) (input ≥ 3 mV)
Temp. coefficient: ± 0.015 %/°C (± 0.008 %/°F) (input ≥ 3 mV)
Line voltage effect: ± 0.1 % over voltage range
Insulation resistance: ≥ 100 M Ω with 500 V DC
Dielectric strength: 2000 V AC @1 minute for AC power
 1000 V AC @1 minute for DC power
 (input or output to power)
 1000 V AC @1 minute (input to output)
 2000 V AC @1 minute
 (input or output or power to ground)

EXTERNAL VIEW

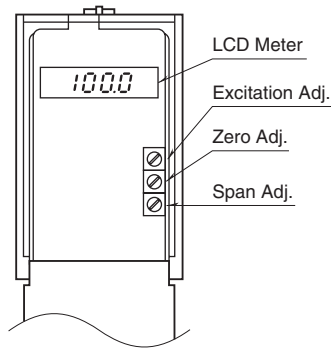

EXTERNAL DIMENSIONS & TERMINAL ASSIGNMENTS unit: mm [inch]

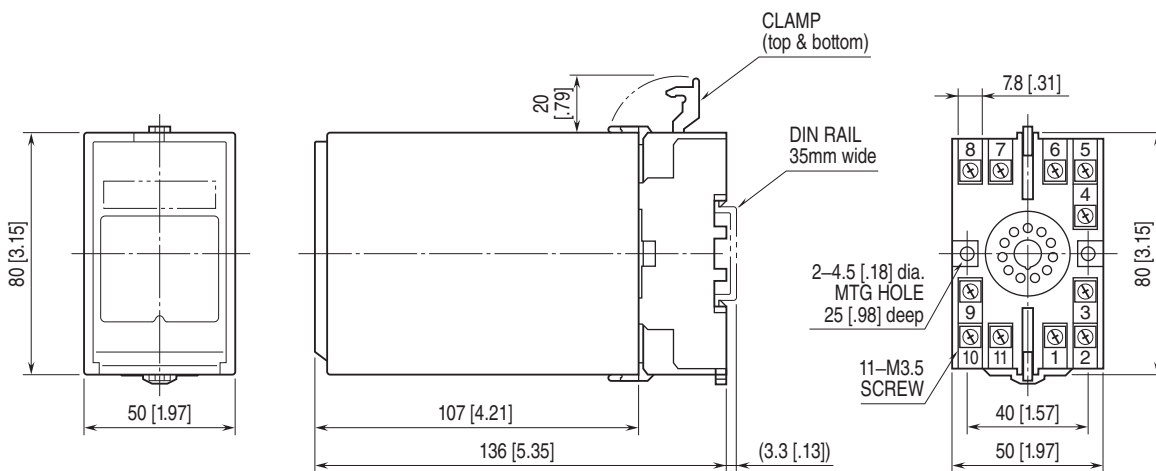

• When mounting, no extra space is needed between units.

SCHEMATIC CIRCUITRY & CONNECTION DIAGRAM

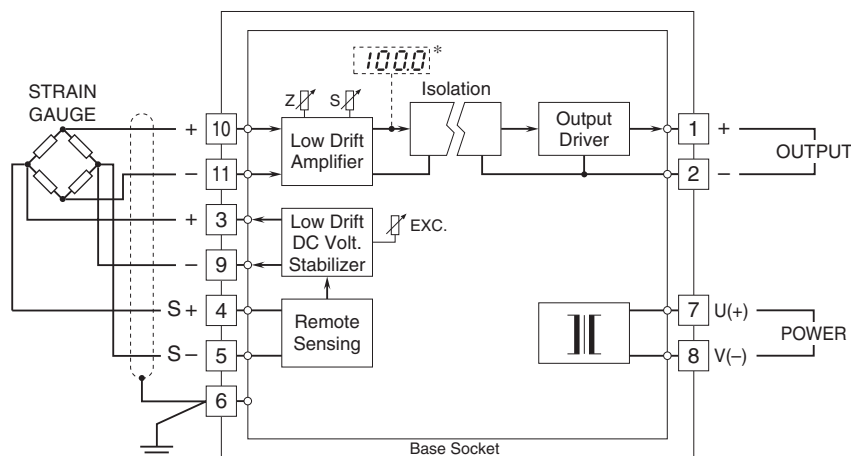

Close across the terminal 3 - 4 and 5 - 9 when the remote sensing is not used.
* Option /E



Specifications are subject to change without notice.