

Power Transducer Series L-UNIT

PT/CT TRANSDUCER

(Average sensing, RMS calibrated)

Functions & Features

- VT and CT transducers combined in one housing
- Minimum ripple
- Isolation up to 2000 V AC
- High-density mounting

Typical Applications

- Centralized monitoring and control of power line and power supply voltages measured at switch boards
- Centralized monitoring and control of current in motors
- Monitoring abnormal voltage drops at switch boards and abnormal current in motors for detecting overload

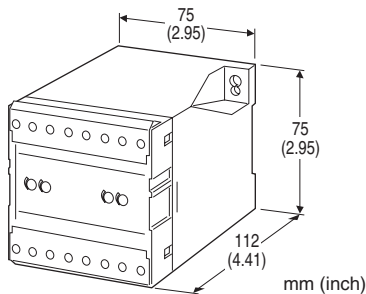

MODEL: LPCA-[1][2][3]-[4][5]

ORDERING INFORMATION

- Code number: LPCA-[1][2][3]-[4][5]
- Specify a code from below for each of [1] through [5].
(e.g. LPCA-55A-C/Q)
- Special output range (For codes Z & 0)
- Specify the specification for option code /Q
(e.g. /C01/S01)

[1] VT INPUT

- Voltage
- 5: 0 - 150 V AC
 - 6: 0 - 300 V AC

[2] CT INPUT

- Current
- 1: 0 - 1 A AC
 - 5: 0 - 5 A AC

[3] OUTPUT

- Current
- A: 4 - 20 mA DC (Load resistance 500 Ω max.)

- D: 0 - 20 mA DC (Load resistance 500 Ω max.)
 - E: 0 - 16 mA DC (Load resistance 625 Ω max.)
 - F: 0 - 10 mA DC (Load resistance 1000 Ω max.)
 - G: 0 - 1 mA DC (Load resistance 10 kΩ max.)
 - J: 0 - 5 mA DC (Load resistance 2000 Ω max.)
 - Z: Specify current (See OUTPUT SPECIFICATIONS)
- Voltage
- 1: 0 - 10 mV DC (Load resistance 10 kΩ min.)
 - 2: 0 - 100 mV DC (Load resistance 100 kΩ min.)
 - 3: 0 - 1 V DC (Load resistance 1000 Ω min.)
 - 4: 0 - 10 V DC (Load resistance 10 kΩ min.)
 - 5: 0 - 5 V DC (Load resistance 5000 Ω min.)
 - 6: 1 - 5 V DC (Load resistance 5000 Ω min.)
 - 0: Specify voltage (See OUTPUT SPECIFICATIONS)

[4] AUXILIARY POWER SUPPLY

- AC Power
- B: 100 V AC
 - C: 110 V AC
 - D: 115 V AC
 - F: 120 V AC
 - G: 200 V AC
 - H: 220 V AC
 - J: 240 V AC
- DC Power
- R: 24 V DC
 - V: 48 V DC

[5] OPTIONS

- blank: none
- /Q: With options (specify the specification)

SPECIFICATIONS OF OPTION: Q (multiple selections)

- COATING (For the detail, refer to our web site.)
- /C01: Silicone coating
 - /C02: Polyurethane coating
 - /C03: Rubber coating
- TERMINAL SCREW MATERIAL
- /S01: Stainless steel

GENERAL SPECIFICATIONS

- Construction:** Stand-alone; terminal access at the front
- Connection:** M3.5 screw terminals (torque 0.8 N·m)
- Screw terminal:** Nickel-plated steel (standard) or stainless steel
- Housing material:** Flame-resistant resin (black)
- Isolation:** Input to output to auxiliary power, between channels
- Input waveform:** Sine wave
- Overrange output:** 0 to 120 % at 1 - 5 V

Zero adjustment: -5 to +5 % (front)
 Span adjustment: 95 to 105 % (front)

Weight: 400 g (0.88 lb)

INPUT SPECIFICATIONS

Frequency: 50 or 60 Hz

• VT Input

Input burden: 0.3 VA

Overload capacity: 150 % of rating for 10 sec.,
 120 % continuous

Operational range: 0 - 120 % of rating

• CT Input

Input burden: 0.5 VA

Overload capacity: 1000 % of rating for 3 sec., 200 % for 10
 sec., 120 % continuous

Operational range: 0 - 120 % of rating

PERFORMANCE in percentage of span

Accuracy: $\pm 0.5\%$ (at $23^{\circ}\text{C} \pm 10^{\circ}\text{C}$ or $73.4^{\circ}\text{F} \pm 18^{\circ}\text{F}$,
 45 - 65 Hz)

Response time: ≤ 1 sec. (0 - 100 % $\pm 1\%$)

Ripple: 0.5 %p-p max.

Line voltage effect: $\pm 0.1\%$ over voltage range

Insulation resistance: $\geq 100\text{ M}\Omega$ with 500 V DC

Dielectric strength: 2000 V AC @ 1 minute
 (input to output to auxiliary power to ground, between
 channels)

Impulse withstand voltage: 1.2 / 50 $\mu\text{sec.}$, $\pm 5\text{ kV}$
 (input to output or ground)

OUTPUT SPECIFICATIONS

■ DC Current: 0 - 20 mA DC

Minimum span: 1 mA

Offset: Max. 1.5 times span

Load resistance: Output drive 10 V max.

■ DC Voltage: 0 - 12 V DC

Minimum span: 5 mV

Offset: Max. 1.5 times span

Load resistance: Output drive 1 mA max.; at $\geq 0.5\text{ V}$

■ OPERATION DIAGRAM (example)

•VT Input

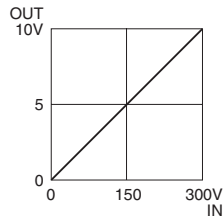
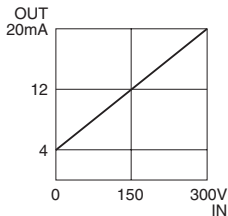

•CT Input

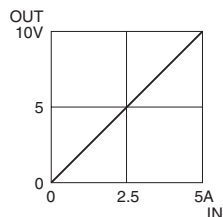
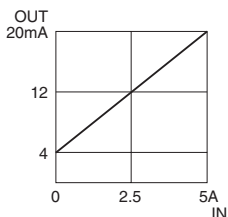

INSTALLATION

Auxiliary power supply

•AC: Operational voltage range: rating -15/+10 %, 50/60 Hz, approx. 3 VA

•DC: Operational voltage range: rating $\pm 10\%$ ripple 10 %p-p max., approx. 3 W (125 mA at 24 V)

Operating temperature: -10 to +55°C (14 to 131°F)

Operating humidity: 30 to 85 %RH (non-condensing)

Mounting: Surface or DIN rail

CONNECTION DIAGRAM

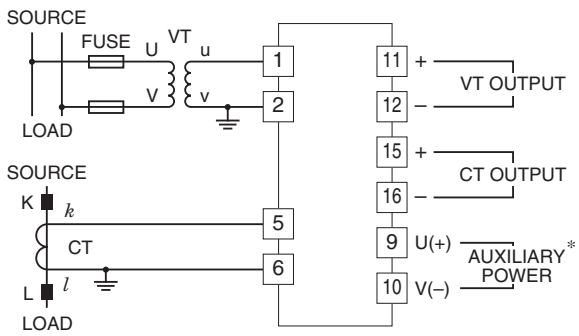

*The transducer can be powered from the input voltage when the voltage is sufficiently stable and meets within the range of auxiliary power supply of the unit specified in the data sheet/instruction manual.

EXTERNAL DIMENSIONS & TERMINAL ASSIGNMENTS unit: mm [inch]

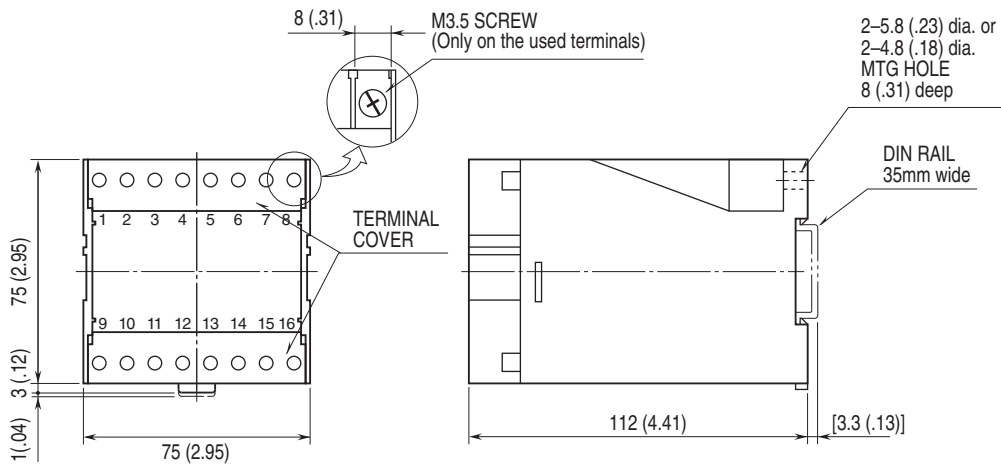

•When mounting, no extra space is needed between units.

MOUNTING REQUIREMENTS unit: mm [inch]

■ M5 SCREWS

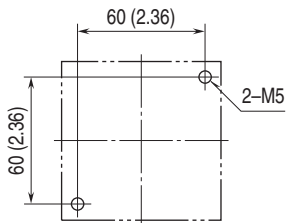

■ M4 SCREWS

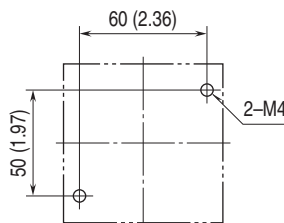

Specifications are subject to change without notice.