

Lightning Surge Protectors for Electronics Equipment M-RESTER

LIGHTNING SURGE PROTECTOR FOR POWER SUPPLY USE

(5 A; high discharge current capacity)

Functions & Features

- Designed specifically for AC power supplies up to 5 A
- Discharge current capacity 10000 A
- Absorbing surges only without affecting instrumentation signal
- No power supply interruption even when the surge absorber is broken
- Relay contact turns ON with surge absorber failure
- Surge absorber element replaceable without power interruption

Typical Applications

- High discharge current capacity is beneficial for use in area with frequent lightnings

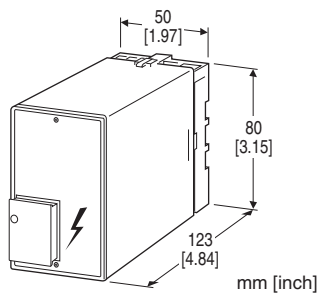

MODEL: MAX-[1]

ORDERING INFORMATION

- Code number: MAX-[1]
- Specify a code from below for [1].
(e.g. MAX-100)

[1] OPERATIONAL VOLTAGE

100: 100 V / 110 V / 120 V AC
200: 200 V / 220 V / 240 V AC

RELATED PRODUCTS

- Lightning surge protector for standard signal line use (model: MMD-24)
- Surge absorber element (model: MEL)

GENERAL SPECIFICATIONS

Construction: Plug-in

Connection: M3.5 screw terminals (torque 0.8 N·m)

Screw terminal: Chromated steel

Housing material: Flame-resistant resin (black)

Alarm indicator: Surge absorber failure indicator turns white when the fuse is blown.

Alarm contact: Turns ON with surge absorber failure (when the fuse is blown or when the surge absorber element is extracted.)

• Rating:

125 V AC @1 A (cos ϕ = 1)

30 V DC @1 A (resistive load)

• **Maximum switching voltage:** 220 V AC, 250 V DC

• **Maximum switching power:** 125 VA, 100 W

• **Minimum load:** 5 V DC @1 mA

INSTALLATION

Operating temperature: -10 to +55°C (14 to 131°F)

Operating humidity: 30 to 90 %RH (non-condensing)

Mounting: Surface or DIN rail

Weight: 470 g (1.04 lb)

PERFORMANCE

Discharge voltage (peak-to-peak)

Line to line:

≥ 190 V (MAX-100)

≥ 410 V (MAX-200)

Line to ground: ≥ 640 V

Maximum surge voltage

Line to line:

≤ 350 V (MAX-100)

≤ 700 V (MAX-200)

Line to ground: ≤ 800 V

(Withstand voltage of protected equipment between circuit and metal housing must be 1000 V AC or more.)

Note: This is the maximum voltage that could pass through M-RESTER. Protected equipment must be able to withstand this voltage for very short time period.

Response time: ≤ 0.01 μ sec.

Leakage current

Line to line:

≤ 1 mA at 150 V DC (MAX-100)

≤ 1 mA at 300 V DC (MAX-200)

Line to ground: ≤ 1 mA at 300 V DC

Discharge current capacity: 10000 A (8/ 20 μ sec.)

Maximum load current: 5 A

Internal series resistance: ≤ 0.5 Ω including return

EXTERNAL VIEW

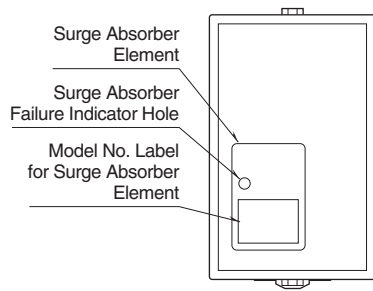

GROUNDING

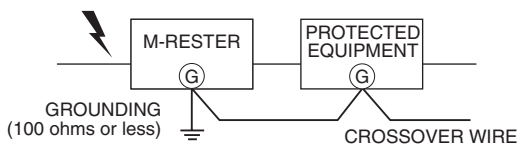

A crossover wire between M-RESTER ground and ground or metallic housing of equipment is required for protection.
If the protected equipment has no ground terminal, ground the M-RESTER only.

EXTERNAL DIMENSIONS & TERMINAL ASSIGNMENTS unit: mm [inch]

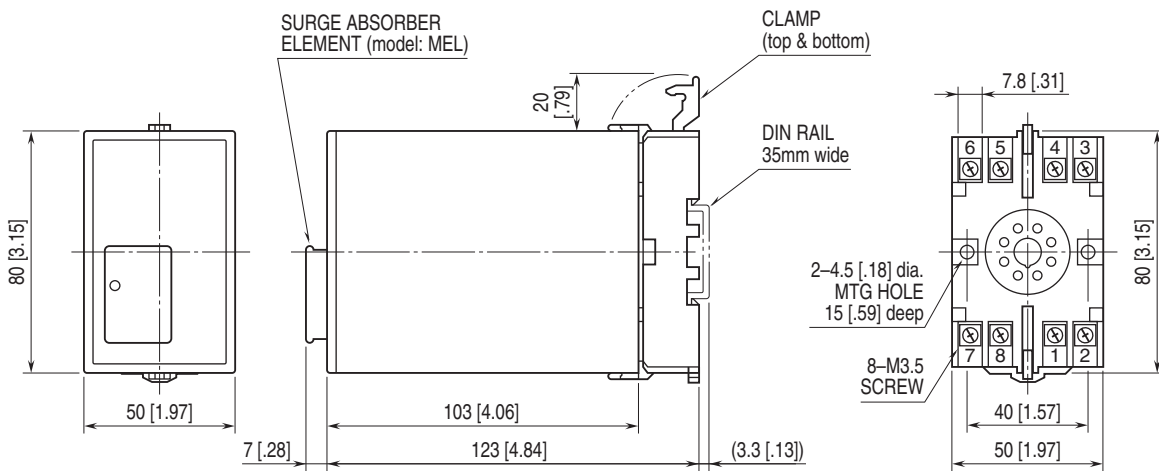

•When mounting, no extra space is needed between units.

SCHEMATIC CIRCUITRY & CONNECTION DIAGRAM

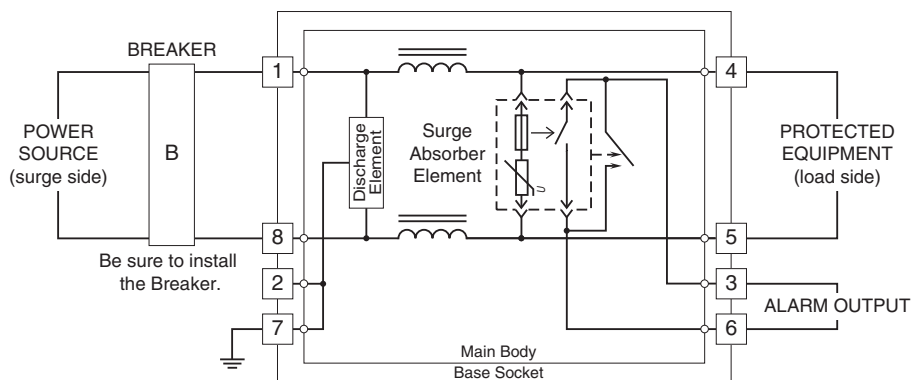

Specifications are subject to change without notice.