

Plug-in Signal Conditioners M-UNIT

H: 220 V AC

J: 240 V AC

EXCITATION SUPPLY

Functions & Features

- Highly regulated DC power supply
- Output voltage fully adjustable over its entire span
- MDC-3 features separate regulated and unregulated outputs
- Powering up to three standard 4 - 20 mA loops simultaneously
- Shortcircuit protection
- Highdensity mounting

Typical Applications

- Strain gauge bridge excitation
- Voltage reference and general-purpose power supply needs
- Various 2-wire transmitters

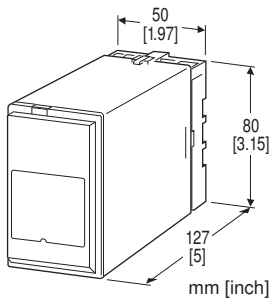

MODEL: MDC-[1]-[2][3]

ORDERING INFORMATION

- Code number: MDC-[1]-[2][3]
- Specify a code from below for each of [1] through [3].
(e.g. MDC-1-B/Q)
- Specify the specification for option code /Q
(e.g. /C01/S01/SET)

[1] SUPPLY OUTPUT

- 1: 3 - 15 V DC adjustable
- 2: 5 - 30 V DC adjustable
- 3: 24 V DC regulated and 40 V DC unregulated

[2] POWER INPUT

- AC Power
- B: 100 V AC
 - C: 110 V AC
 - D: 115 V AC
 - F: 120 V AC
 - G: 200 V AC

[3] OPTIONS

blank: none

/Q: With options (specify the specification)

SPECIFICATIONS OF OPTION: Q (multiple selections)

COATING (For the detail, refer to our web site.)

/C01: Silicone coating

/C02: Polyurethane coating

/C03: Rubber coating

TERMINAL SCREW MATERIAL

/S01: Stainless steel

EX-FACTORY SETTING

/SET: Preset according to the Ordering Information Sheet
(No. ESU-9222)

GENERAL SPECIFICATIONS

Construction: Plug-in

Connection: M3.5 screw terminals

Screw terminal: Chromated steel (standard) or stainless steel

Housing material: Flame-resistant resin (black)

Isolation: Output to power

SUPPLY OUTPUT

- Output voltage:
 - MDC-1: 3 - 15 V DC (adjustable on front)
(If not specified the default value is used 12V DC)
 - MDC-2: 5 - 30 V DC (adjustable on front)
(If not specified the default value is used 24V DC)
 - MDC-3: 24 V DC regulated and 40 V DC unregulated

Load current:

- MDC-1, -2: ≤ 50 mA
- MDC-3: ≤ 65 mA (for the total of both outputs)

• Shortcircuit Protection

MDC-1, -2

Current limited: 65 mA max.

Protected time duration: No limit

MDC-3

Current limited: 85 mA max. at 24 V

Protected time duration: No limit

INSTALLATION

Power input

- AC: Rating ± 10 %, 50/60 ± 2 Hz

Approx. 2 VA for MDC-1

Approx. 3.5 VA for MDC-2, -3

Operating temperature: -5 to +60°C (23 to 140°F)

Operating humidity: 30 to 90 %RH (non-condensing)

Mounting: Surface or DIN rail

Weight: 290 g (0.64 lb)

PERFORMANCE in percentage of span

Temp. coefficient:

MDC-1, -2: $\pm 0.03\%/^{\circ}\text{C}$ ($\pm 0.02\%/^{\circ}\text{F}$)

MDC-3: $\pm 0.03\%/^{\circ}\text{C}$ ($\pm 0.02\%/^{\circ}\text{F}$) at 24 V

Ripple:

MDC-1, -2: 15 mVp-p max. at 50 mA output

MDC-3: 15 mVp-p max. at 24 V/65 mA output

Load effect:

MDC-1, -2: -0.1 % or -5 mV, whichever is greater as absolute value with 0 - 50 mA variation

MDC-3: -0.1 % max. with 0 - 65 mA variation at 24 V

Line voltage effect:

MDC-1, -2: $\pm 0.5\%$ over voltage range

MDC-3: $\pm 0.5\%$ over voltage range at 24 V

Insulation resistance: $\geq 100\text{ M}\Omega$ with 500 V DC

Dielectric strength: 2000 V AC @ 1 minute (output to power to ground)

EXTERNAL DIMENSIONS & TERMINAL ASSIGNMENTS unit: mm [inch]

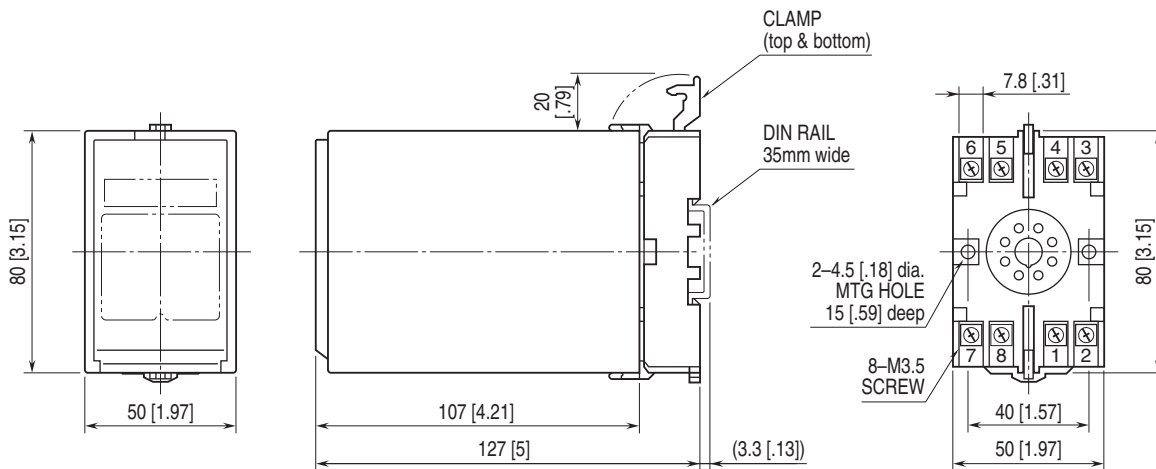

• When mounting, no extra space is needed between units.

SCHEMATIC CIRCUITRY & CONNECTION DIAGRAM

■ MDC-1 & -2

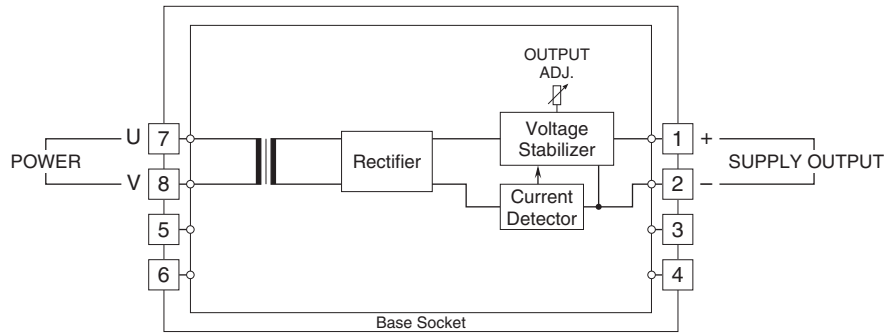

■ MDC-3

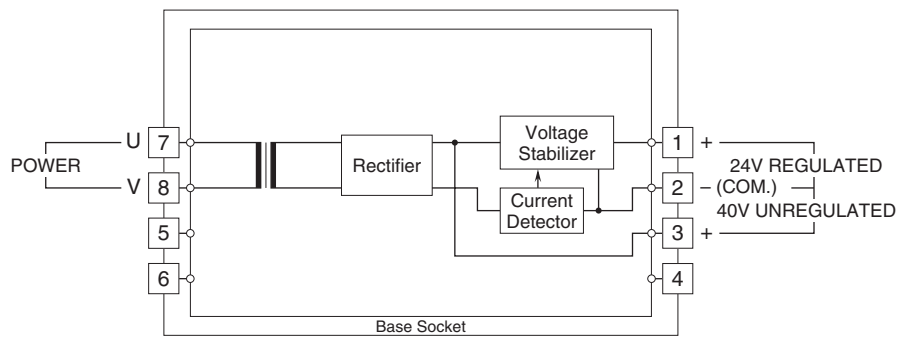

Specifications are subject to change without notice.