

Final Control Elements

VALVE POSITIONER

(potentiometer feedback; built-in SSR)

Functions & Features

- Controlling an electric actuator powered with 100 V AC
- Feedback potentiometer 100 Ω - 10 kΩ
- Built-in SSR directly drives an AC motor
- Timer for motor's overheat protection
- Re-transmitted output

Typical Applications

- Single phase AC motor
- Loop powered isolator can be used for isolating between setpoint input signal and transmitter output signal

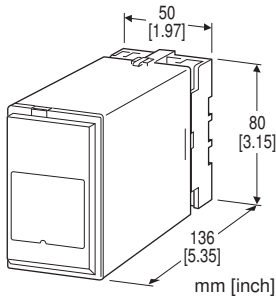

MODEL: MEX-B-[1][2]

ORDERING INFORMATION

- Code number: MEX-B-[1][2]
- Specify a code from below for each of [1] and [2]. (e.g. MEX-B-B/Q)
- Specify the specification for option code /Q (e.g. /C01/BD/S01)

[1] POWER INPUT

- AC Power
- B:** 100 V AC
 - C:** 110 V AC
 - D:** 115 V AC
 - F:** 120 V AC
 - G:** 200 V AC
 - H:** 220 V AC
 - J:** 240 V AC

[2] OPTIONS

- blank:** none
/Q: With options (specify the specification)

SPECIFICATIONS OF OPTION: Q (multiple selections)

COATING (For the detail, refer to our web site.)

- /C01:** Silicone coating
- /C02:** Polyurethane coating
- /C03:** Rubber coating

Optional Process

- /BD:** Bonding
- TERMINAL SCREW MATERIAL
- /S01:** Stainless steel

GENERAL SPECIFICATIONS

Construction: Plug-in

Connection: M3.5 screw terminals

Screw terminal: Chromated steel (standard) or stainless steel

Housing material: Flame-resistant resin (black)

Deadband adjustment: 2 - 20 % (front)

Timer adjustment: 1 - 30 sec. (front)

Isolation: Input or xmtr output to output to power

Zero adjustment: 0 - 25 % (front)

Span adjustment: 75 - 100 % (front)

INPUT SPECIFICATIONS

- **Setpoint Signal:** 4 - 20 mA DC; input resistor incorporated
Input resistance: 100 Ω
- **Feedback Potentiometer:** 100 Ω - 10 kΩ
- Minimum span:** 50 % of total resistance
- Excitation:** 0.5 V DC

OUTPUT SPECIFICATIONS

- **Re-Transmitted Output:** 4 - 20 mA DC
Load resistance: 750 Ω max.
 - **Control Output:** SSR (zero-crossing);
60 - 280 V AC @ 0.1 - 1 A
- Note 1: The incorporated SSR is not capable for driving 200 V AC motor.
- Note 2: When driving relays with this control output, relays may operate erratically due to the leakage current at OFF of SSR. To avoid the problem, install a resistor (R) in parallel with the relay coil.
- $$R < [\text{Release Voltage}] \div [([\text{Leakage Current at OFF}] - [\text{Release Current}])]$$
- Leakage current at OFF:** Approx. 10 mA @ 240 V
- **Output Operation** (terminal No. in parentheses)

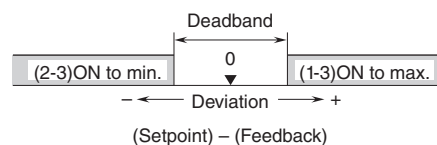

INSTALLATION

Power input

•AC: Operational voltage range: rating $\pm 10\%$,
50/60 ± 2 Hz, approx. 3 VA

Operating temperature: -5 to +60°C (23 to 140°F)

Operating humidity: 30 to 90 %RH (non-condensing)

Mounting: Surface or DIN rail

Weight: 300 g (0.66 lb)

PERFORMANCE in percentage of span

Position conversion accuracy: $\pm 0.5\%$

Insulation resistance: $\geq 100\text{ M}\Omega$ with 500 V DC

Dielectric strength: 1000 V AC @ 1 minute

(input or xmtr output to output to power)

2000 V AC @ 1 minute (input or xmtr output or output or
power to ground)

EXTERNAL VIEW

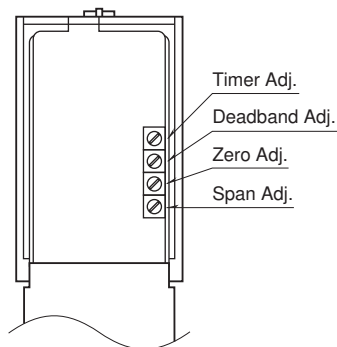

EXTERNAL DIMENSIONS & TERMINAL ASSIGNMENTS unit: mm [inch]

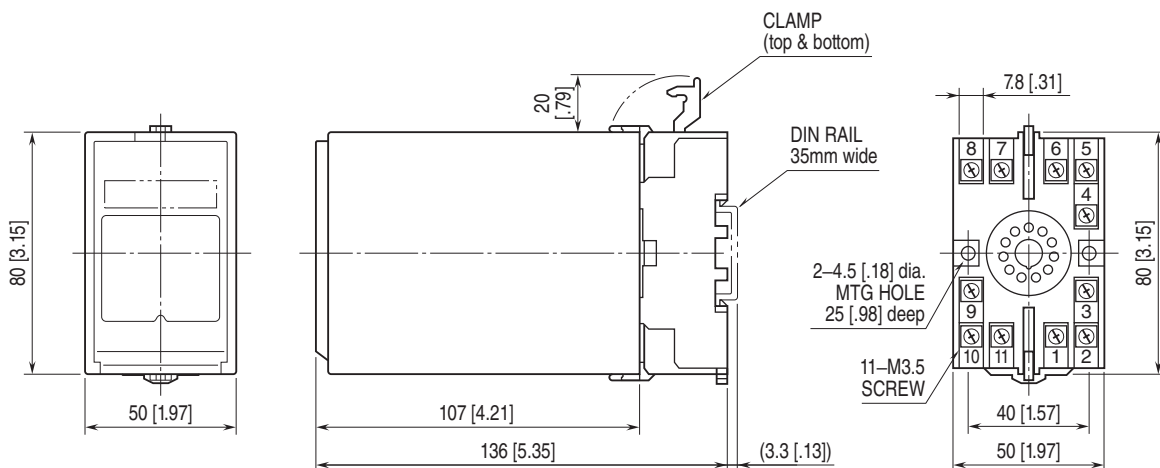

• When mounting, no extra space is needed between units.

SCHEMATIC CIRCUITRY & CONNECTION DIAGRAM

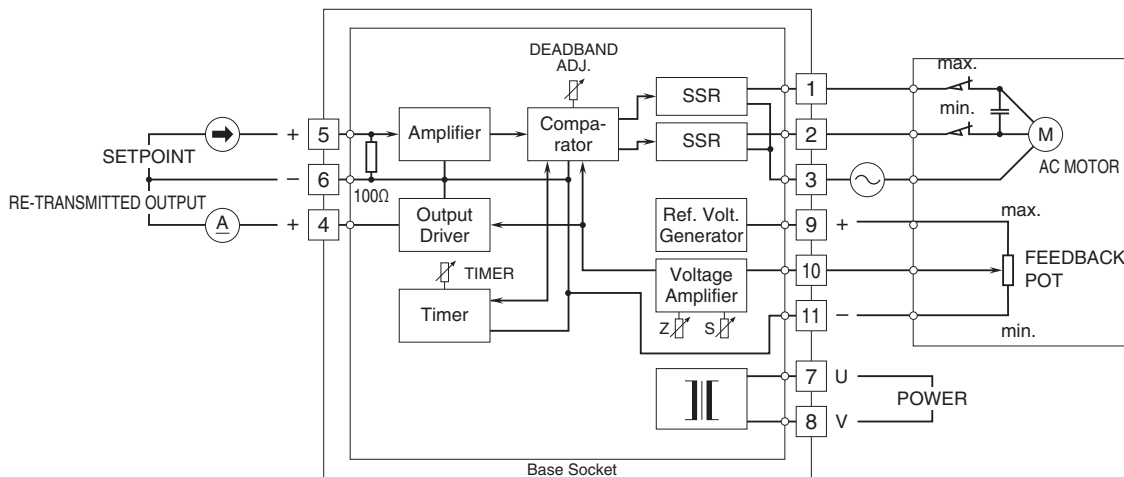

EXPLANATIONS OF TERMS

• **SSR (Solid State Relay)**

Composed only of semiconductor parts, SSR is free from arc discharge or chattering which is typical with electromagnetic relays. It features excellent characteristics against vibration, physical impact or other environmental conditions.

• **Zero-Cross Function**

SSR with zero-cross function turns on when AC power voltage is near zero, creating delay of switching when input is provided in the middle of an wave cycle, thus limiting transient switching noise voltage and rush current.

• **Bonding**

An silicone adhesive reinforces the part, which is sensitive to vibration, on PWB. The improvement of vibration performance is not assured.



Specifications are subject to change without notice.