

Plug-in Signal Conditioners M-UNIT

DIGITAL MULTIPLIER

Functions & Features

- Accepting two DC inputs and providing a standard process signal proportional to the multiplication of the two signals
- Isolation up to 2000 V AC
- LCD meter
- High-density mounting

Typical Applications

- DC wattmeter (multiplying voltage and current inputs)
- Remote gain control (potentiometer signals pre-converted into 1 - 5 V, provided to the MLS inputs)

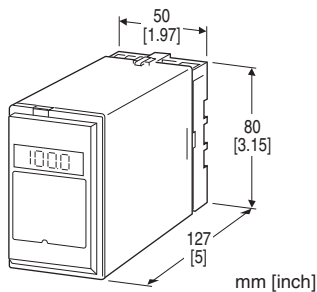

MODEL: MLS-[1][2][3]-[4][5]

ORDERING INFORMATION

- Code number: MLS-[1][2][3]-[4][5]
- Specify a code from below for each of [1] through [5].
(e.g. MLS-6AA-B/E/Q)
- Special input and output ranges (For codes Z & 0)
- Parameters (e.g. $K_1 = 0.50$, $K_2 = 0.90$)
- Specify the specification for option code /Q
(e.g. /C01/S01)

[1] INPUT 1

Current

- A: 4 - 20 mA DC (Input resistance 250 Ω)
- A1: 4 - 20 mA DC (Input resistance 50 Ω)
- B: 2 - 10 mA DC (Input resistance 500 Ω)
- C: 1 - 5 mA DC (Input resistance 1000 Ω)
- D: 0 - 20 mA DC (Input resistance 50 Ω)
- E: 0 - 16 mA DC (Input resistance 62.5 Ω)
- F: 0 - 10 mA DC (Input resistance 100 Ω)
- G: 0 - 1 mA DC (Input resistance 1000 Ω)
- H: 10 - 50 mA DC (Input resistance 100 Ω)
- K: 0 - 100 μ A DC (Input resistance 1000 Ω)
- GW: -1 - +1 mA DC (Input resistance 1000 Ω)
- FW: -10 - +10 mA DC (Input resistance 100 Ω)

Z: Specify current (See INPUT SPECIFICATIONS)
Voltage

- 1: 0 - 10 mV DC (Input resistance 10 k Ω min.)
- 2: 0 - 100 mV DC (Input resistance 100 k Ω min.)
- 3: 0 - 1 V DC (Input resistance 1 M Ω min.)
- 4: 0 - 10 V DC (Input resistance 1 M Ω min.)
- 5: 0 - 5 V DC (Input resistance 1 M Ω min.)
- 6: 1 - 5 V DC (Input resistance 1 M Ω min.)
- 4W: -10 - +10 V DC (Input resistance 1 M Ω min.)
- 5W: -5 - +5 V DC (Input resistance 1 M Ω min.)
- 0: Specify voltage (See INPUT SPECIFICATIONS)

[2] INPUT 2

Same range availability as Input 1

[3] OUTPUT

Current

- A: 4 - 20 mA DC (Load resistance 750 Ω max.)
- B: 2 - 10 mA DC (Load resistance 1500 Ω max.)
- C: 1 - 5 mA DC (Load resistance 3000 Ω max.)
- D: 0 - 20 mA DC (Load resistance 750 Ω max.)
- E: 0 - 16 mA DC (Load resistance 900 Ω max.)
- F: 0 - 10 mA DC (Load resistance 1500 Ω max.)
- G: 0 - 1 mA DC (Load resistance 15 k Ω max.)
- Z: Specify current (See OUTPUT SPECIFICATIONS)

Voltage

- 1: 0 - 10 mV DC (Load resistance 10 k Ω min.)
- 2: 0 - 100 mV DC (Load resistance 100 k Ω min.)
- 3: 0 - 1 V DC (Load resistance 100 Ω min.)
- 4: 0 - 10 V DC (Load resistance 1000 Ω min.)
- 5: 0 - 5 V DC (Load resistance 500 Ω min.)
- 6: 1 - 5 V DC (Load resistance 500 Ω min.)
- 4W: -10 - +10 V DC (Load resistance 2000 Ω min.)
- 5W: -5 - +5 V DC (Load resistance 1000 Ω min.)
- 0: Specify voltage (See OUTPUT SPECIFICATIONS)

[4] POWER INPUT

AC Power

- B: 100 V AC
- C: 110 V AC
- D: 115 V AC
- F: 120 V AC
- G: 200 V AC
- H: 220 V AC
- J: 240 V AC
- DC Power
- S: 12 V DC
- R: 24 V DC
- V: 48 V DC

[5] OPTIONS (multiple selections)

Multiplication Indicator

blank: Without

/E: With (0.0 - 100.0 % display)

Other Options

blank: none

/Q: Option other than the above (specify the specification)

SPECIFICATIONS OF OPTION: Q (multiple selections)

COATING (For the detail, refer to our web site.)

/C01: Silicone coating

/C02: Polyurethane coating

/C03: Rubber coating

TERMINAL SCREW MATERIAL

/S01: Stainless steel

GENERAL SPECIFICATIONS

Construction: Plug-in

Connection: M3.5 screw terminals

Screw terminal: Chromated steel (standard) or stainless steel

Housing material: Flame-resistant resin (black)

Isolation: Input 1 or input 2 to output to power
(Negative sides of the input 1 and 2 must be of the same potential.)

Overrange output: 0 to 115 % at 1 - 5 V

Zero adjustment: -5 to +5 % (front)

Span adjustment: 95 to 105 % (front)

Equation: Output = $K_1 \times \text{Input 1} \times K_2 \times \text{Input 2}$

$K_1, K_2:$ 0.10 - 1.15 (parameters)

where $K_1 \times K_2 \geq 0.2$

Input 1, Input 2: 0 - 115 %; forcibly limited to 0 % or 115 % with overrange.

Output: 0 - 115 % with $K_1 \times K_2 \geq 1$;

forcibly limited to 0 % or 115 % with overrange.

0 - $[115 \times K_1 \times K_2]$ % with $K_1 \times K_2 < 1$;

forcibly limited to 0 % or $[115 \times K_1 \times K_2]$ % with overrange.

K_1, K_2 are ex-factory specified.

[example]

K_1	K_2	INP1	INP2	OUT
1.00	1.15	115 %	100 %	115 %
1.00	1.15	100 %	50 %	57.5 %
1.00	1.15	100 %	-5 %	0 %

■ **DISPLAY (Multiplied values indicator)**

LCD digital display: 0.0 - 100.0 % (min. digit 0.1 %)

(No scaling)

INPUT SPECIFICATIONS

■ **DC Current:**

Shunt resistor attached to the input terminals (0.5 W)

Specify input resistance value for code Z.

■ **DC Voltage:** -300 - +300 V DC

Minimum span: 10 mV

Offset: Max. 1.5 times span

Input resistance

Span 10 - 100 mV : $\geq 10 \text{ k}\Omega$

Span 0.1 - 1 V : $\geq 100 \text{ k}\Omega$

Span $\geq 1 \text{ V}$: $\geq 1 \text{ M}\Omega$

OUTPUT SPECIFICATIONS

■ **DC Current:** 0 - 20 mA DC

Minimum span: 1 mA

Offset: Max. 1.5 times span

Load resistance: Output drive 15 V max.

■ **DC Voltage:** -10 - +12 V DC

Minimum span: 5 mV

Offset: Max. 1.5 times span

Load resistance: Output drive 10 mA max.; 5 mA for negative voltage output; at $\geq 0.5 \text{ V}$

INSTALLATION

Power input

• **AC:** Operational voltage range: rating $\pm 10 \%$,
50/60 ± 2 Hz, approx. 3 VA

• **DC:** Operational voltage range: rating $\pm 10 \%$,
ripple 10 %p-p max., approx. 2 W (80 mA at 24 V)

Operating temperature: -5 to +60°C (23 to 140°F)

Operating humidity: 30 to 90 %RH (non-condensing)

Mounting: Surface or DIN rail

Weight: 350 g (0.77 lb)

PERFORMANCE in percentage of span

Accuracy: $\pm 0.2 \%$

Display accuracy: $\pm (0.2 \%$ of FS + 1 digit)

Temp. coefficient: $\pm 0.02 \%$ /°C ($\pm 0.01 \%$ /°F)

Response time: $\leq 0.5 \text{ sec.}$ (0 - 90 %)

Line voltage effect: $\pm 0.1 \%$ over voltage range

Insulation resistance: $\geq 100 \text{ M}\Omega$ with 500 V DC

Dielectric strength: 2000 V AC @1 minute (input 1 or input 2 to output to power to ground)

EXTERNAL DIMENSIONS unit: mm [inch]

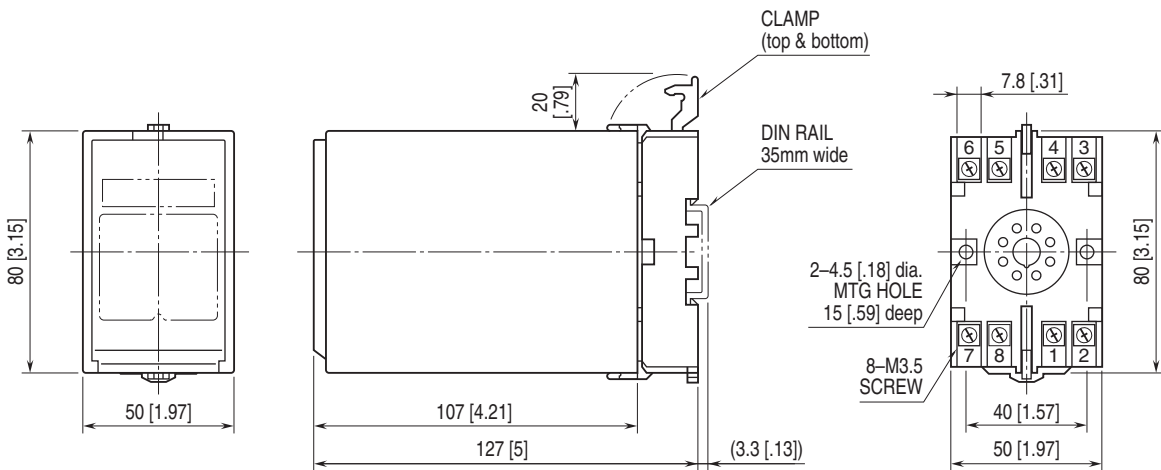

• When mounting, no extra space is needed between units.

TERMINAL ASSIGNMENTS unit: mm [inch]

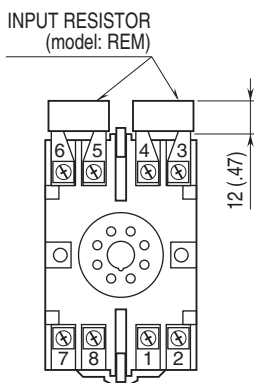

Input shunt resistor attached for current input.

SCHEMATIC CIRCUITRY & CONNECTION DIAGRAM

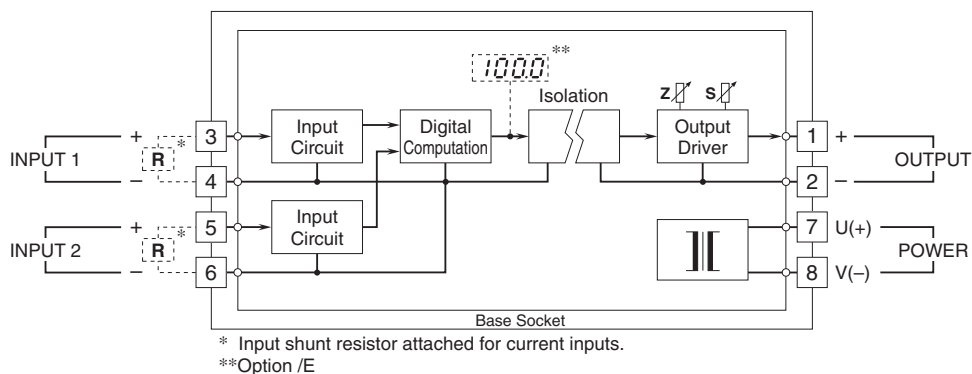

Specifications are subject to change without notice.