

Limit Alarms *M-PAC*

RTD INPUT LIMIT ALARM

MODEL MP1400-1423

MODEL & SUFFIX CODE SELECTION

MP14□□-□□/□

- MODEL** _____
- INPUT TYPE** _____
- 4** : RTD
- RELAY CONTACT OUTPUT** _____
- 0** : Single (Hi) trip, non-latching
- 1** : Single (Hi) trip, latching
- 2** : Dual (Hi/Lo) trip, non-latching
- SETPOINT CONTROL** _____
- 0** : Front-accessed three-turn screwdriver adjust.
- 2** : Remote dial connections (total resistance 1k – 100k Ω)
- 3** : DC programmable (0 – 1V)
- INPUT RTD (2- or 3-wire)** _____
- 4** : Pt 100 Ω (DIN, IEC751)
- 0** : Specify
- POWER INPUT** _____
- F** : 120V AC
- J** : 240V AC
- R** : 24V DC
- S** : 12V DC
- OPTIONS** _____
- H** : Latching operation for dual trip (142X only);
Reset at power off (5 seconds min.)
- R** : Reversed relay sense
- T** : Transmitter output (0 – 1V DC)
- V** : Relay drive voltage output
- X** : Lo-trip sense for single trip; Lo/Lo for dual trip
- Y** : Hi/Hi-trip sense for dual trip (142X only)

ORDERING INFORMATION

Specify code number and variables.

- **Code number** (e.g. MP1400-4-F/T/V)
- **Temperature range** (e.g. 0 – 100 $^{\circ}$ C)

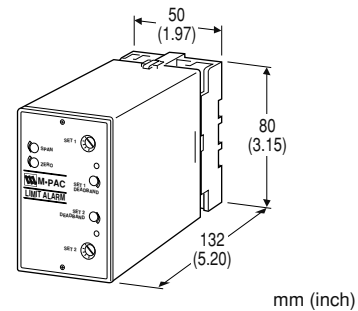

Functions & Features

- Accepting 2- or 3-wire RTD inputs and providing relay contact closure(s) at a preset input level
- Upscale burnout protection as standard
- Downscale or no burnout optional
- Single, latching or dual setpoint
- Failsafe operation available
- Deadband adjustable from 1 to 100%
- Indicator LED provided

Typical Applications

- Annunciator
- Various alarm applications

GENERAL SPECIFICATIONS

Construction: plug-in

Connection: M3.5 screw terminals on base socket

Housing material: flame-resistant resin (black)

Isolation: input to output to power
(non-isolated between I/O with Option V)

Zero/span adjustments: $\pm 5\%$ (front)

Setpoint adjustments: front accessed three-turn screwdriver, remote dial potentiometer or DC input

Deadband adjustments: front accessed single-turn screwdriver; 1 – 100%

Front LEDs: red lights turn on at a tripped condition

Burnout protection: upscale standard; downscale or no burnout optional

Power ON timer: relays de-energized for approx. 2 seconds after power is turned on.

INPUT & OUTPUT

■**INPUT:** 2- or 3-wire Pt 100Ω
Maximum leadwire resistance: 200Ω per wire (3-wire)
Sensing current: 2mA
Temperature range

RTD	USABLE RANGE		MIN. SPAN	
	°C	°F	°C	°F
Pt 100/DIN	-200 to +600	-328 to +1112	50	90

■**REMOTE SETPOINT INPUT**

MP14X2: potentiometer; any value of 1k – 100kΩ;
excitation 4V

MP14X3: 0 – 1V DC

■**RELAY CONTACT OUTPUT**

- Single/Latching:** isolated DPDT relay; de-energized at trip
- Dual:** isolated SPDT relay; energized at trip

Rating: 120V AC @3A (cosφ=1)
30V DC @3A (resistive load)

Relay life

Electrical: 10⁵ cycles

Mechanical: 10⁷ cycles

For maximum relay life with inductive loads, external protection is recommended.

■**VOLTAGE OUTPUT (Option V):** 24V DC average;
Drives 1.2kΩ or greater coil impedance

■**TRANSMITTER OUTPUT (Option T):** 0 – 1V DC;
1mA max. (setpoint and process input)

INSTALLATION**Power input**

AC: rating ±10%, 50/60 ±2 Hz, approx. 2VA

DC: rating ±10% (ripple 10% p-p max.)
80mA at 24V, 160mA at 12V

Operating temperature: -5 to +60°C (23 to 140°F)

Storage temperature: -20 to +85°C (-5 to +185°F)

Operating humidity: 30 to 90% RH (non-condensing)

Mounting: surface (DIN rail available for 11-pin base)

Dimensions

11-pin base: W50×H80×D132 mm
(1.97"×3.15"×5.20")

See General Spec. Sheet Figure A.

20-pin base: W80×H101×D136 mm
(3.15"×3.98"×5.35")

See General Spec. Sheet Figure B.

Weight: 400 g (0.88 lbs)

PERFORMANCE in percentage of span

Repeatability: ±0.2%

Temp. coefficient: ±0.05%/°C (±0.027%/°F)

Response time: ≤0.5 sec. (0 – 100% at 90% setpoint)

Burnout response: 1 second

Common mode rejection

60 Hz: greater than 120 dB

DC: greater than 140 dB

Line voltage effect: ±0.1% over voltage range

Insulation resistance: ≥100MΩ with 500V DC

Dielectric strength: 1000V AC @1 minute
(input to output to power)

2000V AC @1 minute (output to ground)

BLOCK DIAGRAM

■ SINGLE / LATCHING OUTPUT

•11-pin Base

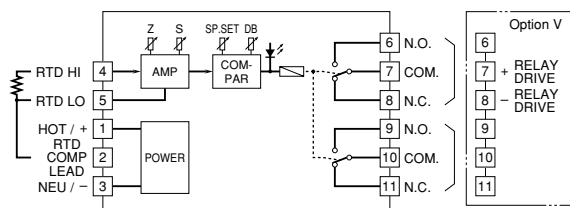

•20-pin Base

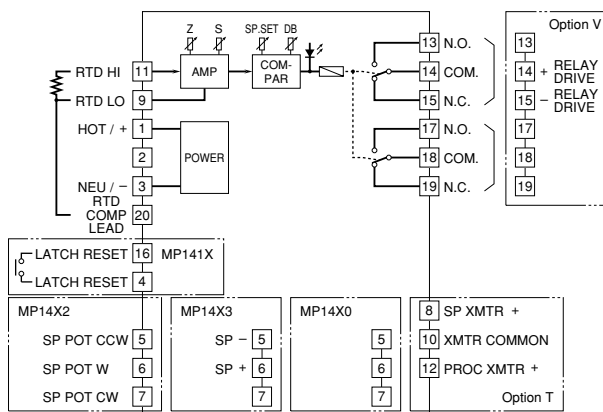

■ DUAL OUTPUT

•11-pin Base

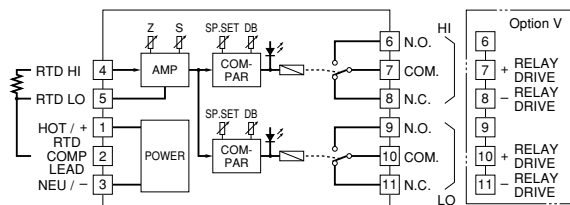

•20-pin Base

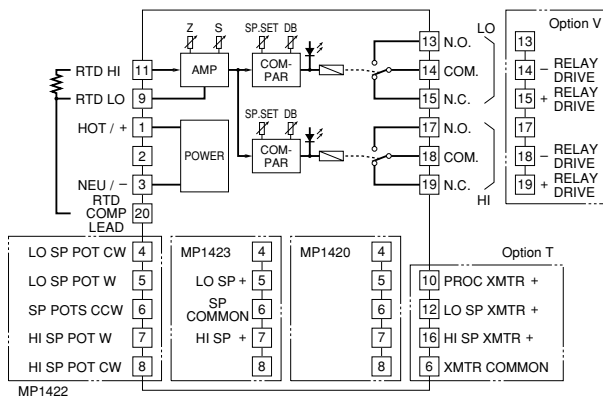

TERMINAL ASSIGNMENT

■SINGLE OUTPUT

PIN	MP1400	MP1400 w/Option T	MP1402	MP1402 w/Option T	MP1403	MP1403 w/Option T
1	POWER (Hot/+)	POWER (Hot/+)	POWER (Hot/+)	POWER (Hot/+)	POWER (Hot/+)	POWER (Hot/+)
2	RTD Comp Lead	No Connection	No Connection	No Connection	No Connection	No Connection
3	POWER (Neu/-)	POWER (Neu/-)	POWER (Neu/-)	POWER (Neu/-)	POWER (Neu/-)	POWER (Neu/-)
4	RTD Hi	No Connection	No Connection	No Connection	No Connection	No Connection
5	RTD Lo	No Connection	SP Pot CCW	SP Pot CCW	SP -	SP -
6	N.O.	No Connection	SP Pot W	SP Pot W	SP +	SP +
7	COM *	No Connection	SP Pot CW	SP Pot CW	No Connection	No Connection
8	N.C. *	SP Xmtr +	No Connection	SP Xmtr +	No Connection	SP Xmtr +
9	N.O.	RTD Lo	RTD Lo	RTD Lo	RTD Lo	RTD Lo
10	COM	Xmtr Common	No Connection	Xmtr Common	No Connection	Xmtr Common
11	N.C.	RTD Hi	RTD Hi	RTD Hi	RTD Hi	RTD Hi
12		Proc Xmtr +	No Connection	Proc Xmtr +	No Connection	Proc Xmtr +
13		N.O.	N.O.	N.O.	N.O.	N.O.
14		COM *	COM *	COM *	COM *	COM *
15		N.C. *	N.C. *	N.C. *	N.C. *	N.C. *
16		No Connection	No Connection	No Connection	No Connection	No Connection
17		N.O.	N.O.	N.O.	N.O.	N.O.
18		COM	COM	COM	COM	COM
19		N.C.	N.C.	N.C.	N.C.	N.C.
20		RTD Comp Lead	RTD Comp Lead	RTD Comp Lead	RTD Comp Lead	RTD Comp Lead

KEYS
 N.O. = Normally Open
 COM = Common
 N.C. = Normally Closed
 Proc = Process
 Xmtr = Transmitter
 SP = Setpoint
 W = Wiper
 CW = Clockwise
 CCW = Counterclockwise

***Pins used for Option V**
 20-pin = 14(+) - 15(-)
 11-pin = 7(+) - 8(-)

■LATCHING OUTPUT

PIN	MP1410	MP1410 w/Option T	MP1412	MP1412 w/Option T	MP1413	MP1413 w/Option T
1	POWER (Hot/+)	POWER (Hot/+)	POWER (Hot/+)	POWER (Hot/+)	POWER (Hot/+)	POWER (Hot/+)
2	No Connection	No Connection	No Connection	No Connection	No Connection	No Connection
3	POWER (Neu/-)	POWER (Neu/-)	POWER (Neu/-)	POWER (Neu/-)	POWER (Neu/-)	POWER (Neu/-)
4	Latch Reset	Latch Reset	Latch Reset	Latch Reset	Latch Reset	Latch Reset
5	No Connection	No Connection	SP Pot CCW	SP Pot CCW	SP -	SP -
6	No Connection	No Connection	SP Pot W	SP Pot W	SP +	SP +
7	No Connection	No Connection	SP Pot CW	SP Pot CW	No Connection	No Connection
8	No Connection	SP Xmtr +	No Connection	SP Xmtr +	No Connection	SP Xmtr +
9	RTD Lo	RTD Lo	RTD Lo	RTD Lo	RTD Lo	RTD Lo
10	No Connection	Xmtr Common	No Connection	Xmtr Common	No Connection	Xmtr Common
11	RTD Hi	RTD Hi	RTD Hi	RTD Hi	RTD Hi	RTD Hi
12	No Connection	Proc Xmtr +	No Connection	Proc Xmtr +	No Connection	Proc Xmtr +
13	N.O.	N.O.	N.O.	N.O.	N.O.	N.O.
14	COM *	COM *	COM *	COM *	COM *	COM *
15	N.C. *	N.C. *	N.C. *	N.C. *	N.C. *	N.C. *
16	Latch Reset	Latch Reset	Latch Reset	Latch Reset	Latch Reset	Latch Reset
17	N.O.	N.O.	N.O.	N.O.	N.O.	N.O.
18	COM	COM	COM	COM	COM	COM
19	N.C.	N.C.	N.C.	N.C.	N.C.	N.C.
20	RTD Comp Lead	RTD Comp Lead	RTD Comp Lead	RTD Comp Lead	RTD Comp Lead	RTD Comp Lead

KEYS
 N.O. = Normally Open
 COM = Common
 N.C. = Normally Closed
 Proc = Process
 Xmtr = Transmitter
 SP = Setpoint
 W = Wiper
 CW = Clockwise
 CCW = Counterclockwise

***Pins used for Option V**
 20-pin = 14(+) - 15(-)

■DUAL OUTPUT

PIN	MP1420	MP1420 w/Option T	MP1422	MP1422 w/Option T	MP1423	MP1423 w/Option T
1	POWER (Hot/+)	POWER (Hot/+)	POWER (Hot/+)	POWER (Hot/+)	POWER (Hot/+)	POWER (Hot/+)
2	RTD Comp Lead	No Connection	No Connection	No Connection	No Connection	No Connection
3	POWER (Neu/-)	POWER (Neu/-)	POWER (Neu/-)	POWER (Neu/-)	POWER (Neu/-)	POWER (Neu/-)
4	RTD Hi	No Connection	Lo SP Pot CW	Lo SP Pot CW	No Connection	No Connection
5	RTD Lo	No Connection	Lo SP Pot W	Lo SP Pot W	Lo SP +	Lo SP +
6	N.O.	Xmtr Common	SP Pots CCW	SP Pots CCW/ Xmtr Common	SP Common	SP Common/ Xmtr Common
7	COM * } Hi Set	No Connection	Hi SP Pot W	Hi SP Pot W	Hi SP +	Hi SP +
8	N.C. * }	No Connection	Hi SP Pot CW	Hi SP Pot CW	No Connection	No Connection
9	N.O.	RTD Lo	RTD Lo	RTD Lo	RTD Lo	RTD Lo
10	COM * } Lo Set	Proc Xmtr +	No Connection	Proc Xmtr +	No Connection	Proc Xmtr +
11	N.C. * }	RTD Hi	RTD Hi	RTD Hi	RTD Hi	RTD Hi
12		Lo SP Xmtr +	No Connection	Lo SP Xmtr +	No Connection	Lo SP Xmtr +
13		N.O.	N.O.	N.O.	N.O.	N.O.
14		COM * } Lo Set	COM * } Lo Set	COM * } Lo Set	COM * } Lo Set	COM * } Lo Set
15		N.C. * }	N.C. * }	N.C. * }	N.C. * }	N.C. * }
16		Hi SP Xmtr +	No Connection	Hi SP Xmtr +	No Connection	Hi SP Xmtr +
17		N.O.	N.O.	N.O.	N.O.	N.O.
18		COM * } Hi Set	COM * } Hi Set	COM * } Hi Set	COM * } Hi Set	COM * } Hi Set
19		N.C. * }	N.C. * }	N.C. * }	N.C. * }	N.C. * }
20		RTD Comp Lead	RTD Comp Lead	RTD Comp Lead	RTD Comp Lead	RTD Comp Lead

KEYS
 N.O. = Normally Open
 COM = Common
 N.C. = Normally Closed
 Proc = Process
 Xmtr = Transmitter
 SP = Setpoint
 W = Wiper
 CW = Clockwise
 CCW = Counterclockwise

***Pins used for Option V**
 20-pin:
 Hi Set = 19(+) - 18(-)
 Lo Set = 15(+) - 14(-)
 11-pin:
 Hi Set = 7(+) - 8(-)
 Lo Set = 10(+) - 11(-)

Specifications subject to change without notice.