

ELECTRONIC ACTUATOR

STEP-TOP ELECTRONIC ACTUATOR

(Linear type with Auto-setup function; Modbus communication)

Functions & Features

- Equipped stepping motor for drive motor.
- High-speed operation control (1/1000 high resolution)
- Auto set-up
- Both Modbus-RTU communication and analog signal can use
- USB (CONFIG-Type-C), PU-2x jack, and DIP switches
- Coil spring with buffer for both upper/lower end incorporated
- Equipped terminal box standardly (LEDs can be visually checked from outside)
- Manual operation function (optional)

Typical Applications

- Actuator for automatic control valve in various plants and industries
- Electronic actuator for fuel cell system and refrigerating machines

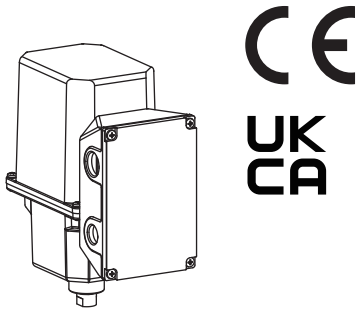

MODEL: MSP10-[1][2][3][4]-[5]CR[6]

ORDERING INFORMATION

- Code number: MSP10-[1][2][3][4]-[5]CR[6]
- Specify a code from below for each of [1] through [6].
(e.g. MSP10-1ADA-ACR/S/Q)
- Specify the specification for option code /Q
(e.g. /C03/SET)

■ FACTORY DEFAULT SETTINGS

ITEM	SETTING
Action	Reverse
Input signal	4 - 20 mA DC
Output signal	4 - 20 mA DC
Action control	Input 20 mA DC, output stem stops at the upper-stop position
Operation at abnormally low input	Stop
Upper-stop position (mm) [inch.]	0.00 [0.00]
Lower-stop position (mm) [inch.]	40.00 [1.57] 20.00 [.79]
Deadband (%)	0.1
Restart limiting timer (sec.)	0.1
Retract/UP signal position (%)	98.0
Extend/DOWN signal position (%)	2.0
Input	Analog input

[1] OUTPUT STEM OPERATION DISTANCE

1: 20mm [.79"] (adjustable to 10mm [.39"])

Max. stroke ≤ 20.0mm [.79"]

2: 40mm [1.57"] (adjustable to 20mm [.79"])

Max. stroke ≤ 40.0mm [1.57"]

[2] OPERATION TIME, THRUST, THRUST AT LOCK

■ WITH COIL FOR 700N

CODE	Sec./ 10 mm [.39"]	Sec./ 20 mm [.79"]	Sec./ 40 mm [1.57"]	THRUST	THRUST AT LOCK
A	2 sec.	3.2 sec.	5.4 sec.	450N	500N
B	2.5 sec.	4 sec.	7 sec.	600N	620N
C	3.3 sec.	5.7 sec.	10.4 sec.	740N	790N
D	4.2 sec.	7.4 sec.	13.9 sec.	780N	790N

■ WITH COIL FOR 1200N

CODE	Sec./ 10 mm [.39"]	Sec./ 20 mm [.79"]	Sec./ 40 mm [1.57"]	THRUST	THRUST AT LOCK
E	4 sec.	7 sec.	13 sec.	1200N	1500N
F	5 sec.	8.4 sec.	16.5 sec.	1300N	1500N
G	6 sec.	10 sec.	20 sec.	1400N	1500N

■ WITH COIL FOR 2500N

CODE	Sec./ 10 mm [.39"]	Sec./ 20 mm [.79"]	Sec./ 40 mm [1.57"]	THRUST	THRUST AT LOCK
H	7.4 sec.	13.5 sec.	25.5 sec.	2500N	2700N
K	8 sec.	15.2 sec.	28.4 sec.	2500N	2700N
L	9 sec.	16.5 sec.	31.5 sec.	2500N	2700N
N	10 sec.	19.5 sec.	36.8 sec.	2300N	2700N

Note: Operation time can be changed by PC configurator software or PU-2x after purchase.

Means code change in 700N / 1200N / 2500N.

However, changing from codes A and B to codes C and D is not possible (the same in reverse).

[3] OUTPUT STEM TYPE

6: M6 female thread, 0.75 pitch (fine screw)
 8: M8 female thread, 1.0 pitch (fine screw)
 1: M10 female thread, 1.25 pitch (fine screw)
 D: M6 female thread, 1.0 pitch (coarse screw)
 E: M8 female thread, 1.25 pitch (coarse screw)
 F: M10 female thread, 1.5 pitch (coarse screw)

[4] INPUT**Current**

A: 4 - 20 mA DC (Input resistance 250 Ω)

Voltage

6: 1 - 5 V DC (Input resistance 200 kΩ min.)

[5] OUTPUT**Current**

A: 4 - 20 mA DC (Load resistance 300 Ω max.)

Voltage

6: 1 - 5 V DC (Load resistance 5 kΩ min.)

CE & UKCA MARKING

C: With CE and UKCA

POWER SUPPLY VOLTAGE**DC Power**

R: 24 V DC

(Operational voltage range 24 V ±10 %, ripple 10 %p-p max.)

[6] OPTIONS (multiple selections)**Manual Operation Function**

blank: Without

/S: With

Other Options

blank: none

/Q: With options (specify the specification)

SPECIFICATIONS OF OPTION: Q (multiple selections)**COATING (For the detail, refer to our web site.)**

/CO3: Rubber coating

EX-FACTORY SETTING

/SET: Preset according to the Ordering Information Sheet
 (No. ESU-4887)

RELATED PRODUCTS

- PC configurator software (model: STCFG)
- Programming Unit (model: PU-2x)

GENERAL SPECIFICATIONS

Degree of protection: IP66

Action: "Reverse" action (switchable with DIP switch to "direct" action.)

Operation at low input:

(selectable with DIP switches)

- Move downward
- Move upward
- Stop

Low input signal level

• Current input: ≤ 1.48 (±0.2) mA DC

• Voltage input: ≤ 0.37 (±0.05) V DC

Wiring conduits: G 1/2 female thread and G 3/4 female thread (total four)

Terminal block: 7.62 mm pitch; M3 screw terminals (torque 0.5 N·m)

Screw terminal: Nickel-plated brass (not magnet)

Housing material: Diecast aluminum (ADC12)

Coating: Thermosetting acrylic resin

Coating: Silver color

Drive: Stepping motor

Insulation class: E

Position detection: Conductive potentiometer

Deadband adjustment: 0.1 - 0.5 % (1/1000 to 1/200)

Restart limiting timer adjustment: 0.1 - 5.0 sec.

Isolation: Power voltage or I/O signal to retract/UP signal position to extend/DOWN signal position to alarm signal to Modbus communication to metallic housing

Protective functions

- Automatically stops when thrust at lock (abnormal thrust increase)
- Automatically stops when surface temperature of the stepping motor is over 100°C (212°F) and automatically restarts under 95°C (203°F).
- Automatically heats to +2°C (35.6°F) when surface temperature is under 0°C (32°F). The motor continues to run.
- A heater is incorporated to use under cold areas.
- Thermostat is incorporated to automatically heat when 27°C (±5°C) (80.6°F (±9°F) or lower, and automatically stop heating when 39°C (±4°C) (102.2°F (±7.2°F)) or higher.

Status Indicator LED

- POWER: Green LED turns on when the power voltage is ON
- INPUT: Green LED turns on with normal input signal
- AUTO-SETUP: Green LED blinks while auto-setup
- MOVING UP/CCW: Green LED turns on while moving upward
- MOVING DOWN/CW: Green LED turns on while moving downward
- COM: Green LED turns ON while Modbus communication
- ALARM: Red LED blinks when abnormal operation
 (For details, refer to users manual)

User-configurable items:

Configurable with DIP switch

- Stem operation at low input
- Switching direct/reverse
- Switching signal output
- Set full-open (upper-end) position
- Set full-closed (lower-end) position
- Start/stop auto-setup

Configurable with PC or PU-2x

- Set full-open (upper-end) position
- Set full-closed (lower-end) position
- Deadband (0.1 - 0.5%)
- Restart limiting timer
- Retract/UP signal position
- Extend/DOWN signal position
- Operation speed
- Auto-setup (start/cancel)
 - Upper side contraction (distance)
 - Lower side contraction (distance)
- Specified stroke distance

Configurable with Modbus communication

- Input
 - Node address
 - Baud rate
 - Parity bit
 - Stop bit length
 - Internal terminating resistor
 - Loss of Modbus communication detection time
- Action: Switching range of reverse/direct (following table)
- Increasing input signal, output stem moves upward (reverse)
 - Increasing input signal, output stem moves downwards (direct)

● REVERSE

INPUT SIGNAL (CURRENT/VOLTAGE)	OUTPUT STEM POSITION	OUTPUT SIGNAL (CURRENT/VOLTAGE)
4 mA DC / 1 V DC	Move downward	4 mA DC / 1 V DC 20 mA DC / 5 V DC
20 mA DC / 5 V DC	Move upward	20 mA DC / 5 V DC 4 mA DC / 1 V DC

● DIRECT

INPUT SIGNAL (CURRENT/VOLTAGE)	OUTPUT STEM POSITION	OUTPUT SIGNAL (CURRENT/VOLTAGE)
20 mA DC / 5 V DC	Move downward	20 mA DC / 5 V DC 4 mA DC / 1 V DC
4 mA DC / 1 V DC	Move upward	20 mA DC / 5 V DC 4 mA DC / 1 V DC

■ MANUAL OPERATION FUNCTION (OPTIONAL)

Depends on the code of "operation time, thrust, thrust at lock"

CODE	STROKE (1 REVOLUTION)
A - G	0.27 mm
H - N	0.17 mm

MODBUS COMMUNICATION

Communication: Half-duplex, asynchronous, no procedure

Standard: TIA/EIA-485-A compatible

Transmission distance: 500 meters max.

Baud rate: 4800, 9600, 19200, 38400 bps
(ex-factory setting: 38400 bps)

Protocol: Modbus RTU

Node address: 1 to 247 (ex-factory setting: 1)

Parity: None, Odd, Even

Stop bit: 1, 2

Max. number of nodes: 31 (excluding master)

Transmission media: Shielded twisted-pair cable (CPEV-S 0.9 dia.)

Internal terminating resistor: 120 Ω

OUTPUT SPECIFICATIONS

■ Output signal

- 4-20 mA DC or 20-4 mA DC (non-isolated)
Load resistance: 300 Ω max.
- 1-5 V DC or 5-1 V DC (non-isolated)
Load resistance: 5 kΩ min.

■ Alarm output (triggered when the output stem is locked)

- Output type: Photo MOSFET relay
- Rated load: 160 V 150 mA AC/DC at peak
- ON resistance: 8 Ω max.
- Leakage current during opening/closing: 2 μA max.

STROKE RATE

Duty cycle = Within 50 %

The unit must operate at an average duty cycle of 50% (ratio of operating time to standby time) or less.

Operation rate: Less than 13 strokes / min. (excepting momentary peak stroke rate)

INSTALLATION (POWER VOLTAGE: @ 24 V DC)

Standby current value: 0.48 A (25°C^{at})

Current at no load: 0.7 A (25°C^{at})

Current at load: 1.0 A (25°C^{at})

Locked rotor current: 1.0 A (25°C^{at})

Current in standby or non-operating state at - 15°C: 0.9 A

Current at no load at - 15°C: 0.9 A

Operating temperature: -15 to +66°C (5 to 150.8°F) (No direct sunlight, radiant heat or heat transfer.)

Storage temperature: -29 to +70°C (-20.2 to 158°F)

Operating humidity: 30 to 90 %RH (non-condensing)

Vibration resistance:

- Sweep endurance test (IEC 61298-3 compliant)
- Acceleration: 19.6 m/s² (2 G)
- Frequency: 10 to 1000 Hz
- Cycle: 20 cycles
- Sweep rate: 1 oct./min.
- Testing time: approx. 4 hr. 30 min.
- Direction: X, Y, Z

Mounting orientation:

DO NOT mount upside-down

Weight: Approx. 4 kg (8.820 lb)

PERFORMANCE

Resolution: 0.02 mm (1/1000 at 20 mm setting)

Hysteresis: 0.6%

Linear characteristic: 0.6%

Backlash: 0.2 mm

Insulation resistance: ≥ 100 MΩ with 500 V DC
(Power voltage or I/O signal to retract/UP signal to extend/DOWN signal to alarm signal to Modbus communication to metallic housing)

Dielectric strength: 500 V AC @ 1 minute (or 600 V AC @ 1 second)

(Power voltage or I/O signal to retract/UP signal to extend/DOWN signal to alarm signal to communication to metallic housing)

STANDARDS & APPROVALS

■ EU conformity (CE marking)

- EMC Directive
EMI EN 61000-6-4
EMS EN 61000-6-2

RoHS Directive
EN IEC 63000

■ UK conformity (UKCA marking)

The UK legislations and designated standards equivalent to the applicable EU directives.

TERMINOLOGY

• Auto-setup Function

A function that automatically set the position that keeps constant thrust load at low-end (closed) with a single operation.

Auto-setup can be performed by following 3 types: Switching DIP SW, PU-2x, and PC configurator software (USB -Type-C).

Even if a leak occurs, the closed position can be changed in 0.1 mm.

• Modbus communication

Operation status of the actuator can be monitored during normal operation for ensuring safe operation of the product and supporting equipment maintenance.

Via Modbus communication, the following data can be monitored to grasp the operation status of the actuator.

- No. of times of start actions of the stepping motor
- No. of times of reverse actions of the stepping motor
- Accumulated operating time of the stepping motor
- Accumulated operation distance of the output stem
- No. of times of restart when an excessive thrust error occurs
- Excessive thrust error

• Excessive thrust monitoring

Function to stop the stepping motor when an excessive thrust is detected. Specifically, the unit constantly monitors the position of the output stem while the stepping motor is driven. When the unit detects that the output stem is not following the position detecting value of the potentiometer, tries to operate with max value of set thrust. If the output stem does not follow the motor after two times, an error of excessive thrust occurs and the stepping motor is stopped (alarm signal). To release the alarm signal, turn off the power voltage.

• Deadband

Linear resolution

• Hysteresis

The output stem reciprocates i.e. moves up and down according to the input signal. Hysteresis is the difference between the two curves of ascending and descending directions, which is expressed in percentage.

• Linear Characteristics

The output stem reciprocates i.e. moves up and down according to the input signal. In theory, the output stem moves by a distance proportional to the input signal. In the case of MSP, the difference between the theoretical value and the actual distance that the output stem actually moved is expressed in percentage.

• Restart Limiting Timer

This function prevents the output stem operates frequently when the input signal is unstable. To prevent the output stem operates frequently, it does not operate at the moment the input signal changes, but after a set period of time.

• Coil spring (thrust buffering function)

Coil spring is incorporated in the unit (output stem)

position).

Elasticity of the coil spring buffers thrust that affects to the valve system.

• **Output stem operation distance**

20 mm type means maximum operation distance.

Use 40 mm type if 21 mm of operation distance is required.

40 mm type also means maximum operation distance.

Both 20 m type and 40 mm type are max lower-end position.

Operation distance cannot be extended longer than 40 mm.

TERMINAL CONNECTIONS

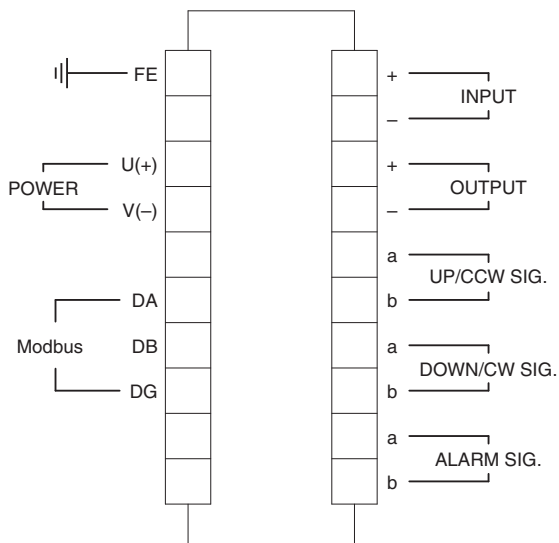

COMMUNICATION CABLE CONNECTIONS

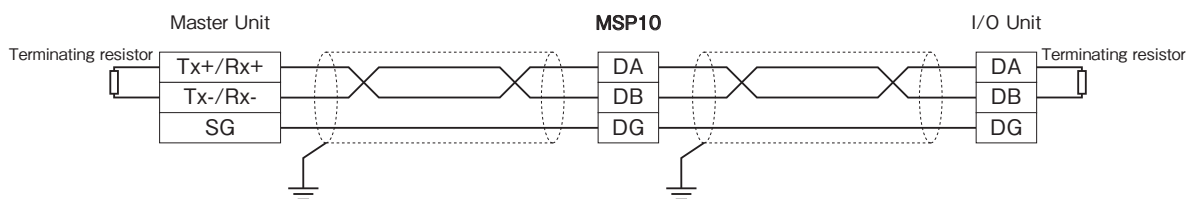

Terminating resistors can be turned ON/OFF on the PC configurator software (model: STCFG) or programming unit (model: PU-2x).

EXTERNAL DIMENSIONS unit: mm [inch]

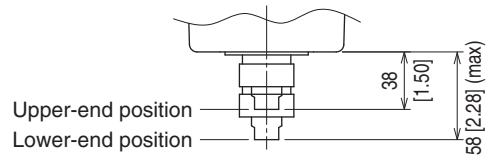
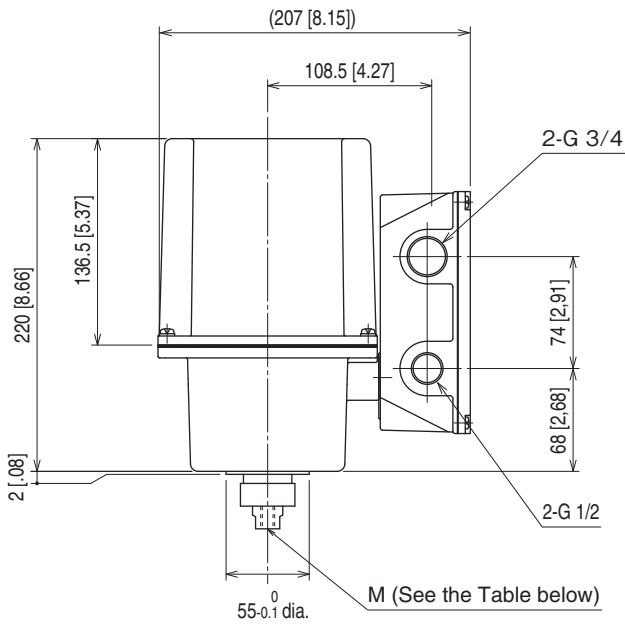
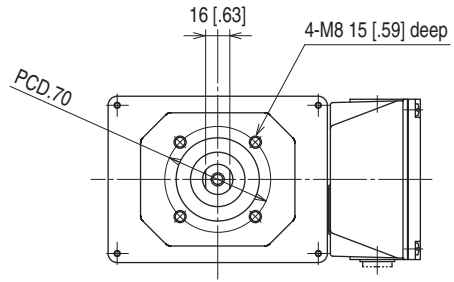
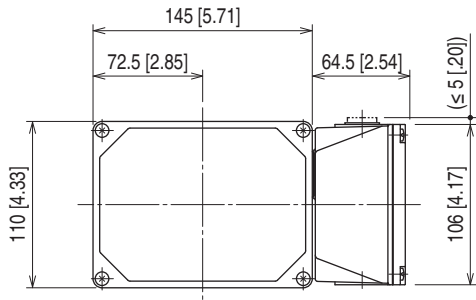

For stroke 20 mm [0.79]

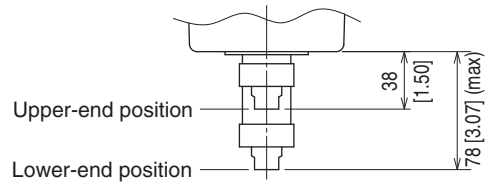

For stroke 40 mm [1.57]

■ FOR THE MODEL WITH MANUAL OPERATION FUNCTION

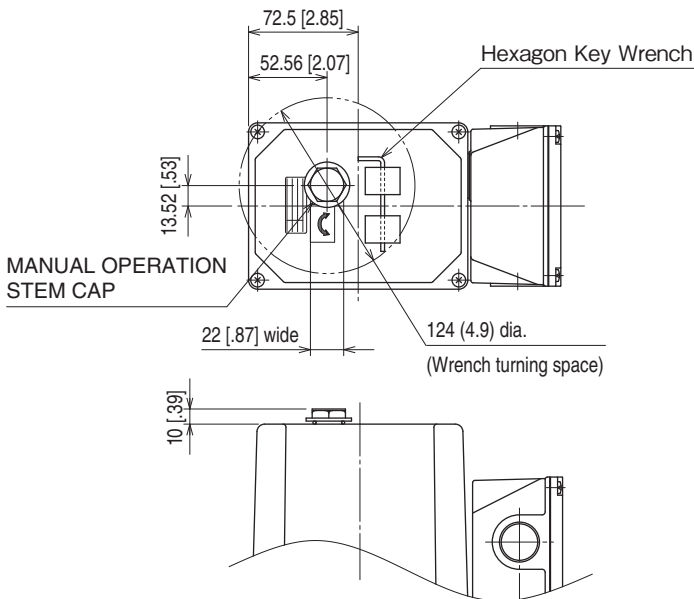

OUTPUT STEM HOLE SIZE M

CODE	DIA.	PITCH	DEPTH
6	M 6	0.75	15
8	M 8	1.0	
1	M10	1.25	
D	M 6	1.0	
E	M 8	1.25	
F	M10	1.5	

SCHEMATIC CIRCUITRY & CONNECTION DIAGRAM

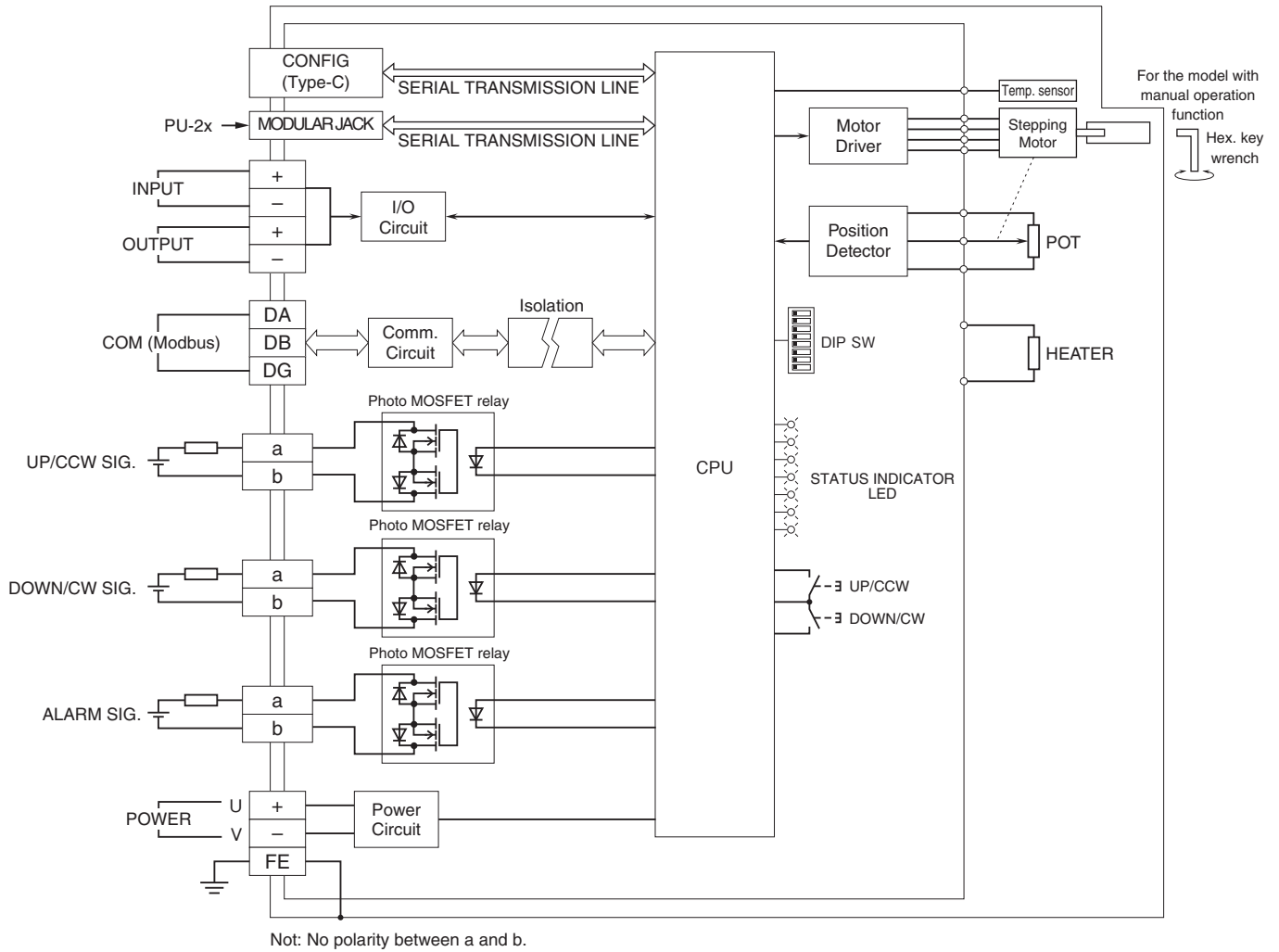

Specifications are subject to change without notice.