

Final Control Elements

MINI-TOP ELECTRONIC ACTUATOR

(linear type; CC-Link)

Functions & Features

- Small-size control valve actuator
- Direct connection to CC-Link capable PLC and other devices on the same network
- Easy wired
- Uploading device information via CC-Link for maintenance purpose
- 1/1000 high resolution

Typical Applications

- For small size proportional control valve in paper manufacturing or co-generation system
- Air conditioning for buildings and factories
- Chemical injection at water treatment plant

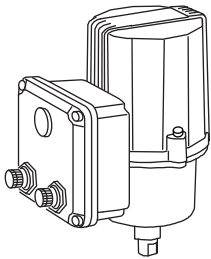

MODEL: MSP4C-[1][2][3]-OR

ORDERING INFORMATION

- Code number: MSP4C-[1][2][3]-OR
- Specify a code from below for each of [1] through [3].
(e.g. MSP4C-271-OR)

[1] STROKE

- 1: 5 to 10 mm (.20" to .39")
2: 8 to 15 mm (.31" to .59")

[2] OPERATION TIME, THRUST

- 3: 5 sec. / 10 mm, 150 N
4: 9 sec. / 10 mm, 300 N
7: 18 sec. / 10 mm, 700 N

[3] OUTPUT STEM TYPE

- 5: M5 female thread, 0.5 pitch
6: M6 female thread, 0.75 pitch
8: M8 female thread, 1.0 pitch

- 1: M10 female thread, 1.25 pitch
C: M5 female thread, 0.8 pitch
D: M6 female thread, 1.0 pitch
E: M8 female thread, 1.25 pitch
F: M10 female thread, 1.5 pitch
S: Stem button

CE MARKING

0: Without

POWER INPUT

DC Power

R: 24 V DC

(Operational voltage range 24 V \pm 10 %, ripple 10 %p-p max.)

GENERAL SPECIFICATIONS

Degree of protection: IP66

Operation at a communication error: Extend, retract or stop

Power circuit connection: 4-core microconnector, male

Power cable: Cable with connector (e.g. OMRON XS2F or XS2WD42)

Transmission cable: Conforms to CC-Link

(TE Connectivity TAA545 or Phoenix Contact SAC-4P)

Housing material: Cast aluminum

Drive: Stepping motor

Insulation class: E

Position detection: Potentiometer

Deadband: 0.1 - 1.9 % adjustable (factory set to 1.5 %)

Restarting timer: 0 - 10 sec. adjustable

(factory set to 1.5 sec.)

Isolation: Housing or communication to power

Zero adjustment: 0 - 25 %

Span adjustment: 50 - 100 %

Protective functions: Overload protection

Status indicator LED: Red light blinks in 2 sec. intervals in normal operations; blinks in 0.5 sec. intervals when a foreign object is detected mechanically caught inside.

Manual operating handle: Not available

CC-Link COMMUNICATION

Protocol: CC-Link V1.10

Device type: Remote device station

Station No. setting: Rotary switch; 1 - 64

Required node: 1

Baud rate setting: Rotary switch

L RUN indicator: Red LED

L ERR. indicator: Red LED

OUTPUT SPECIFICATIONS

■ Operation Time & Torque (at rated power voltage)

[Model: Operation Time: Thrust]

MSP4C-x3: 5 sec. / 10 mm: 150 N (33.5 lbf)

MSP4C-x4: 9 sec. / 10 mm: 300 N (67 lbf)

MSP4C-x7: 18 sec. / 10 mm: 700 N (157 lbf)

INSTALLATION

Current consumption

•DC: Approx. 0.5 A

Operating temperature: -5 to +55°C (23 to 131°F)

Operating humidity: 30 to 85 %RH (non-condensing)

Vibration: 0.5 G (4.9 m/s²) max.

Mounting position: All directions

Do not mount the actuator with its output stem or cable connector on the upside if the actuator is to be exposed to dripping water.

Weight: 1.5 kg (3.3 lb)

PERFORMANCE

Resolution: 1/1000 or 0.015 mm, whichever is greater, with 0.1 % deadband setting

Insulation resistance: $\geq 100 \text{ M}\Omega$ with 100 V DC

Dielectric strength: 100 V AC @ 1 minute
(housing or communication to power)

COMMUNICATIONS

■ MASTER to SLAVE

DATA TYPE	ADDRESS	FUNCTION	DETAIL
Bit	RY0	Forced Closed Position Input *1	0 : Disable 1 : Position = 0%
	RY1	Forced Open Position Input *1	0 : Disable 1 : Position = 100%
	RY2		
	RY3		
	RY4		
	RY5		
	RY6		
	RY7		
	RY8	Enable Target Position Input	0 : Disable 1 : Enable
	RY9		
	RYA	Reset Motor Deadlock Alarm	Motor deadlock alarm is cancelled when '1' is set.
	RYB	Clear Motor Starting Counter	Motor starting counter is reset to 0 when '1' is set.
	RYC	Clear Motor Reversing Counter	Motor reversing counter is reset to 0 when '1' is set.
	RYD	Clear Accumulated Running Distance	Accumulated running distance is reset to 0 when '1' is set.
	RYE		
RYF			
Word	RWw0	Target Position Input	Signed, 0.01% increments (e.g. 100 = 1.00%) Valid only when Enable Target Position Input is enabled.
	RWw1		
	RWw2		
	RWw3		

*1. Valid regardless of the RY8 (Enable Target Position Input) status. Stopped when '1' is set both at RY0 and RY1.

■ SLAVE to MASTER

DATA TYPE	ADDRESS	FUNCTION	DETAIL
Bit	RX0		
	RX1		
	RX2		
	RX3		
	RX4		
	RX5		
	RX6		
	RX7		
	RX8	Motor Deadlock Alarm	0 : Normal 1 : Overload or other deadlock alarm
	RX9	Target Position Input Error	0 : Normal 1 : Out of range from -0.5 to +100.5%
	RXA	System Error	0 : Normal 1 : Memory or other system error
	RXB	Control Status	0 : Remote (CC-Link) 1 : Manual
	RXC		
	RXD		
	RXE		
RXF			
Word	RWr0	Position Output	Signed, 0.01% increments (e.g. 100 = 1.00%)
	RWr1	Motor Starting Counter *2	1 count per every 100 starting actions
	RWr2	Motor Reversing Counter *2	1 count per every 100 reversing actions
	RWr3	Accumulated Running Distance (%) *2	1 count per running 100% distance every time

*2. When the count reaches 65535, the value is held until it is reset.

EXTERNAL DIMENSIONS unit: mm [inch]

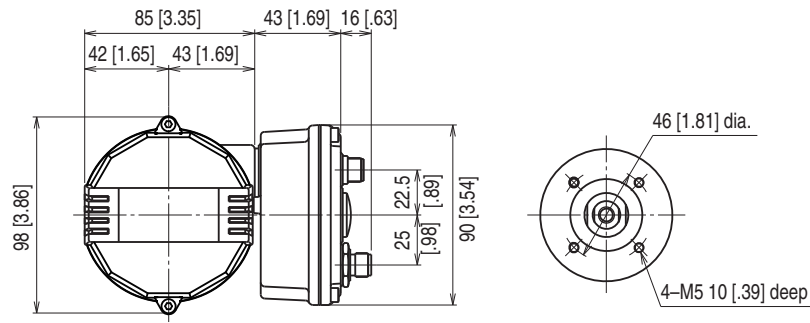

YOKE CONNECTION

OUTPUT STEM HOLE SIZE M			
CODE	DIA.	PITCH	DEPTH
5	M 5	0.5	15
6	M 6	0.75	15
8	M 8	1.0	15
1	M 10	1.25	15
C	M 5	0.8	15
D	M 6	1.0	15
E	M 8	1.25	15
F	M 10	1.5	15

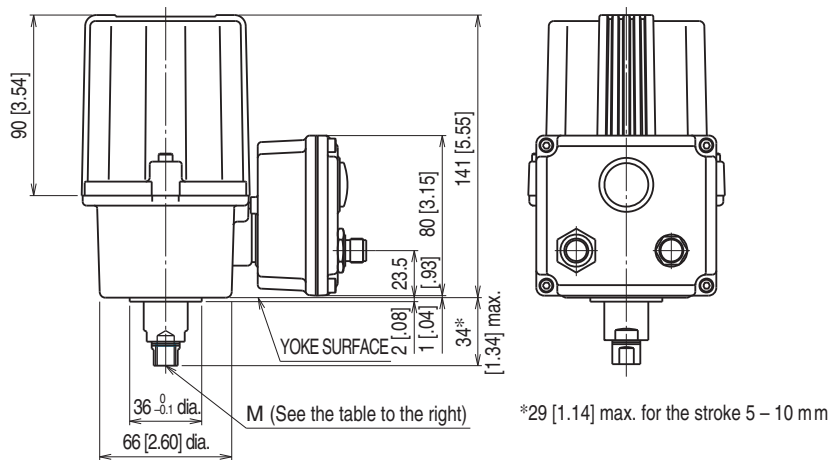

OUTPUT STEM BUTTON

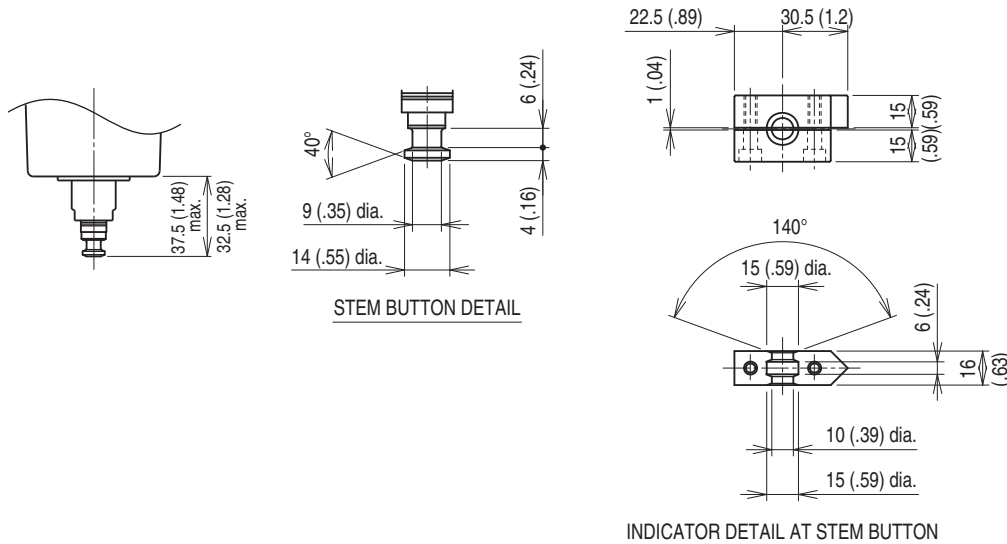

SCHEMATIC CIRCUITRY

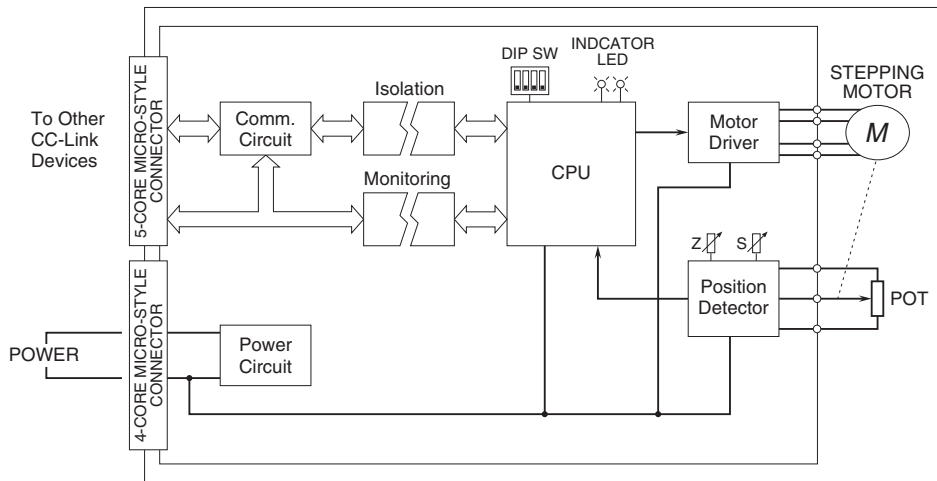

Specifications are subject to change without notice.