

Plug-in Signal Conditioners MX-UNIT

STRAIN GAUGE TRANSMITTER

(front configurable, high speed, excitation 12 V 120 mA)

Functions & Features

- Provides a DC output signal proportional to a bridge type strain gauge utilized in load cells and pressure transducers
- Compatibility with strain gauges of various bridge resistances and output ratings
- Supplies required excitation voltage; 0.1 - 12.0 V adjustable; $\geq 85 \Omega$, $\leq 120 \text{ mA}$
- Wide-range adjustments: 0 - 100 % for zero and gain
- Response time ≤ 10 milliseconds
- Isolation up to 2000 V AC
- Loop test output

Typical Applications

- Weighing system for tanks, hoppers and silos
- Weighing system using cranes
- Pressure sensor utilizing strain gauges
- Float level meter utilizing strain gauges

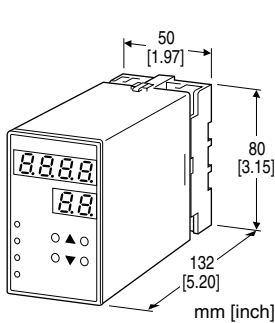

MODEL: MXLCF-[1][2]-[3][4]

ORDERING INFORMATION

- Code number: MXLCF-[1][2]-[3][4]
- Specify a code from below for each of [1] through [4].
(e.g. MXLCF-S1V1-M2/Q)
- Specify the specification for option code /Q
(e.g. /C01/S01/SET)

[1] INPUT STRAIN GAUGE

- S1:** 0.0 - 1.0 mV/V
- S2:** 0.0 - 3.0 mV/V
- S3:** 0.0 - 10.0 mV/V
- S4:** 0.0 - 30.0 mV/V

[2] OUTPUT

Current

Z1: Range 0 - 20 mA DC (Load resistance 600 Ω max.)

Voltage

V1: Range -1 - +1 V DC (Load resistance 1000 Ω min.)

V2: Range -10 - +10 V DC (Load resistance 10k Ω min.)

[3] POWER INPUT

AC Power

M2: 100 - 240 V AC (Operational voltage range 85 - 264 V, 47 - 66 Hz)

DC Power

R: 24 V DC

(Operational voltage range 24 V ± 10 %, ripple 10 %p-p max.)

P: 110 V DC

(Operational voltage range 85 - 150 V, ripple 10 %p-p max.)

[4] OPTIONS

blank: none

/Q: With options (specify the specification)

SPECIFICATIONS OF OPTION: Q (multiple selections)

COATING (For the detail, refer to our web site.)

/C01: Silicone coating

/C02: Polyurethane coating

/C03: Rubber coating

TERMINAL SCREW MATERIAL

/S01: Stainless steel

EX-FACTORY SETTING

/SET: Preset according to the Ordering Information Sheet
(No. ESU-1705)

GENERAL SPECIFICATIONS

Construction: Plug-in

Connection: M3.5 screw terminals

Screw terminal: Chromated steel (standard) or stainless steel

Housing material: Flame-resistant resin (black)

Isolation: Input to output to power

Overrange output: Approx. -15 to +115 %

Excitation adjustment: 0.1 - 12.0 V (front)

Zero adjustment: 0 - 100 % (front)

Gain adjustment: 0 - 9.99 (front)

Tare adjustment: -999.9 - 999.9 % (front or by external contact)

Programming: Via front keys

- Scaled range
- Moving average
- etc...

(Refer to the instruction manual for details)

■ DISPLAY

LED: 8 mm (.31") 7 segment, red

Number of display digits: 4 digits for DATA display; 2 digits for ITEM display

Scaling: -9999 to 9999

(decimal point position selectable)

PV indication: Input signal in engineering unit

Overrange indication: LEDs blinking

Power saving mode: Displays turn off if the keys are untouched for a preset time period

LEDs: Red, PL1 turns on with negative polarity, PL4 turns on with contact input on.

INPUT SPECIFICATIONS

■ Strain Gauge Input

• Strain Gauge

Sensor sensitivity setting

S1: 0.0010 - 0.9999mV/V

S2: 0.010 - 3.000mV/V

S3: 0.010 - 9.999mV/V

S4: 0.10 - 30.00mV/V

Sensor sensitivity setting min. step:

S1: 0.0001 mV/V

S2: 0.001 mV/V

S3: 0.001 mV/V

S4: 0.01 mV/V

Default setting:

S1: 0.9999 mV/V

S2: 3.000 mV/V

S3: 9.999 mV/V

S4: 30.00 mV/V

Rated output from strain gauge:

S1: -9.999 - +9.999 mV, span 1.000 - 9.999 mV

S2: -30.00 - +30.00 mV, span 3.00 - 30.00 mV

S3: -99.99 - +99.99 mV, span 10.00 - 99.99 mV

S4: -300.0 - +300.0 mV, span 30.0 - 300.0 mV

Input voltage setting min. step:

S1: 0.001 mV

S2: 0.01 mV

S3: 0.01 mV

S4: 0.1 mV

Note: Consult factory for use with a compression/tension load cells.

• **Excitation:** 0.1 - 12.0 V adjustable (0.1 V increments)

Maximum current: 120 mA

Load resistance: 85 Ω minimum

Default setting: 1.0 V

■ **Contact Input:** TTL level (5V-CMOS level), open collector or dry contact (detecting voltage: approx. 5 V, saturation voltage: ≤ 1 V, sink current: 0.5 mA)

OUTPUT SPECIFICATIONS

■ **DC Current:** 0.0 - 20.0 mA DC

Operational range: 0.0 - 24.0 mA DC

Minimum increment: 0.1 mA

Default setting: 4.0 - 20.0 mA DC

■ DC Voltage

Code V1: -1.00 - +1.00 V DC

Operational range: -1.15 - +1.15 V DC

Minimum increment: 10 mV

Code V2: -10.0 - +10.0 V DC

Operational range: -11.5 - +11.5 V DC

Minimum increment: 100 mV

Note: Set to the 100 % output with a larger value than the 0 % output value.

Default setting:

Code V1: -1.00 - +1.00 V DC

Code V2: -10.0 - +10.0 V DC

INSTALLATION

Power consumption

•AC: Approx. 16 VA

•DC: Approx. 7 W

Operating temperature: -5 to +55°C (23 to 131°F)

Operating humidity: 30 to 90 %RH (non-condensing)

Mounting: Surface or DIN rail

Weight: 450 g (0.99 lb)

PERFORMANCE

Moving average in 64 samples

Accuracy: Input + output

Input: ±0.1 %

Output: ±0.1 %

Min. span required to ensure the accuracy: 20 % of the selectable input and output range.

Display accuracy: Input accuracy ±1 digit (with 0.0 - 100.0 scaling)

Temp. coefficient: ±0.015 %/°C (±0.008 %/°F)

Response time: (0 - 90 %)

Moving Average:

Without: Approx. 5 msec.

4 samples: Approx. 10 msec.

8 samples: Approx. 15 msec.

16 samples: Approx. 20 msec.

32 samples: Approx. 40 msec.

64 samples: Approx. 70 msec.

Excitation: Set value ±250 mV

Line voltage effect: ±0.1 % over voltage range

Insulation resistance: ≥ 100 MΩ with 500 V DC

Dielectric strength: 2000 V AC @1 minute (input to output to power to ground)

STANDARDS & APPROVALS

EU conformity:

EMC Directive

EMI EN 61000-6-4

EMS EN 61000-6-2

Low Voltage Directive

EN 61010-1

Installation Category II

Pollution Degree 2

Input to output to power: Basic insulation (300 V)

RoHS Directive

EXTERNAL VIEW

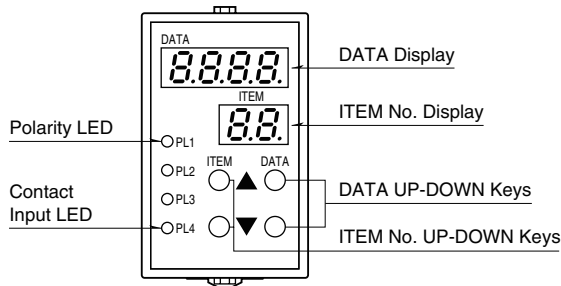

Refer to the instruction manual for detailed procedures.

EXTERNAL DIMENSIONS & TERMINAL ASSIGNMENTS unit: mm [inch]

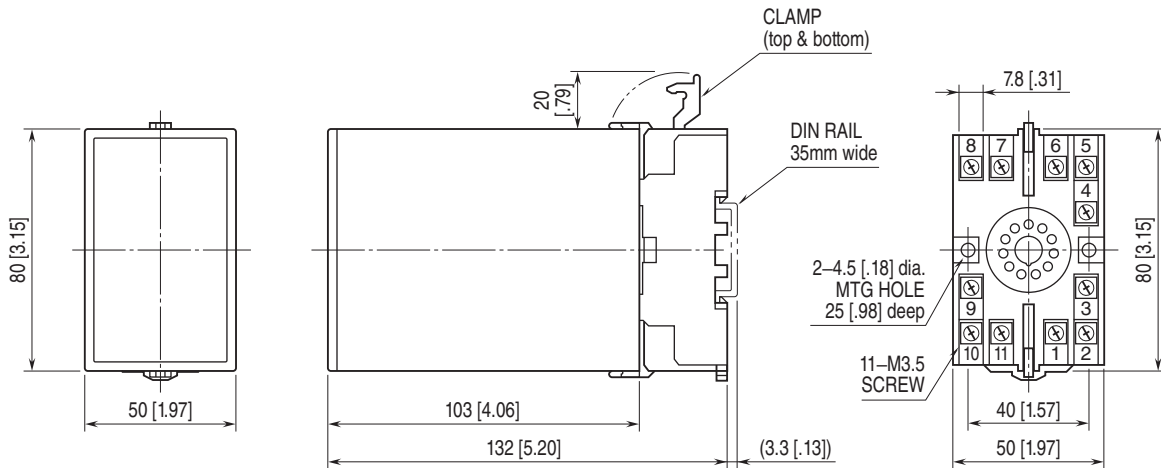

• When mounting, no extra space is needed between units.

SCHEMATIC CIRCUITRY & CONNECTION DIAGRAM

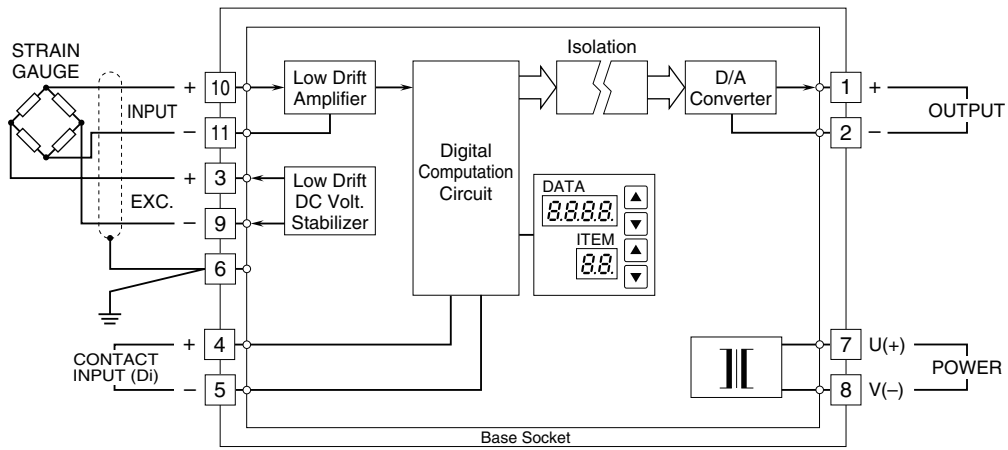

Specifications are subject to change without notice.