

2 Channel Super-mini Signal Conditioners with Display M1E-2 Series

RTD TRANSMITTER

(2 channels, PC programmable)

Functions & Features

- Accepts direct input from a RTD and provides a linearized process signal
- Wide selection of RTD
- 2 channels
- Adjustments with the front buttons
- Leadwire resistance compensation
- OEL display with good visibility

Typical Applications

- Long distance transmission between the RTD and the transmitter

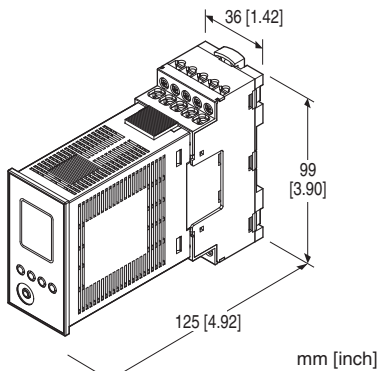

Note: The figure shows the combination of the unit and the base.

MODEL: M1EXR-2-[1][2]

ORDERING INFORMATION

- Code number: M1EXR-2-[1][2]
- Specify a code from below for each of [1] and [2].
(e.g. M1EXR-2-M2/Q)
- Specify the specification for option code /Q
(e.g. /C01/SET)

NO. OF CHANNELS

2: 2 channels

INPUT - Field-selectable

RTD

JPt 100 (JIS'89), Pt 100 (JIS'89), Pt 100 (JIS'97, IEC), Pt 50Ω (JIS'81), Ni 508.4Ω, Pt 1000, Ni 100, Cu 10 @ 25°C

OUTPUT - Field-selectable

◆ DC Output

- Current output: 0 - 20 mA DC
- Voltage output: -5 - +5 V DC
- Voltage output: -10 - +10 V DC

[1] POWER INPUT

AC Power

M2: 100 - 240 V AC (Operational voltage range 85 - 264 V, 47 - 66 Hz)

DC Power

R: 24 V DC

(Operational voltage range 24 V ±10 %, ripple 10 %p-p max.)

P: 110 V DC

(Operational voltage range 85 - 150 V, ripple 10 %p-p max.)

[2] OPTIONS

blank: none

/Q: With options (specify the specification)

SPECIFICATIONS OF OPTION: Q (multiple selections)

COATING (For the detail, refer to our web site.)

/C01: Silicone coating

/C02: Polyurethane coating

/C03: Rubber coating

EX-FACTORY SETTING

/SET: Preset according to the Ordering Information Sheet (No. ESU-5984)

RELATED PRODUCTS

- Installation base (model: M1E-BS2)
 - PC Configurator cable (model: MCN-CON or COP-US)
 - M1E configurator software (model: M1ECFG)
- Downloadable at our web site.

GENERAL SPECIFICATIONS

Construction: Plug-in

Connection

- Connected to base with connector

- Base

M2.6 screw terminals (torque: 0.5 N·m)

Applicable solderless terminal size (M3)

Screw terminal: Nickel-plated steel

Housing material: Flame-resistant resin (black)

Isolation: Ch1 input to Ch2 input to Ch1 output to Ch2 output to power

Overrange output: Approx. -10 to +110 % (Not available for current output not greater than 0 mA)

Input zero fine adj. range: -10 to +10°C (front button)

Input span fine adj. range: -10 to +10°C (front button)

Output zero fine adj. range: -5 to +5% (front button)
Output span fine adj. range: 95 to 105% (front button)
Burnout protection: Upscale standard; downscale or no burnout optional by programming
Configuration: Program with front buttons or Via PC.
Programmable features include: Refer to the parameter list.
Configurator connection: 2.5 dia. miniature jack;
 RS-232-C level

■ **Recommended solderless terminal size - M3 (unit: mm)**

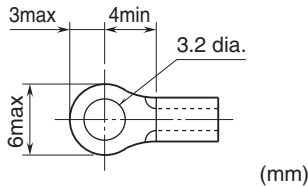

DISPLAY

Display functions: Displays and sets measured range, engineering unit
Display size: Approx. 15.6 × 20.8 mm (0.61" × 0.82")
Number of pixels: 68 × 95 (horizontal × vertical)
Character color: Yellow
Display life: Approx. 50000 hours
 (Expected time for the Display brightness to be reduced to 50 % when the Display is used continuously with brightness setting 2 in 25 °C)
Display type: OEL display
Display digit: Negative 5 digits, positive 6 digits (-99999 to 999999)
Decimal point position: None, number of decimal places 1 or 2

INPUT SPECIFICATIONS

Input: 2- or 3-wire RTD
Maximum leadwire resistance: 50 Ω per wire (For Cu 10, 20 Ω per wire)
Sensing current:
 Pt 100, JPt 100, Pt 50 Ω, Ni 100, Cu 10: approx. 1.0 mA
 Pt 1000, Ni 508.4 Ω: approx. 0.2 mA
Measurement rang: -5 to +105% of input setting value
 Refer to the operating manual (EM-5984-B) for changing input range, setting value.

OUTPUT SPECIFICATIONS

■ **DC Current**
Output range: 0 - 20 mA DC
Conformance range: 0 - 22mA DC
Minimum span: 1 mA
Load resistance: Output drive 15 V max.
 (e.g. 4 - 20 mA: 750 Ω [15 V ÷ 20 mA])

(Not available to output less than 0 mA, output range may not be extended to -5 %)

■ **DC Voltage**

Output range: -5 - +5 V DC, -10 - +10 V DC
Conformance range: -6 - +6 V DC, -12 - +12 V DC
Minimum span: 250 mV, 1 V
Load resistance: 200 kΩ min.

INSTALLATION

Power Consumption

• **AC:**
 ≤ 7 VA at 100 V
 ≤ 10 VA at 200 V
 ≤ 12 VA at 264 V
 • **DC:** ≤ 4 W

Operating temperature: -5 to +55°C (23 to 131°F)
Storage temperature: -5 to +55°C (23 to 131°F)
Operating humidity: 10 to 85 %RH (non-condensing)
Mounting: Surface or DIN rail
Weight: 120 g (0.26 lb) except base

PERFORMANCE

Accuracy: Input accuracy + output accuracy
 See CALCULATION EXAMPLES OF OVERALL ACCURACY.
 Inversely proportional to the setting span.
Input accuracy: (whichever is greater)
 Table 1 accuracy value or ±0.1 % of FS
Display accuracy:
 Input display: Input accuracy ±1 digit
 Output display: Input accuracy + output accuracy ±1 digit
Output accuracy: (% of max. output range)
 0 - 20 mA: ±0.06 %
 -5 - +5 V: ±0.03 %
 -10 - +10 V: ±0.03 %
Temp. coefficient (% of max. I/O range): ±0.015 %/°C
 (±0.008 %/°F)
Response time (filter time constant: 0 sec.): ≤ 0.5 sec.
 (0 - 90 %)
Burnout response: ≤ 10 sec.
Line voltage effect: ±0.1 % over voltage range
Insulation resistance: ≥ 100 MΩ with 500 V DC
Dielectric strength: 1500 V AC @ 1 minute
 (Ch1 input to Ch2 input to Ch1 output to Ch2 output to power to ground)

CALCULATION EXAMPLES OF OVERALL ACCURACY

[Example] Input Range Pt 100 (JIS'97, IEC), 0 - 100°C, Output Range 0 - 20 mA, Output Setting 4 - 20 mA

■ Overall accuracy

- Input Accuracy

$$100\text{ °C} \times 0.1\% = 0.1\text{ °C}$$

0.2 °C is higher thus 0.2 °C is selected

$$0.2\text{ °C} \div 100\text{ °C} = 0.2\%$$

- Output Accuracy = Output Range Span (20 mA) ÷ Output Span Setting (16 mA) × 0.06 % = 0.075 %

$$\text{Overall Accuracy} = 0.2 + 0.075 = \pm 0.275\%$$

[Table 1]

INPUT RANGE	°C		
	MINIMUM SPAN	SETTING RANGE	ACCURACY
JPt 100 (JIS' 89)	20	-200.00 to +500.00	±0.5 (±0.2°C, when set with the range of -200.00 to +200.00°C)
Pt 100 (JIS' 89)	20	-200.00 to +650.00	±0.5 (±0.2°C, when set with the range of -200.00 to +200.00°C)
Pt 100 (JIS' 97, IEC)	20	-200.00 to +850.00	±0.5 (±0.2°C, when set with the range of -200.00 to +200.00°C)
Pt 50 Ω (JIS' 81)	20	-200.00 to +649.00	±0.8
Ni 508.4 Ω	20	-50.00 to +200.00	±0.8
Pt 1000	20	-200.00 to +850.00	±0.8
Ni 100	20	-50.00 to +200.00	±0.8
Cu 10 @ 25°C	20	-50.00 to +250.00	±1.0
INPUT RANGE	°F		
	MINIMUM SPAN	SETTING RANGE	ACCURACY
JPt 100 (JIS' 89)	36	-328.00 to +932.00	±0.90 (±0.36°F, when set with the range of -328.00 to +392.00°F)
Pt 100 (JIS' 89)	36	-328.00 to +1202.00	±0.90 (±0.36°F, when set with the range of -328.00 to +392.00°F)
Pt 100 (JIS' 97, IEC)	36	-328.00 to +1562.00	±0.90 (±0.36°F, when set with the range of -328.00 to +392.00°F)
Pt 50 Ω (JIS' 81)	36	-328.00 to +1200.20	±1.44
Ni 508.4 Ω	36	-58.00 to +392.00	±1.44
Pt 1000	36	-328.00 to +1562.00	±1.44
Ni 100	36	-58.00 to +392.00	±1.44
Cu 10 @ 25°C	36	-58.00 to +482.00	±1.80
INPUT RANGE	K		
	MINIMUM SPAN	SETTING RANGE	ACCURACY
JPt 100 (JIS' 89)	20	73.15 to 773.15	±0.5 (±0.2K, when set with the range of 73.15 to 473.15K)
Pt 100 (JIS' 89)	20	73.15 to 923.15	±0.5 (±0.2K, when set with the range of 73.15 to 473.15K)
Pt 100 (JIS' 97, IEC)	20	73.15 to 1123.15	±0.5 (±0.2K, when set with the range of 73.15 to 473.15K)
Pt 50 Ω (JIS' 81)	20	73.15 to 922.15	±0.8
Ni 508.4 Ω	20	223.15 to 473.15	±0.8
Pt 1000	20	73.15 to 1123.15	±0.8
Ni 100	20	223.15 to 473.15	±0.8
Cu 10 @ 25°C	20	223.15 to 523.15	±1.0

STANDARDS & APPROVALS

EU conformity:

EMC Directive

EMI EN 61000-6-4

EMS EN 61000-6-2

Low Voltage Directive

EN 61010-1

Installation Category II

Pollution Degree 2

Input or output to power: Reinforced insulation (300 V)

RoHS Directive

EXTERNAL VIEW

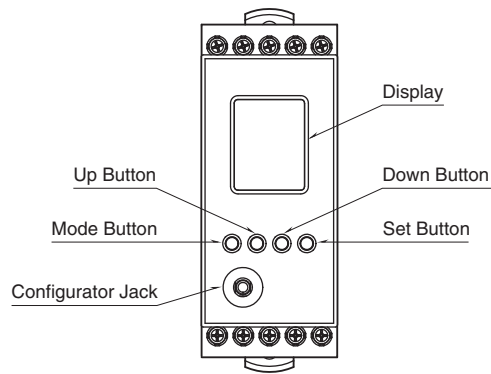

COMPONENT	FUNCTION
Display	Indicates present values, setting values and abnormal information. Two types of present values are displayed respectively at the upper and lower parts according to setting.
Mode button	Shifts from Measuring mode to each setting mode. The destination changes depending on how long the button is held down. Pressing Mode button for ≥ 2 seconds returns to Measuring mode from each setting mode.
Set button	Shifts the setting value of each setting parameter item to a setting changeable state. When at setting changeable state, used to move through the digits of setting value and to enter (save) the setting value.
Up button	Shifts through setting parameter items and to increase or select the setting value.
Down button	Shifts through setting parameter items and to decrease or select the setting value.
Configurator Jack	Used to perform configuration with M1E configurator software (model: M1ECFG). When using the software, set the Lockout setting of the unit to 'Lock'.

Refer to the operating manual (EM-5984-B) for detailed procedures.

TERMINAL ASSIGNMENTS

1	2	3	4	5
6	7	8	9	10
11	12	13	14	15
16	17	18	19	20

No.	FUNCTION	No.	FUNCTION
1	Unused	11	Ch1 Output +
2	Unused	12	Ch1 Output -
3	Ch1 Input A	13	Unused
4	Ch1 Input B (3-wire)	14	Ch2 Output +
5	Ch1 Input B	15	Ch2 Output -
6	Unused	16	Unused
7	Unused	17	Unused
8	Ch2 Input A	18	Unused
9	Ch2 Input B (3-wire)	19	Power U (+)
10	Ch2 Input B	20	Power V (-)

*** Base does not come with the unit. Please order separately.**

PARAMETER LIST

It is available to configure or confirm settings shown below by using front button. Configuring or confirming with PC is available when using M1E configurator software (model: M1ECFG).

MODE	ITEM	SETTING PARAMETER	RANGE	UNIT	INITIAL VALUE
Ch1 setting	01	Lockout setting	Lock / Unlock	—	Lock
	09	Ch1 Temperature unit	°C / °F / K	—	°C
	11	Ch1 Input range	JPt 100 (JIS '89) Pt 100 (JIS '89) Pt 100 (JIS '97, IEC) Pt 50 Ω (JIS '81) Ni 508.4 Ω Pt 1000 Ni 100 Cu 10 @ 25°C	—	Pt 100 (JIS '97, IEC)
	12	Ch1 0 % input setting	JPt 100 (JIS '89) : -200.00 – 480.00 Pt 100 (JIS '89) : -200.00 – 630.00 Pt 100 (JIS '97, IEC) : -200.00 – 830.00 Pt 50 Ω (JIS '81) : -200.00 – 629.00 Ni 508.4 Ω : -50.00 – 180.00 Pt 1000 : -200.00 – 830.00 Ni 100 : -50.00 – 180.00 Cu 10 @ 25°C : -50.00 – 230.00	°C	0.0
	13	Ch1 100 % input setting	JPt 100 (JIS '89) : -180.00 – 500.00 Pt 100 (JIS '89) : -180.00 – 650.00 Pt 100 (JIS '97, IEC) : -180.00 – 850.00 Pt 50 Ω (JIS '81) : -180.00 – 649.00 Ni 508.4 Ω : -30.00 – 200.00 Pt 1000 : -180.00 – 850.00 Ni 100 : -30.00 – 200.00 Cu 10 @ 25°C : -30.00 – 250.00	°C	100.0
	16	Ch1 Input decimal point	No decimal point The number of decimal places : 1 or 2	—	1 place of decimals
	18	Ch1 Output range	0 – 20 mA -5 – +5 V -10 – +10 V	—	0 – 20 mA
	19	Ch1 0 % output setting	0.000 – 19.000 -5.000 – 4.750 -10.000 – 9.000	mA V V	4.000
	20	Ch1 100 % output setting	1.000 – 20.000 -4.750 – 5.000 -9.000 – 10.000	mA V V	20.000
	74	Ch1 Burnout	None / Down / Up	—	Up
	75	Ch1 Sensor wires	2 Wires / 3 Wires	—	3 Wires
	76	Ch1 Wire resistance	0.000 – 50.000*	Ω	0.000
	79	Ch1 Filter time constant	0 – 30	sec.	0
	80	Ch1 Input zero fine adjust	-10.00 – 10.00*	°C	0.00
	81	Ch1 Input span fine adjust	-10.00 – 10.00*	°C	0.00
	82	Ch1 Output zero fine adjust	-5.000 – 5.000	%	0.000
	83	Ch1 Output span fine adjust	95.000 – 105.000	%	100.000
	89	Ch1 Loop test	-10.00 – 110.00	%	Cancel

MODE	ITEM	SETTING PARAMETER	RANGE	UNIT	INITIAL VALUE	
Ch2 setting	109	Ch2 Temperature unit	°C / °F / K	—	°C	
	111	Ch2 Input range	JPt 100 (JIS '89) Pt 100 (JIS '89) Pt 100 (JIS '97, IEC) Pt 50 Ω (JIS '81) Ni 508.4 Ω Pt 1000 Ni 100 Cu 10 @ 25°C	—	Pt 100 (JIS '97, IEC)	
	112	Ch2 0 % input setting	JPt 100 (JIS '89) : -200.00 – 480.00 Pt 100 (JIS '89) : -200.00 – 630.00 Pt 100 (JIS '97, IEC) : -200.00 – 830.00 Pt 50 Ω (JIS '81) : -200.00 – 629.00 Ni 508.4 Ω : -50.00 – 180.00 Pt 1000 : -200.00 – 830.00 Ni 100 : -50.00 – 180.00 Cu 10 @ 25°C : -50.00 – 230.00	°C	0.0	
	113	Ch2 100 % input setting	JPt 100 (JIS '89) : -180.00 – 500.00 Pt 100 (JIS '89) : -180.00 – 650.00 Pt 100 (JIS '97, IEC) : -180.00 – 850.00 Pt 50 Ω (JIS '81) : -180.00 – 649.00 Ni 508.4 Ω : -30.00 – 200.00 Pt 1000 : -180.00 – 850.00 Ni 100 : -30.00 – 200.00 Cu 10 @ 25°C : -30.00 – 250.00	°C	100.0	
	116	Ch2 Input decimal point	No decimal point The number of decimal places : 1 or 2	—	1 place of decimals	
	118	Ch2 Output range	0 – 20 mA -5 – +5 V -10 – +10 V	—	0 – 20 mA	
	119	Ch2 0 % output setting	0.000 – 19.000 -5.000 – 4.750 -10.000 – 9.000	mA V V	4.000	
	120	Ch2 100 % output setting	1.000 – 20.000 -4.750 – 5.000 -9.000 – 10.000	mA V V	20.000	
	174	Ch2 Burnout	None / Down / Up	—	Up	
	175	Ch2 Sensor wires	2 Wires / 3 Wires	—	3 Wires	
	176	Ch2 Wire resistance	0.000 – 50.000*	Ω	0.000	
	179	Ch2 Filter time constant	0 – 30	sec.	0	
	180	Ch2 Input zero fine adjust	-10.00 – 10.00*	°C	0.00	
	181	Ch2 Input span fine adjust	-10.00 – 10.00*	°C	0.00	
	182	Ch2 Output zero fine adjust	-5.000 – 5.000	%	0.000	
	183	Ch2 Output span fine adjust	95.000 – 105.000	%	100.000	
	189	Ch2 Loop test	-10.00 – 110.00	%	Cancel	
	01	Lockout setting	Lock / Unlock	—	Lock	
	Advanced	201	Display setting	Upper: choose from 8 types* Lower: choose from 9 types*	—	Upper: Ch1 INPUT Lower: Ch2 INPUT
		202	Channel enable	Choose from 3 types*	—	Ch1 enable Ch2 enable
203		Brightness	1 (darkest) – 4 (brightest)	—	4	
204		Display timeout	0 (always on), 1 – 60	min.	10	
205		Reset all settings	OFF / RESET	—	OFF	
206		Version indication	—	—	—	
01		Lockout setting	Lock / Unlock	—	Lock	

* For detailed types, refer to the operating manual (EM-5984-B).

EXTERNAL DIMENSIONS & TERMINAL ASSIGNMENTS unit: mm [inch]

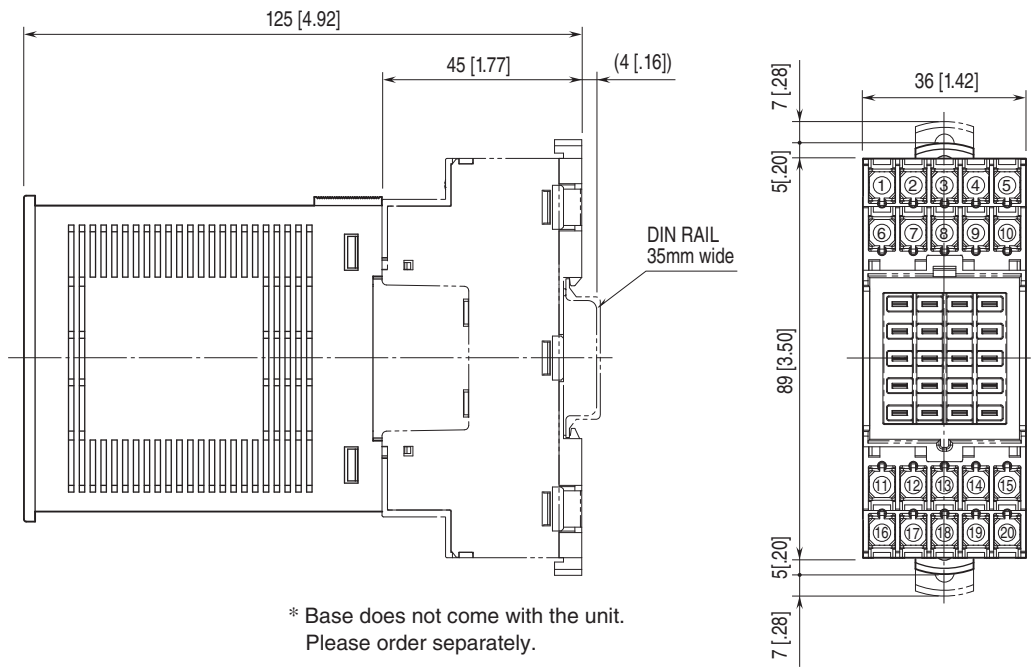

MOUNTING REQUIREMENTS unit: mm [inch]

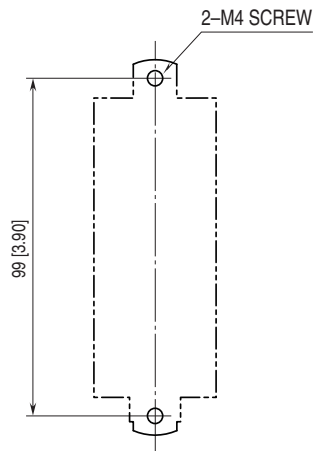

*** Mounting requirements for base.**

SCHEMATIC CIRCUITRY & CONNECTION DIAGRAM

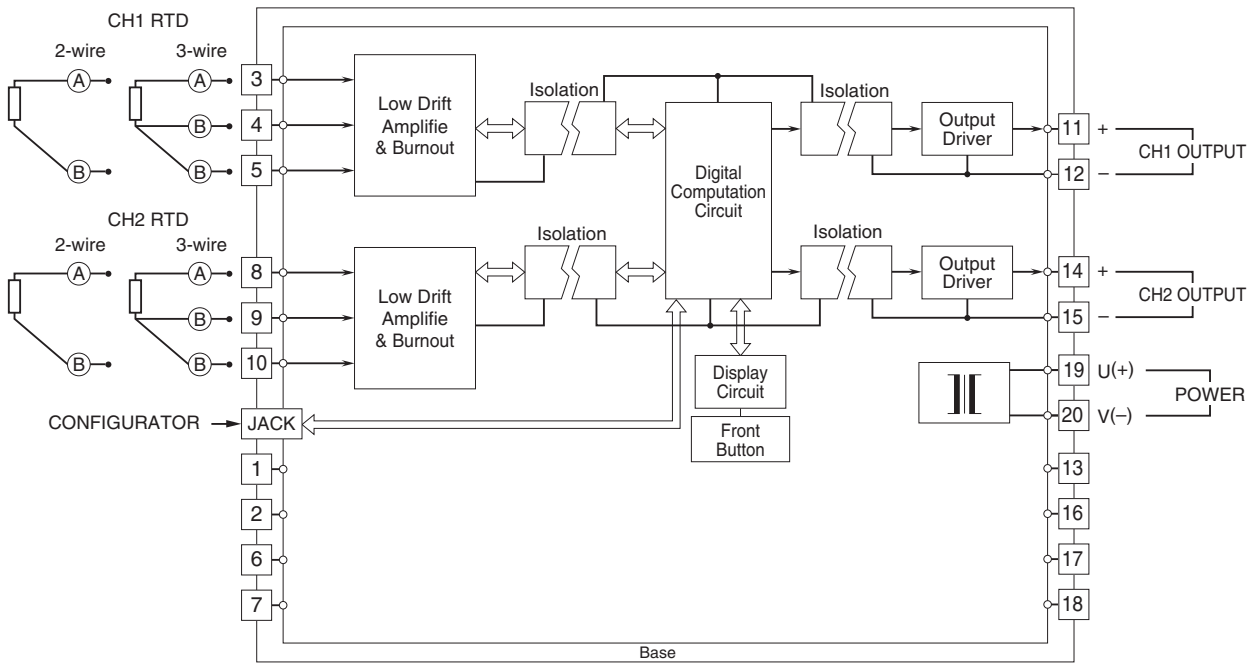

Specifications are subject to change without notice.