

2 Channel Super-mini Signal Conditioners with Display M1E-2 Series

N, U, L, P (Platinel II)

THERMOCOUPLE TRANSMITTER

(2 channels, PC programmable)

Functions & Features

- Accepts direct input from a thermocouple and provides a linearized process signal
- Wide selection of thermocouples
- 2 channels
- Adjustments with the front button
- OEL display with good visibility

Typical Applications

- Small burnout sensing current enables long distance transmission with minimum offset drifts
- Electric furnace (isolation)
- No burnout type can connect to a single T/C in parallel with a recorder

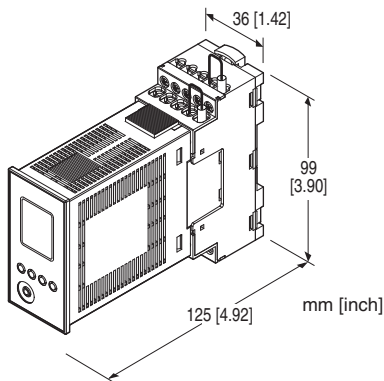

Note: The figure shows the combination of the unit and the base.

MODEL: M1EXT-2-[1][2]

ORDERING INFORMATION

- Code number: M1EXT-2-[1][2]
- Specify a code from below for each of [1] and [2].
(e.g. M1EXT-2-M2/Q)
- Specify the specification for option code /Q
(e.g. /C01/SET)

NO. OF CHANNELS

2: 2 channels

INPUT - Field-selectable

Thermocouple

(PR), K (CA), E (CRC), J (IC), T (CC), B (RH), R, S, C (WRe 5-26),

OUTPUT - Field-selectable

◆ DC Output

- Current output: 0 - 20 mA DC
- Voltage output: -5 - +5 V DC
- Voltage output: -10 - +10 V DC

[1] POWER INPUT

AC Power

M2: 100 - 240 V AC (Operational voltage range 85 - 264 V, 47 - 66 Hz)

DC Power

R: 24 V DC

(Operational voltage range 24 V ±10 %, ripple 10 %p-p max.)

P: 110 V DC

(Operational voltage range 85 - 150 V, ripple 10 %p-p max.)

[2] OPTIONS

blank: none

/Q: With options (specify the specification)

SPECIFICATIONS OF OPTION: Q (multiple selections)

COATING (For the detail, refer to our web site.)

/C01: Silicone coating

/C02: Polyurethane coating

/C03: Rubber coating

EX-FACTORY SETTING

/SET: Preset according to the Ordering Information Sheet (No. ESU-5985)

RELATED PRODUCTS

- Installation base (model: M1E-BS2)
 - PC Configurator cable (model: MCN-CON or COP-US)
 - M1E configurator software (model: M1EFCG)
- Downloadable at our web site.

GENERAL SPECIFICATIONS

Construction: Plug-in

Connection

- Connected to base with connector
- Base

M2.6 screw terminals (torque: 0.5 N·m)

Applicable solderless terminal size (M3)

Screw terminal: Nickel-plated steel

Housing material: Flame-resistant resin (black)

Isolation: Ch1 input to Ch2 input to Ch1 output to Ch2 output to power

Overrange output: Approx. -10 to +110 % (Not available for current output not greater than 0 mA)

Input zero fine adj. range: -10 to +10°C (front button)
Input span fine adj. range: -10 to +10°C (front button)
Output zero fine adj. range: -5 to +5% (front button)
Output span fine adj. range: 95 to 105% (front button)
Burnout protection: Upscale standard; downscale or no burnout optional by programming
 (Set to "None" at item [74] Burnout, when the unit is connected with another instrument in parallel.)
Cold junction compensation: CJC sensor attached to the input terminals
Configuration: Program with front buttons or Via PC.
Programmable features include: Refer to the parameter list.
Configurator connection: 2.5 dia. miniature jack;
 RS-232-C level
■Recommended solderless terminal size - M3 (unit: mm)

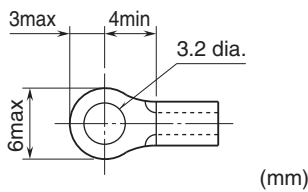

DISPLAY

Display functions: Displays and sets measured range, engineering unit
Display size: Approx. 15.6 × 20.8 mm (0.61" × 0.82")
Number of pixels: 68 × 95 (horizontal × vertical)
Character color: Yellow
Display life: Approx. 50000 hours
 (Expected time for the Display brightness to be reduced to 50 % when the Display is used continuously with brightness setting 2 in 25 °C)
Display type: OEL display
Display digit: Negative 5 digits, positive 6 digits (-99999 to 999999)
Decimal point position: None, number of decimal places 1 or 2

INPUT SPECIFICATIONS

Input resistance: 1 MΩ min.
Burnout sensing: ≤ 0.2 μA
Measurement rang: -5 to +105% of input setting value
 Refer to the operating manual (EM-5985-B) for changing input range, setting value.

OUTPUT SPECIFICATIONS

■ DC Current
Output range: 0 - 20 mA DC
Conformance range: 0 - 22mA DC
Minimum span: 1 mA

Load resistance: Output drive 15 V max.
 (e.g. 4 - 20 mA: 750 Ω [15 V ÷ 20 mA])
 (Not available to output less than 0 mA, output range may not be extended to -5 %)

■ DC Voltage

Output range: -5 - +5 V DC, -10 - +10 V DC
Conformance range: -6 - +6 V DC, -12 - +12 V DC
Minimum span: 250 mV, 1 V
Load resistance: 200 kΩ min.

INSTALLATION

Power Consumption

•AC:
 ≤ 7 VA at 100 V
 ≤ 10 VA at 200 V
 ≤ 12 VA at 264 V
•DC: ≤ 4 W

Operating temperature: -5 to +55°C (23 to 131°F)
Storage temperature: -5 to +55°C (23 to 131°F)
Operating humidity: 10 to 85 %RH (non-condensing)
Mounting: Surface or DIN rail
Weight: 120 g (0.26 lb) except base

PERFORMANCE

Accuracy: Input accuracy + output accuracy
 See CALCULATION EXAMPLES OF OVERALL ACCURACY.
 Inversely proportional to the setting span.
Input accuracy: [Table 1 Accuracy value + Cold Junction Compensation Error 0.5°C (0.9°F)]
Display accuracy:
 Input display: Input accuracy ±1 digit
 Output display: Input accuracy + output accuracy ±1 digit
Output accuracy: (% of max. output range)
 0 - 20 mA: ±0.06 %
 -5 - +5 V: ±0.03 %
 -10 - +10 V: ±0.03 %
Cold junction compensation error:
 ±0.5°C at 25 ±10°C
 ±0.9°F at 77 ±18°F
 (The described accuracy may be partially not satisfied when the input temperature is below 0°C. Consult factory.)
Temp. coefficient (% of max. I/O range): ±0.015 %/°C
 (±0.008 %/°F)
Response time (filter time constant: 0 sec.): ≤ 0.5 sec.
 (0 - 90 %)
Burnout response: ≤ 10 sec.
Line voltage effect: ±0.1 % over voltage range
Insulation resistance: ≥ 100 MΩ with 500 V DC
Dielectric strength: 1500 V AC @ 1 minute
 (Ch1 input to Ch2 input to Ch1 output to Ch2 output to

power to ground)

CALCULATION EXAMPLES OF OVERALL ACCURACY

[Example] Input Range K thermocouple, 0 - 1000°C, Output Range 0 - 20 mA, Output Setting 4 - 20 mA

■ Overall accuracy

• Input Accuracy

1) Absolute value accuracy (Table 1): 1.00°C

2) CJC error (0.5°C) added: 1.50°C

3) $1.50^{\circ}\text{C} \div 1000^{\circ}\text{C} \times 100 = 0.15 \%$

• Output Accuracy = Output Range Span (20 mA) \div Output Span Setting (16 mA) \times 0.06 % = 0.075 %

Overall Accuracy = 0.15 + 0.075 = \pm (0.225 % of span)

[Table 1]

INPUT RANGE	°C			
	MINIMUM SPAN	SETTING RANGE	ACCURACY	CONFORMANCE RANGE
(PR)	20	0 to 1760	\pm 2.00	0 to 1760
K (CA)	20	-270 to +1370	\pm 1.00	-150 to +1370
E (CRC)	20	-270 to +1000	\pm 1.00	-170 to +1000
J (IC)	20	-210 to +1200	\pm 1.00	-180 to +1200
T (CC)	20	-270 to +400	\pm 1.00	-170 to +400
B (RH)	20	0 to 1820	\pm 2.00	400 to 1760
R	20	-50 to +1760	\pm 2.00	200 to 1760
S	20	-50 to +1760	\pm 2.00	0 to 1760
C (WRe 5-26)	20	0 to 2315	\pm 2.00	0 to 2315
N	20	-270 to +1300	\pm 1.00	-130 to +1300
U	20	-200 to +600	\pm 1.00	-200 to +600
L	20	-200 to +900	\pm 1.00	-200 to +900
P (Platinel II)	20	0 to 1395	\pm 1.00	0 to 1395
INPUT RANGE	°F			
	MINIMUM SPAN	SETTING RANGE	ACCURACY	CONFORMANCE RANGE
(PR)	36	32 to 3200	\pm 3.60	32 to 3200
K (CA)	36	-454 to +2498	\pm 1.80	-238 to +2498
E (CRC)	36	-454 to +1832	\pm 1.80	-274 to +1832
J (IC)	36	-346 to +2192	\pm 1.80	-292 to +2192
T (CC)	36	-454 to +752	\pm 1.80	-274 to +752
B (RH)	36	32 to 3308	\pm 3.60	752 to 3200
R	36	-58 to +3200	\pm 3.60	392 to 3200
S	36	-58 to +3200	\pm 3.60	32 to 3200
C (WRe 5-26)	36	32 to 4199	\pm 3.60	32 to 4199
N	36	-454 to +2372	\pm 1.80	-202 to +2372
U	36	-328 to +1112	\pm 1.80	-328 to +1112
L	36	-328 to +1652	\pm 1.80	-328 to +1652
P (Platinel II)	36	32 to 2543	\pm 1.80	32 to 2543
INPUT RANGE	K			
	MINIMUM SPAN	SETTING RANGE	ACCURACY	CONFORMANCE RANGE
(PR)	20	273.15 to 2033.15	\pm 2.00	273.15 to 2033.15
K (CA)	20	3.15 to 1643.15	\pm 1.00	123.15 to 1643.15
E (CRC)	20	3.15 to 1273.15	\pm 1.00	103.15 to 1273.15
J (IC)	20	63.15 to 1473.15	\pm 1.00	93.15 to 1473.15
T (CC)	20	3.15 to 673.15	\pm 1.00	103.15 to 673.15
B (RH)	20	273.15 to 2093.15	\pm 2.00	673.15 to 2033.15
R	20	223.15 to 2033.15	\pm 2.00	473.15 to 2033.15
S	20	223.15 to 2033.15	\pm 2.00	273.15 to 2033.15
C (WRe 5-26)	20	273.15 to 2588.15	\pm 2.00	273.15 to 2588.15
N	20	3.15 to 1573.15	\pm 1.00	143.15 to 1573.15
U	20	73.15 to 873.15	\pm 1.00	73.15 to 873.15
L	20	73.15 to 1173.15	\pm 1.00	73.15 to 1173.15
P (Platinel II)	20	273.15 to 1668.15	\pm 1.00	273.15 to 1668.15

STANDARDS & APPROVALS

EU conformity:

EMC Directive

EMI EN 61000-6-4

EMS EN 61000-6-2

Low Voltage Directive

EN 61010-1

Installation Category II

Pollution Degree 2

Input or output to power: Reinforced insulation (300 V)

RoHS Directive

EXTERNAL VIEW

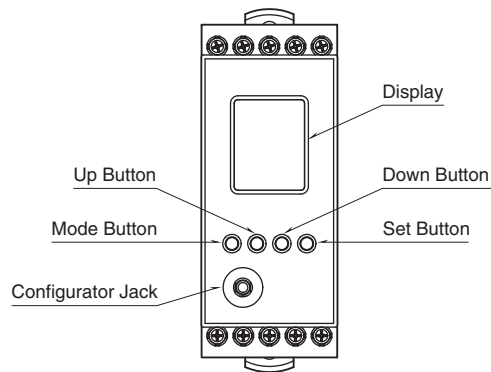

COMPONENT	FUNCTION
Display	Indicates present values, setting values and abnormal information. Two types of present values are displayed respectively at the upper and lower parts according to setting.
Mode button	Shifts from Measuring mode to each setting mode. The destination changes depending on how long the button is held down. Pressing Mode button for ≥ 2 seconds returns to Measuring mode from each setting mode.
Set button	Shifts the setting value of each setting parameter item to a setting changeable state. When at setting changeable state, used to move through the digits of setting value and to enter (save) the setting value.
Up button	Shifts through setting parameter items and to increase or select the setting value.
Down button	Shifts through setting parameter items and to decrease or select the setting value.
Configurator Jack	Used to perform configuration with M1E configurator software (model: M1ECFG). When using the software, set the Lockout setting of the unit to 'Lock'.

Refer to the operating manual (EM-5985-B) for detailed procedures.

TERMINAL ASSIGNMENTS

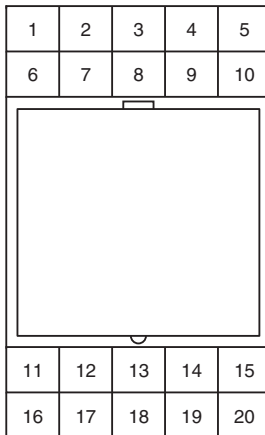

No.	FUNCTION	No.	FUNCTION
1	Unused	11	Ch1 Output +
2	Unused	12	Ch1 Output -
3	Ch1 T/C +	13	Unused
4	Ch1 COM	14	Ch2 Output +
5	Ch1 CJC Sensor	15	Ch2 Output -
6	Unused	16	Unused
7	Unused	17	Unused
8	Ch2 T/C +	18	Unused
9	Ch2 COM	19	Power U (+)
10	Ch2 CJC Sensor	20	Power V (-)

*** Base does not come with the unit. Please order separately.**

PARAMETER LIST

It is available to configure or confirm settings shown below by using front button. Configuring or confirming with PC is available when using M1E configurator software (model: M1ECFG).

MODE	ITEM	SETTING PARAMETER	RANGE	UNIT	INITIAL VALUE
Ch1 setting	01	Lockout setting	Lock / Unlock	—	Lock
	09	Ch1 Temperature unit	°C / °F / K	—	°C
	11	Ch1 Input range	(PR) K (CA) E (CRC) J (IC) T (CC) B (RH) R S C (WRe 5-26) N U L P (Platinel II)	—	K (CA)
	12	Ch1 0 % input setting	(PR) : 0.0 – 1740.0 K (CA) : -270.0 – 1350.0 E (CRC) : -270.0 – 980.0 J (IC) : -210.0 – 1180.0 T (CC) : -270.0 – 380.0 B (RH) : 0.0 – 1800.0 R : -50.0 – 1740.0 S : -50.0 – 1740.0 C (WRe 5-26) : 0.0 – 2295.0 N : -270.0 – 1280.0 U : -200.0 – 580.0 L : -200.0 – 880.0 P (Platinel II) : 0.0 – 1375.0	°C	0.0
	13	Ch1 100 % input setting	(PR) : 20.0 – 1760.0 K (CA) : -250.0 – 1370.0 E (CRC) : -250.0 – 1000.0 J (IC) : -190.0 – 1200.0 T (CC) : -250.0 – 400.0 B (RH) : 20.0 – 1820.0 R : -30.0 – 1760.0 S : -30.0 – 1760.0 C (WRe 5-26) : 20.0 – 2315.0 N : -250.0 – 1300.0 U : -180.0 – 600.0 L : -180.0 – 900.0 P (Platinel II) : 20.0 – 1395.0	°C	1000.0
	16	Ch1 Input decimal point	No decimal point The number of decimal places : 1 or 2	—	1 place of decimals
	18	Ch1 Output range	0 – 20 mA -5 – +5 V -10 – +10 V	—	0 – 20 mA
	19	Ch1 0 % output setting	0.000 – 19.000 -5.000 – 4.750 -10.000 – 9.000	mA V V	4.000
	20	Ch1 100 % output setting	1.000 – 20.000 -4.750 – 5.000 -9.000 – 10.000	mA V V	20.000
	74	Ch1 Burnout	None / Down / Up	—	Up
	77	Ch1 Cold junction compensation	CJM / FXD TEMP	—	CJM
	78	Ch1 Preset fixed terminal temperature	-50.00 – 100.00*	°C	0.00
	79	Ch1 Filter time constant	0 – 30	sec.	0
	80	Ch1 Input zero fine adjust	-10.00 – 10.00*	°C	0.00
	81	Ch1 Input span fine adjust	-10.00 – 10.00*	°C	0.00
	82	Ch1 Output zero fine adjust	-5.000 – 5.000	%	0.000
83	Ch1 Output span fine adjust	95.000 – 105.000	%	100.000	
89	Ch1 Loop test	-10.00 – 110.00	%	Cancel	

MODE	ITEM	SETTING PARAMETER	RANGE	UNIT	INITIAL VALUE
Ch2 setting	109	Ch2 Temperature unit	°C / °F / K	—	°C
	111	Ch2 Input range	(PR) K (CA) E (CRC) J (IC) T (CC) B (RH) R S C (WRe 5-26) N U L P (Platinel II)	—	K (CA)
	112	Ch2 0 % input setting	(PR) : 0.0 – 1740.0 K (CA) : -270.0 – 1350.0 E (CRC) : -270.0 – 980.0 J (IC) : -210.0 – 1180.0 T (CC) : -270.0 – 380.0 B (RH) : 0.0 – 1800.0 R : -50.0 – 1740.0 S : -50.0 – 1740.0 C (WRe 5-26) : 0.0 – 2295.0 N : -270.0 – 1280.0 U : -200.0 – 580.0 L : -200.0 – 880.0 P (Platinel II) : 0.0 – 1375.0	°C	0.0
	113	Ch2 100 % input setting	(PR) : 20.0 – 1760.0 K (CA) : -250.0 – 1370.0 E (CRC) : -250.0 – 1000.0 J (IC) : -190.0 – 1200.0 T (CC) : -250.0 – 400.0 B (RH) : 20.0 – 1820.0 R : -30.0 – 1760.0 S : -30.0 – 1760.0 C (WRe 5-26) : 20.0 – 2315.0 N : -250.0 – 1300.0 U : -180.0 – 600.0 L : -180.0 – 900.0 P (Platinel II) : 20.0 – 1395.0	°C	1000.0
	116	Ch2 Input decimal point	No decimal point The number of decimal places : 1 or 2	—	1 place of decimals
	118	Ch2 Output range	0 – 20 mA -5 – +5 V -10 – +10 V	—	0 – 20 mA
	119	Ch2 0 % output setting	0.000 – 19.000 -5.000 – 4.750 -10.000 – 9.000	mA V V	4.000
	120	Ch2 100 % output setting	1.000 – 20.000 -4.750 – 5.000 -9.000 – 10.000	mA V V	20.000
	174	Ch2 Burnout	None / Down / Up	—	Up
	177	Ch2 Cold junction compensation	CJM / FXD TEMP	—	CJM
	178	Ch2 Preset fixed terminal temperature	-50.00 – 100.00*	°C	0.00
	179	Ch2 Filter time constant	0 – 30	sec.	0
	180	Ch2 Input zero fine adjust	-10.00 – 10.00*	°C	0.00
	181	Ch2 Input span fine adjust	-10.00 – 10.00*	°C	0.00
	182	Ch2 Output zero fine adjust	-5.000 – 5.000	%	0.000
	183	Ch2 Output span fine adjust	95.000 – 105.000	%	100.000
	189	Ch2 Loop test	-10.00 – 110.00	%	Cancel
01	Lockout setting	Lock / Unlock	—	Lock	
Advanced	201	Display setting	Upper: choose from 8 types* Lower: choose from 9 types*	—	Upper: Ch1 INPUT Lower: Ch2 INPUT
	202	Channel enable	Choose from 3 types*	—	Ch1 enable Ch2 enable
	203	Brightness	1 (darkest) – 4 (brightest)	—	4
	204	Display timeout	0 (always on), 1 – 60	min.	10
	205	Reset all settings	OFF / RESET	—	OFF
	206	Version indication	—	—	—
	01	Lockout setting	Lock / Unlock	—	Lock

* For detailed types, refer to the operating manual (EM-5985-B).

EXTERNAL DIMENSIONS unit: mm [inch]

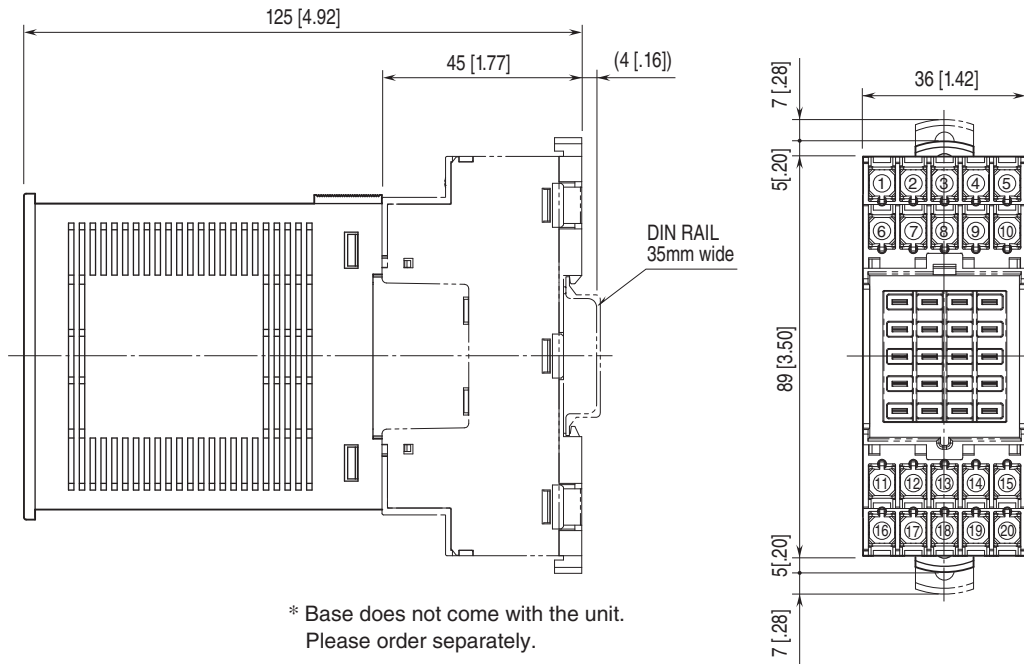

MOUNTING REQUIREMENTS unit: mm [inch]

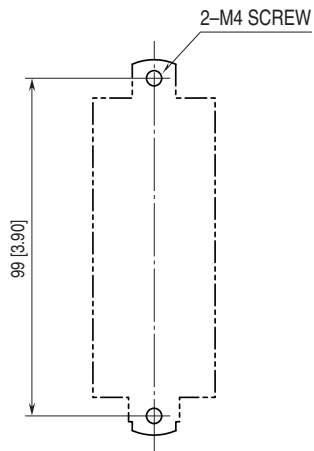

* Mounting requirements for base.

TERMINAL ASSIGNMENTS

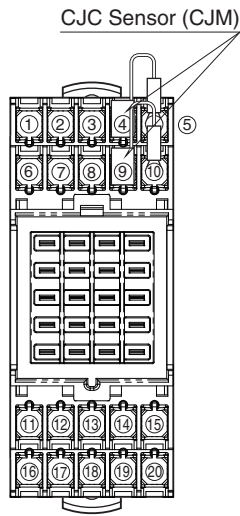

* Base does not come with the unit. Please order separately.

SCHEMATIC CIRCUITRY & CONNECTION DIAGRAM

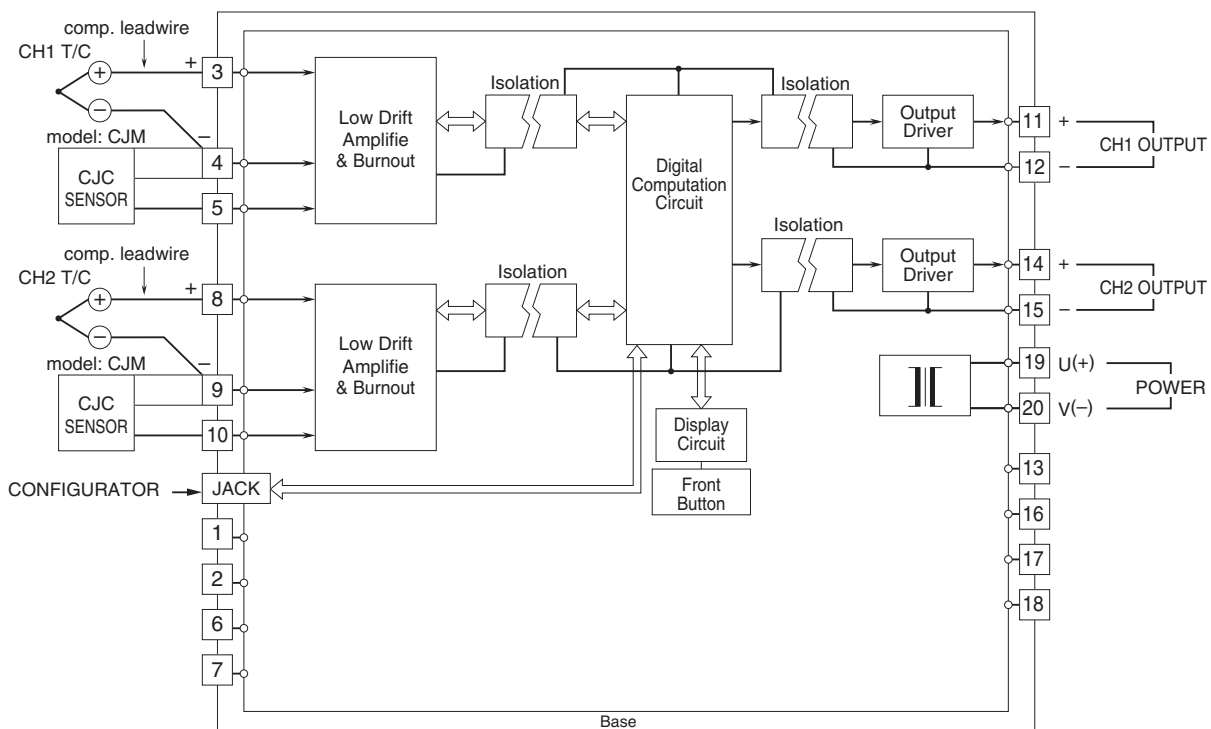

Specifications are subject to change without notice.