

## Super-mini Signal Conditioners Mini-M Series

### RAMP BUFFER

#### Functions & Features

- Limiting the rate of change of the output once the rate of the input exceeds the preset value
- Rate-of-change adjustable up to 40 seconds

#### Typical Applications

- Reducing the rate of change caused by a step change or spikes on the input signal
- Protecting equipment that cannot withstand rapidly changing process variables

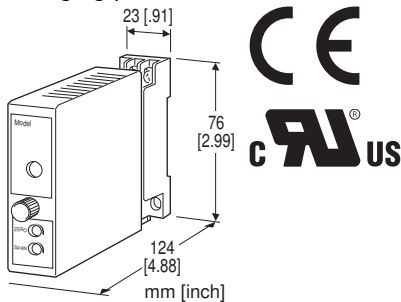

### MODEL: M2CRS-[1][2]-[3][4]

#### ORDERING INFORMATION

- Code number: M2CRS-[1][2]-[3][4]
- Specify a code from below for each of [1] through [4].  
(e.g. M2CRS-6A-M2/CE/Q)
- Special input and output ranges (For codes Z & O)
  - Specify the specification for option code /Q  
(e.g. /C01/S01)

#### [1] INPUT

##### Current

- A: 4 - 20 mA DC (Input resistance 250 Ω)
- A1: 4 - 20 mA DC (Input resistance 50 Ω)
- B: 2 - 10 mA DC (Input resistance 500 Ω)
- C: 1 - 5 mA DC (Input resistance 1000 Ω)
- D: 0 - 20 mA DC (Input resistance 50 Ω)
- E: 0 - 16 mA DC (Input resistance 62.5 Ω)
- F: 0 - 10 mA DC (Input resistance 100 Ω)
- G: 0 - 1 mA DC (Input resistance 1000 Ω)
- H: 10 - 50 mA DC (Input resistance 100 Ω)
- J: 0 - 10 μA DC (Input resistance 1000 Ω)
- K: 0 - 100 μA DC (Input resistance 1000 Ω)
- GW: -1 - +1 mA DC (Input resistance 1000 Ω)
- FW: -10 - +10 mA DC (Input resistance 100 Ω)
- Z: Specify current (See INPUT SPECIFICATIONS)

##### Voltage

- 1: 0 - 10 mV DC (Input resistance 10 kΩ min.)
- 15: 0 - 50 mV DC (Input resistance 10 kΩ min.)
- 16: 0 - 60 mV DC (Input resistance 10 kΩ min.)
- 2: 0 - 100 mV DC (Input resistance 100 kΩ min.)
- 3: 0 - 1 V DC (Input resistance 1 MΩ min.)
- 4: 0 - 10 V DC (Input resistance 1 MΩ min.)
- 5: 0 - 5 V DC (Input resistance 1 MΩ min.)
- 6: 1 - 5 V DC (Input resistance 1 MΩ min.)
- 4W: -10 - +10 V DC (Input resistance 1 MΩ min.)
- 5W: -5 - +5 V DC (Input resistance 1 MΩ min.)
- 0: Specify voltage (See INPUT SPECIFICATIONS)

#### [2] OUTPUT

##### Current

- A: 4 - 20 mA DC (Load resistance 750 Ω max.)
- B: 2 - 10 mA DC (Load resistance 1500 Ω max.)
- C: 1 - 5 mA DC (Load resistance 3000 Ω max.)
- D: 0 - 20 mA DC (Load resistance 750 Ω max.)
- E: 0 - 16 mA DC (Load resistance 900 Ω max.)
- F: 0 - 10 mA DC (Load resistance 1500 Ω max.)
- G: 0 - 1 mA DC (Load resistance 15 kΩ max.)
- Z: Specify current (See OUTPUT SPECIFICATIONS)

##### Voltage

- 1: 0 - 10 mV DC (Load resistance 10 kΩ min.)
- 2: 0 - 100 mV DC (Load resistance 100 kΩ min.)
- 3: 0 - 1 V DC (Load resistance 1000 Ω min.)
- 4: 0 - 10 V DC (Load resistance 10 kΩ min.)
- 5: 0 - 5 V DC (Load resistance 5000 Ω min.)
- 6: 1 - 5 V DC (Load resistance 5000 Ω min.)
- 4W: -10 - +10 V DC (Load resistance 10 kΩ min.)
- 5W: -5 - +5 V DC (Load resistance 5000 Ω min.)
- 0: Specify voltage (See OUTPUT SPECIFICATIONS)

#### [3] POWER INPUT

##### AC Power

- M: 85 - 264 V AC (Operational voltage range 85 - 264 V, 47 - 66 Hz)  
(Select '/N' for 'Standards & Approvals' code.)
- M2: 100 - 240 V AC (Operational voltage range 85 - 264 V, 47 - 66 Hz)  
(90 - 264 V for UL)

##### DC Power

- R: 24 V DC  
(Operational voltage range 24 V ±10 %, ripple 10 %p-p max.)
- R2: 11 - 27 V DC  
(Operational voltage range 11 - 27 V, ripple 10 %p-p max.)  
(Select '/N' for 'Standards & Approvals' code.)
- P: 110 V DC  
(Operational voltage range 85 - 150 V, ripple 10 %p-p max.)  
(110 V ±10 % for UL)

## [4] OPTIONS (multiple selections)

### Standards & Approvals (must be specified)

/N: Without CE or UL

/CE: CE marking

/UL: UL approval, CE marking

### Other Options

blank: none

/Q: Option other than the above (specify the specification)

### SPECIFICATIONS OF OPTION: Q (multiple selections)

#### COATING (For the detail, refer to our web site.)

/C01: Silicone coating

/C02: Polyurethane coating

/C03: Rubber coating (UL not available)

/C04: Polyolefin coating (UL not available)

#### TERMINAL SCREW MATERIAL

/S01: Stainless steel (UL not available)

## GENERAL SPECIFICATIONS

**Construction:** Plug-in

**Connection:** M3 screw terminals (torque 0.8 N·m)

**Screw terminal:** Chromated steel (standard) or stainless steel

**Housing material:** Flame-resistant resin (black)

**Isolation:** Input to output to power

**Overrange output:** Approx. -10 to +120 % at 1 - 5 V

**Rate-of-change adjustment:** 260°-turn screwdriver adjustment (front)

**Rate-of-change adjustment range:** Approx. 0.5 to 40 sec. (0 - 100 %; factory set to MIN.)

**Zero adjustment:** -5 to +5 % (front)

**Span adjustment:** 95 to 105 % (front)

## INPUT SPECIFICATIONS

### DC Current:

Shunt resistor attached to the input terminals (0.5 W)

Specify input resistance value for code Z.

■ **DC Voltage:** -300 - +300 V DC

**Minimum span:** 3 mV

**Offset:** Max. 1.5 times span

### Input resistance

Span 3 - 10 mV :  $\geq 10 \text{ k}\Omega$

Span 10 - 100 mV :  $\geq 10 \text{ k}\Omega$

Span 0.1 - 1 V :  $\geq 100 \text{ k}\Omega$

Span  $\geq 1 \text{ V}$  :  $\geq 1 \text{ M}\Omega$

## OUTPUT SPECIFICATIONS

■ **DC Current:** 0 - 20 mA DC

**Minimum span:** 1 mA

**Offset:** Max. 1.5 times span

**Load resistance:** Output drive 15 V max.

■ **DC Voltage:** -10 - +12 V DC

**Minimum span:** 5 mV

**Offset:** Max. 1.5 times span

**Load resistance:** Output drive 1 mA max.; at  $\geq 0.5 \text{ V}$

## INSTALLATION

### Power Consumption

#### •AC:

Approx. 3 VA at 100 V

Approx. 4 VA at 200 V

Approx. 5 VA at 264 V

#### •DC: Approx. 3 W

**Operating temperature:** -5 to +55°C (23 to 131°F)

**Operating humidity:** 30 to 90 %RH (non-condensing)

**Mounting:** Surface or DIN rail

**Weight:** 150 g (0.33 lb)

## PERFORMANCE in percentage of span

**Accuracy:**  $\pm 0.2 \%$

**Temp. coefficient:**  $\pm 0.015 \%/^{\circ}\text{C}$  ( $\pm 0.008 \%/^{\circ}\text{F}$ )

**Line voltage effect:**  $\pm 0.1 \%$  over voltage range

**Insulation resistance:**  $\geq 100 \text{ M}\Omega$  with 500 V DC

**Dielectric strength:** 2000 V AC @1 minute (input to output to power to ground)

## STANDARDS & APPROVALS

### EU conformity:

EMC Directive

EMI EN 61000-6-4

EMS EN 61000-6-2

Low Voltage Directive

EN 61010-1

Measurement Category II (input)

Installation Category II (power)

Pollution Degree 2

Input or output to power: Reinforced insulation (300 V)

Input to output: Basic insulation (300 V)

RoHS Directive

### Approval:

UL/C-UL nonincendive Class I, Division 2,

Groups A, B, C, and D

(UL 121201, CAN/CSA-C22.2 No.213-17)

UL/C-UL general safety requirements

(UL 61010-1, CAN/CSA-C22.2 No.61010-1-12)

## EXTERNAL VIEW

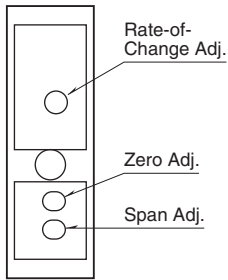

## EXTERNAL DIMENSIONS unit: mm [inch]

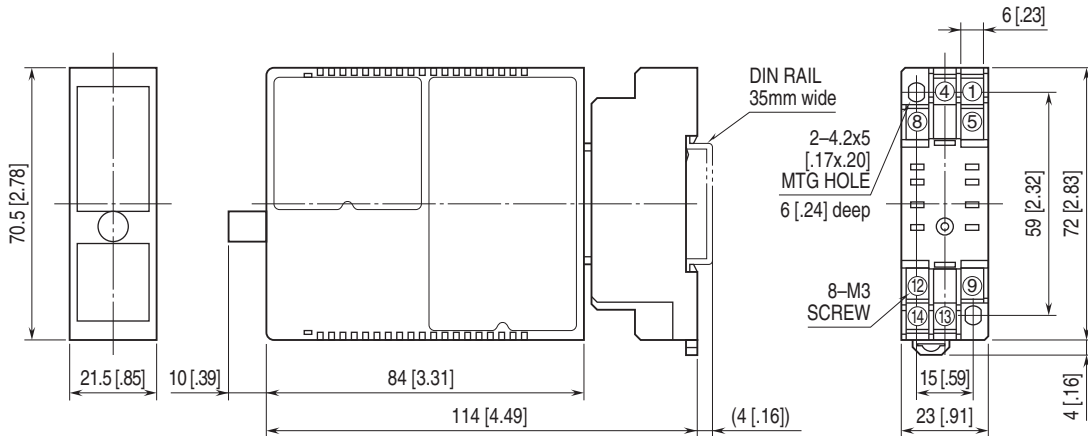

• When mounting, no extra space is needed between units.

## TERMINAL ASSIGNMENTS unit: mm [inch]

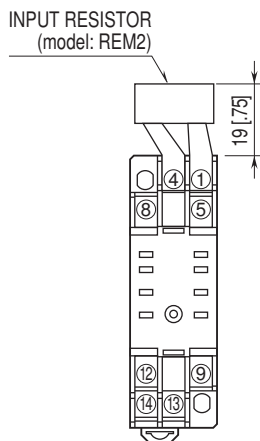

Input shunt resistor attached for current input.

**SCHEMATIC CIRCUITRY & CONNECTION DIAGRAM**

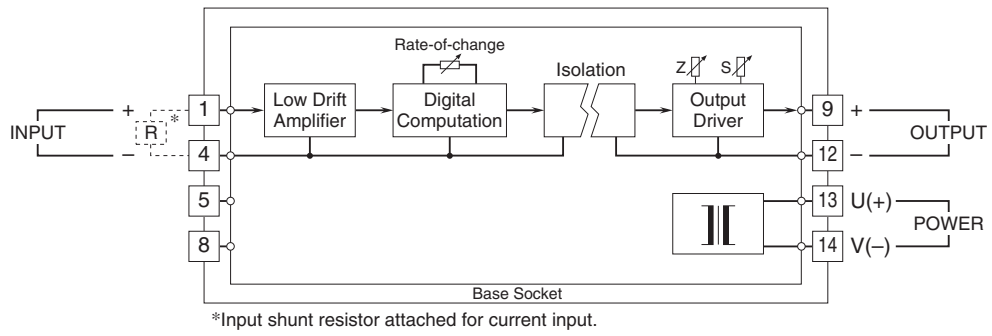

Specifications are subject to change without notice.