

Super-mini Signal Conditioners Mini-M Series

P/I TRANSDUCER

Functions & Features

- Converts a standard pneumatic signal into a proportional DC output

Typical Applications

- Converting a pneumatic system into a 4 – 20 mA for indicating and controlling in DCS system

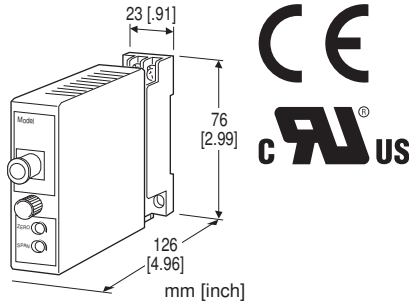

MODEL: M2PV-C[1][2]-[3][4]

ORDERING INFORMATION

- Code number: M2PV-C[1][2]-[3][4]
- Specify a code from below for each of [1] through [4]. (e.g. M2PV-C2SA-M2/CE/Q)
- Special output range (For codes Z & 0)
- Specify the specification for option code /Q (e.g. /C01/S01)

PNEUMATIC CONNECTION

C: 6 mm dia. (.24")

[1] INPUT

- 1S: 19.6 – 98.1 kPa
 2S: 20 – 100 kPa
 3S: 20.7 – 103.4 kPa
 1: 0.2 – 1.0 kgf/cm²
 2: 0.2 – 1.0 bar
 3: 3 – 15 psig

[2] OUTPUT

Current

- A: 4 – 20 mA DC (Load resistance 750 Ω max.)
 B: 2 – 10 mA DC (Load resistance 1500 Ω max.)
 C: 1 – 5 mA DC (Load resistance 3000 Ω max.)
 D: 0 – 20 mA DC (Load resistance 750 Ω max.)
 E: 0 – 16 mA DC (Load resistance 900 Ω max.)

- F: 0 – 10 mA DC (Load resistance 1500 Ω max.)
 G: 0 – 1 mA DC (Load resistance 15 kΩ max.)
 Z: Specify current (See OUTPUT SPECIFICATIONS)

Voltage

- 1: 0 – 10 mV DC (Load resistance 10 kΩ min.)
 2: 0 – 100 mV DC (Load resistance 100 kΩ min.)
 3: 0 – 1 V DC (Load resistance 1000 Ω min.)
 4: 0 – 10 V DC (Load resistance 10 kΩ min.)
 5: 0 – 5 V DC (Load resistance 5000 Ω min.)
 6: 1 – 5 V DC (Load resistance 5000 Ω min.)
 0: Specify voltage (See OUTPUT SPECIFICATIONS)

[3] POWER INPUT

AC Power

- M: 85 – 264 V AC (Operational voltage range 85 – 264 V, 47 – 66 Hz)
 (Select 'N' for 'Standards & Approvals' code.)
 M2: 100 – 240 V AC (Operational voltage range 85 – 264 V, 47 – 66 Hz)
 (90 – 264 V for UL)

DC Power

- R: 24 V DC
 (Operational voltage range 24 V ±10 %, ripple 10 %p-p max.)
 R2: 11 – 27 V DC
 (Operational voltage range 11 – 27 V, ripple 10 %p-p max.)
 (Select 'N' for 'Standards & Approvals' code.)
 P: 110 V DC
 (Operational voltage range 85 – 150 V, ripple 10 %p-p max.)
 (110 V ±10 % for UL)

[4] OPTIONS (multiple selections)

Standards & Approvals (must be specified)

- /N: Without CE or UL
 /CE: CE marking
 /UL: UL approval, CE marking

Other Options

- blank: none
 /Q: Option other than the above (specify the specification)

SPECIFICATIONS OF OPTION: Q (multiple selections)

COATING (For the detail, refer to our web site.)

- /C01: Silicone coating
 /C02: Polyurethane coating
 /C03: Rubber coating (UL not available)
 /C04: Polyolefin coating (UL not available)

TERMINAL SCREW MATERIAL

- /S01: Stainless steel (UL not available)

GENERAL SPECIFICATIONS

Construction: Plug-in

Connection

Output & power input: M3 screw terminals (torque 0.8 N·m)

Pneumatic: 6 mm dia (.24") tube

Screw terminal: Chromated steel (standard) or stainless steel

Housing material: Flame-resistant resin (black)

Isolation: Output to power

Overrange output: Approx. -10 to +120 % at 1 - 5 V

Zero adjustment: -5 to +5 % (front)

Span adjustment: 95 to 105 % (front)

INPUT SPECIFICATIONS

■ Input

19.6 - 98.1 kPa, 0.2 - 1.0 kgf/cm²

20 - 100 kPa, 0.2 - 1.0 bar

20.7 - 103.4 kPa, 3 - 15 psig

OUTPUT SPECIFICATIONS

■ **DC Current:** 0 - 20 mA DC

Minimum span: 1 mA

Offset: Max. 1.5 times span

Load resistance: Output drive 15 V max.

■ **DC Voltage:** 0 - 12 V DC

Minimum span: 5 mV

Offset: Max. 1.5 times span

Load resistance: Output drive 1 mA max.; at ≥ 1 V

INSTALLATION

Power Consumption

•AC:

Approx. 3 VA at 100 V

Approx. 4 VA at 200 V

Approx. 5 VA at 264 V

•DC: Approx. 3 W

Operating temperature: -5 to +55°C (23 to 131°F)

Operating humidity: 30 to 90 %RH (non-condensing)

Mounting: Surface or DIN rail

Weight: 150 g (0.33 lb)

PERFORMANCE in percentage of span

Accuracy: ± 0.3 %

Temp. coefficient: ± 0.03 %/°C (± 0.02 %/°F)

Response time: ≤ 0.5 sec. (0 - 90 %)

Permissible overrange: 196 kPa (2.0 kgf/cm², 1.96 bar, 28 psig)

Line voltage effect: ± 0.1 % over voltage range

Insulation resistance: ≥ 100 M Ω with 500 V DC

Dielectric strength: 2000 V AC @ 1 minute (output to power to ground)

STANDARDS & APPROVALS

EU conformity:

EMC Directive

EMI EN 61000-6-4

EMS EN 61000-6-2

Low Voltage Directive

EN 61010-1

Installation Category II

Pollution Degree 2

Output to power: Reinforced insulation (300 V)

RoHS Directive

Approval:

UL/C-UL nonincendive Class I, Division 2,

Groups A, B, C, and D

(UL 121201, CAN/CSA-C22.2 No.213-17)

UL/C-UL general safety requirements

(UL 61010-1, CAN/CSA-C22.2 No.61010-1-12)

EXTERNAL DIMENSIONS & TERMINAL ASSIGNMENTS unit: mm [inch]

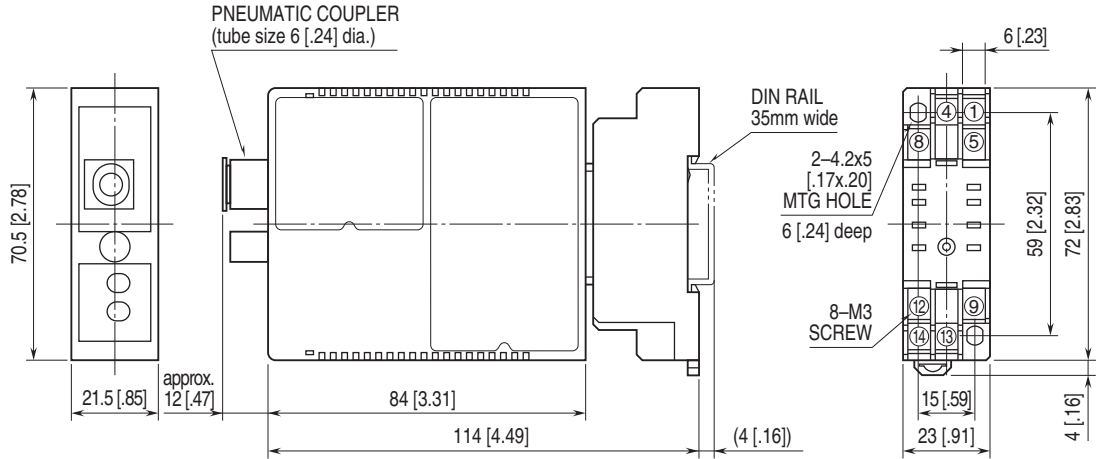

• When mounting, no extra space is needed between units.

SCHEMATIC CIRCUITRY & CONNECTION DIAGRAM

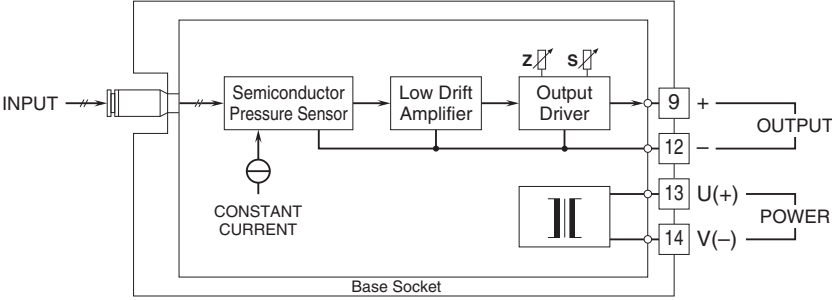

 Specifications are subject to change without notice.