

## Super-mini Terminal Block Signal Conditioners M5-UNIT

### THERMOCOUPLE TRANSMITTER

#### Functions & Features

- Accepts direct input from a thermocouple and provides a standard process signal
- Linearization and burnout
- Cold junction compensation
- Fast response type available
- High-density mounting
- Power LED

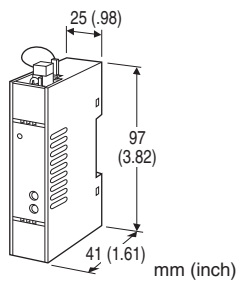

### MODEL: M5TS-[1][2]-[3][4]

#### ORDERING INFORMATION

- Code number: M5TS-[1][2]-[3][4]
- Specify a code from below for each of [1] through [4].  
(e.g. M5TS-2A-R/K/BL/Q)
- Temperature range (e.g. 0 - 800°C)
  - Special output range (For codes Z, 0 & 01)
  - Specify the specification for option code /Q  
(e.g. /C01/V01/S01)

#### [1] INPUT THERMOCOUPLE

- 1: (PR) (Usable Range 0 to 1760°C, 32 to 3200°F)
- 2: K (CA) (Usable range -270 to +1370°C, -454 to +2498°F)
- 3: E (CRC) (Usable range -270 to +1000°C, -454 to +1832°F)
- 4: J (IC) (Usable range -210 to +1200°C, -346 to +2192°F)
- 5: T (CC) (Usable range -270 to +400°C, -454 to +752°F)
- 6: B (RH) (Usable range 0 to 1820°C, 32 to 3308°F)
- 7: R (Usable range -50 to +1760°C, -58 to +3200°F)
- 8: S (Usable range -50 to +1760°C, -58 to +3200°F)
- N: N (Usable range -270 to +1300°C, -454 to +2372°F)
- 0: Specify

#### [2] OUTPUT

- Current
- A: 4 - 20 mA DC (Load resistance 550 Ω max.)
  - D: 0 - 20 mA DC (Load resistance 550 Ω max.)
  - Z: Specify current (See OUTPUT SPECIFICATIONS)
- Voltage

- 1: 0 - 10 mV DC (Load resistance 100 kΩ min.)  
(CE or UKCA not available)
- 2: 0 - 100 mV DC (Load resistance 100 kΩ min.)  
(CE or UKCA not available)
- 3: 0 - 1 V DC (Load resistance 100 Ω min.)
- 4: 0 - 10 V DC (Load resistance 1000 Ω min.)
- 5: 0 - 5 V DC (Load resistance 500 Ω min.)
- 6: 1 - 5 V DC (Load resistance 500 Ω min.)
- 1W: -10 - +10 mV DC (Load resistance 100 kΩ min.)  
(CE or UKCA not available)
- 2W: -100 - +100 mV DC (Load resistance 100 kΩ min.)  
(CE or UKCA not available)
- 3W: -1 - +1 V DC (Load resistance 800 Ω min.)
- 4W: -10 - +10 V DC (Load resistance 8000 Ω min.)
- 5W: -5 - +5 V DC (Load resistance 4000 Ω min.)
- 0: Specify voltage (See OUTPUT SPECIFICATIONS)
- 01: Specify voltage (See OUTPUT SPECIFICATIONS)  
(CE or UKCA not available)

#### [3] POWER INPUT

- AC Power
- M: 85 - 264 V AC (Operational voltage range 85 - 264 V, 47 - 66 Hz)  
(CE or UKCA not available)
- DC Power
- R: 24 V DC  
(Operational voltage range 24 V ±10 %, ripple 10 %p-p max.)

#### [4] OPTIONS (multiple selections)

- Response Time (0 - 90 %)
- blank: Standard (≤ 0.5 sec.)
  - /K: Fast Response (Approx. 25 msec.)
- Burnout
- blank: Upscale burnout
  - /BL: Downscale burnout
  - /BN: No burnout
- Other Options
- blank: none
  - /Q: Option other than the above (specify the specification)

#### SPECIFICATIONS OF OPTION: Q (multiple selections)

- COATING (For the detail, refer to our web site.)
- /C01: Silicone coating
  - /C02: Polyurethane coating
  - /C03: Rubber coating
- ADJUSTMENT
- /V01: Multi-turn fine adjustment
- TERMINAL SCREW MATERIAL
- /S01: Stainless steel

## GENERAL SPECIFICATIONS

**Construction:** Terminal block  
**Connection:** M3.5 screw terminals (torque 0.8 N·m)  
**Screw terminal:** Nickel-plated steel (standard) or stainless steel  
**Housing material:** Flame-resistant resin (black)  
**Isolation:** Input to output to power  
**Overrange output:** Approx. -10 to +110 % at 1 - 5 V  
**Zero adjustment:** -2 to +2 % (front)  
**Span adjustment:** 98 to 102 % (front)  
**At burnout:** Downscale  $\leq$  -10 %, Upscale  $\geq$  110 %,  
 For output code 4W, Downscale  $\leq$  -3%, Upscale  $\geq$  103%  
**Linearization:** Standard  
**Cold junction compensation:** CJC sensor attached to the input terminals  
**Power indicator LED:** Green LED turns on when the power is supplied.

## INPUT SPECIFICATIONS

**Minimum span:** 3 mV  
**Input resistance:** 20 k $\Omega$  min.  
**Burnout sensing:** 0.1  $\mu$ A

### Lower temperature range & span (in °C)

**(PR):** Lower range 0 to 880°C; min. span 370°C  
**K (CA):** Lower range -270 to +1200°C; min. span 75°C  
**E (CRC):** Lower range -270 to +750°C; min. span 50°C  
**J (IC):** Lower range -210 to +800°C; min. span 60°C  
**T (CC):** Lower range -270 to +325°C; min. span 75°C  
**B (RH):** Lower range 0 to 750°C; min. span 780°C  
**R:** Lower range -50 to +550°C; min. span 360°C  
**S:** Lower range -50 to +550°C; min. span 380°C  
**N:** Lower range -270 to +1100°C; min. span 110°C

### Lower temperature range & span (in °F)

**(PR):** Lower range 32 to 1616°F; min. span 670°F  
**K (CA):** Lower range -454 to +2192°F; min. span 140°F  
**E (CRC):** Lower range -454 to +1382°F; min. span 90°F  
**J (IC):** Lower range -346 to +1472°F; min. span 110°F  
**T (CC):** Lower range -454 to +617°F; min. span 140°F  
**B (RH):** Lower range 32 to 1382°F; min. span 1450°F  
**R:** Lower range -58 to +1022°F; min. span 680°F  
**S:** Lower range -58 to +1022°F; min. span 700°F  
**N:** Lower range -454 to +2012°F; min. span 200°F

**Note 1:** The described accuracy may be partially not satisfied when the temperature ranges below 0°C. Consult us.

**Note 2:** Consult us for the range out of the above list.

## OUTPUT SPECIFICATIONS

■ **DC Current:** 0 - 20 mA DC  
**Minimum span:** 1 mA  
**Offset:** Max. 1.5 times span  
**Load resistance:** Output drive 11 V max.  
 ■ **DC Voltage**  
 • **Output code 0 (CE)**  
**Voltage range:** -10 - +10 V DC  
**Minimum span:** 1 V  
**Offset:** Max. 1.5 times span  
**Load resistance:** Output drive 10 mA max.; at  $\geq$ 1 V  
 Max. 1.25 mA output drive for negative voltage  
 • **Output code 01 (Not CE)**  
**Voltage range:** -1 - +1 V DC  
**Minimum span:** 10 mV  
**Offset:** Max. 1.5 times span  
**Load resistance:** Min. 100 k $\Omega$   
 Min. 1 M $\Omega$  for negative voltage

## INSTALLATION

### Power Consumption

• **AC:**  
 Approx. 2 VA at 100 V  
 Approx. 3 VA at 200 V  
 Approx. 3 VA at 264 V

• **DC:** Approx. 2 W

**Operating temperature:** -5 to +55°C (23 to 131°F)

**Operating humidity:** 0 to 90 %RH (non-condensing)

**Mounting:** DIN rail

**Weight:** 80 g (2.8 oz)

## PERFORMANCE in percentage of span

**Accuracy** (whichever is greater)

**K, E, J:**  $\pm$ 0.1 % of FS or  $\pm$ 0.2°C ( $\pm$ 0.36°F)

**T, N:**  $\pm$ 0.2 % of FS or  $\pm$ 0.2°C ( $\pm$ 0.36°F)

**PR, B, R, S:**  $\pm$ 0.3 % of FS

(at over 400°C for R, S and PR; over 770°C for B)

**Cold junction compensation error**

(at 20°C  $\pm$ 10°C or 68°F  $\pm$ 18°F)

**K, E, J, T, N:**  $\pm$ 0.5°C or  $\pm$ 0.9°F

**S, R, PR:**  $\pm$ 1°C or  $\pm$ 1.8°F

**Temp. coefficient:**  $\pm$ 0.015 %/°C ( $\pm$ 0.008 %/°F)

(at over 400°C or 750°F for R, S and PR; over 770°C or 1420°F for B)

**Burnout response:**  $\leq$  10 sec.

**Line voltage effect:**  $\pm$ 0.1 % over voltage range

**Insulation resistance:**  $\geq$  100 M $\Omega$  with 500 V DC

**Dielectric strength** (input to output to power to ground)

**DC powered:** 2000 V AC @1 minute

**AC powered:** 1500 V AC @1 minute

**STANDARDS & APPROVALS**

**EU conformity:**

EMC Directive  
EMI EN 61000-6-4  
EMS EN 61000-6-2

RoHS Directive

**UK conformity (UKCA):**

The UK legislations and designated standards are equivalent to the applicable EU directives.  
(Refer to our website for more information about the legislations and designated standards.)

**FRONT VIEW**

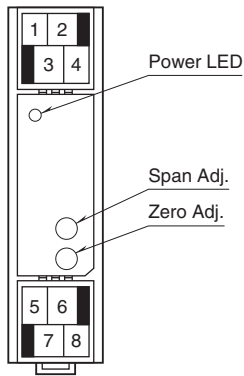

**EXTERNAL DIMENSIONS unit: mm [inch]**

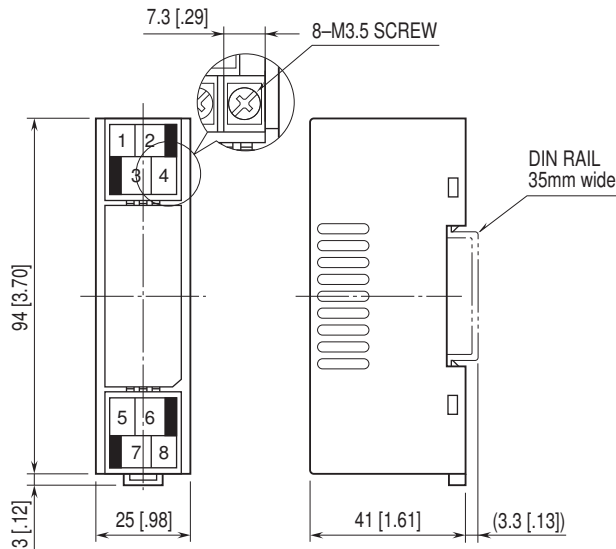

• When mounting, no extra space is needed between units.

**TERMINAL ASSIGNMENTS unit: mm [inch]**

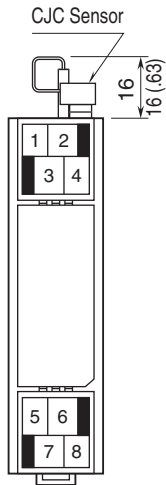

**SCHEMATIC CIRCUITRY & CONNECTION DIAGRAM**

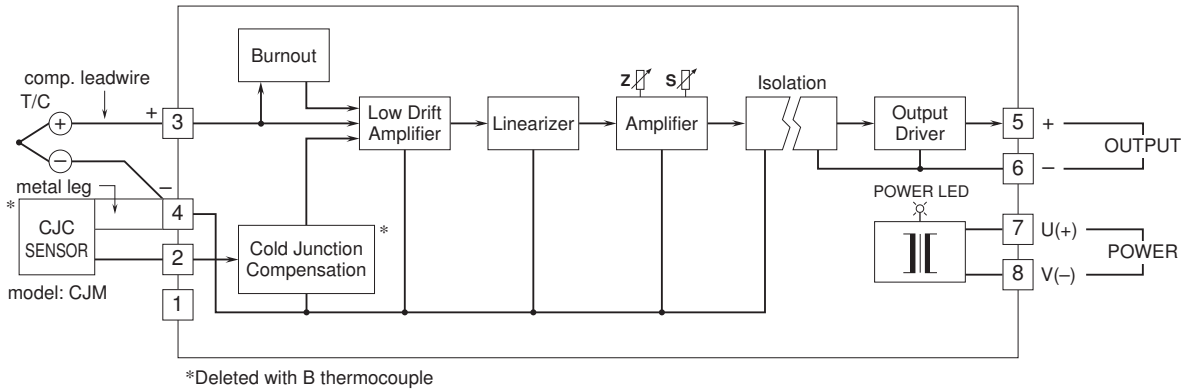

Specifications are subject to change without notice.