

Super-mini Terminal Block Signal Conditioners M5X-UNIT

INVERTED OUTPUT TRANSMITTER

(PC programmable)

Functions & Features

- Inverts 0% to 100% of the input signal
- PC programmable
- High-density mounting
- Power LED

Typical Applications

- Matching manipulating signal with the valve action

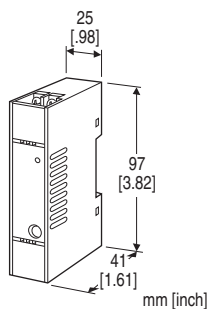

MODEL: M5XUDS-1-R[1]

ORDERING INFORMATION

- Code number: M5XUDS-1-R[1]
- Specify a code from below for [1].
(e.g. M5XUDS-1-R/Q)
- Specify the specification for option code /Q
(e.g. /C01/S01/SET)

INPUT - Field-selectable

◆ DC Input

- Current input: 0 - 50 mA DC
- Voltage input: -1000 - +1000 mV DC
- Voltage input: -10 - +10 V DC

EXTERNAL INTERFACE

◆ OUTPUT SIGNAL

- 1: DC output (field-selectable)
- Current output: 0 - 20 mA DC
 - Voltage output: -5 - +5 V DC
 - Voltage output: -10 - +10 V DC

POWER INPUT

DC Power

R: 24 V DC

(Operational voltage range 24 V \pm 10 %, ripple 10 %p-p max.)

[1] OPTIONS

blank: none

/Q: With options (specify the specification)

SPECIFICATIONS OF OPTION: Q (multiple selections)

COATING (For the detail, refer to our web site.)

/C01: Silicone coating

/C02: Polyurethane coating

/C03: Rubber coating

TERMINAL SCREW MATERIAL

/S01: Stainless steel

EX-FACTORY SETTING

/SET: Preset according to the Ordering Information Sheet
(No. ESU-2771)

RELATED PRODUCTS

- PC Configurator cable (model: COP-US)
 - PC configurator software (model: M5CFG)
- Downloadable at our web site.

GENERAL SPECIFICATIONS

Construction: Terminal block

Connection: M3.5 screw terminals (torque 0.8 N·m)

Screw terminal: Nickel-plated steel (standard) or stainless steel

Housing material: Flame-resistant resin (black)

Isolation: Input to output to power

Equation: $X_o = 100 \% - X_i$

Power indicator LED: Green LED; Blinking patterns indicate different operating status of the transmitter.

Parameters: Stored in non-volatile memory; write/erase cycle endurance: less than 20 000

Programming: Downloaded from PC;

- input type
- input range
- output type
- output range
- zero and span
- user's linearization table

For detailed information, refer to the users manual for the PC configurator.

Configurator connection: 2.5 dia. miniature jack;
RS-232-C level

INPUT SPECIFICATIONS

Standard default setting: DC current input 4 - 20 mA

■ DC Current

Input resistance: Incorporated (15.5 Ω)

Input range: 0 - 50 mA DC

Measurable range: 0 - 52.5 mA DC

Minimum span: 2 mA DC

Offset: Lower range can be any specific value within the input range provided that the minimum span is maintained.

■ **DC Voltage**

Input range

- S1: -1000 - +1000 mV DC
- S2: -10 - +10 V DC

Measurable range

- S1: -1100 - +1100 mV DC
- S2: -11 - +11 V DC

Minimum span:

- S1: 100 mV DC
- S2: 1 V DC

Offset: Lower range can be any specific value within the input range provided that the minimum span is maintained. If not specified, the input range is shown below.

Input resistance

- S1: $\geq 100 \text{ k}\Omega$
- S2: $\geq 1 \text{ M}\Omega$

OUTPUT SPECIFICATIONS

Standard default setting: DC current output 4 - 20 mA

Output type

- DC current output: 0 - 20 mA DC
 - DC voltage output: -10 - +10 V DC
 - DC voltage output: -5 - +5 V DC
- (3 types can be switched by DIP switch and PC)

■ **DC Current:** 0 - 20 mA DC

Output range: 0 - 23 mA DC

Minimum span: 1 mA

Load resistance: 550 Ω

■ **DC Voltage**

- **Output range -10 - +10 V DC**

Voltage range: -11.5 - +11.5 V DC

Minimum span: 1 V

Load resistance: Output drive 1 mA max.
(ex. 0 - 10 V DC: $10 \text{ V} \div 1 \text{ mA} = 10 \text{ k}\Omega$)

- **Output range -5 - +5 V DC**

Voltage range: -5.75 - +5.75 V DC

Minimum span: 500 mV

Load resistance: Output drive 1 mA max.
(ex. 1 - 5 V DC: $5 \text{ V} \div 1 \text{ mA} = 5000 \Omega$)

INSTALLATION

Power consumption: $\leq 1 \text{ W}$

Operating temperature: -20 to +65°C (-4 to +149°F)

Operating humidity: 30 to 90 %RH (non-condensing)

Atmosphere: No corrosive gas or heavy dust

Mounting: DIN rail

Weight: 80 g (2.8 oz)

PERFORMANCE in percentage of span

Input accuracy (% of max. input range): $\pm 0.01 \%$
($\pm 0.02 \%$ for current input)

Output accuracy (% of max. output range): $\pm 0.02 \%$
($\pm 0.04 \%$ for current output)

Temp. coefficient: $\pm 0.0075 \%/^{\circ}\text{C}$ ($\pm 0.004 \%/^{\circ}\text{F}$) of max. span

Response time: $\leq 500 \text{ msec.}$ (0 - 90 %)

Line voltage effect: $\pm 0.1 \%$ over voltage range

Insulation resistance: $\geq 100 \text{ M}\Omega$ with 500 V DC

Dielectric strength: 2000 V AC @1 minute (input to output to power to ground)

ACCURACY AND CALCULATION EXAMPLES

■ **Overall Accuracy**

The accuracy includes input accuracy, which converts the sensor input into a digital value, and output accuracy, which converts the digital value into an analog signal.

The accuracy of the device is the total of the input accuracy and the output accuracy.

Input accuracy

Input accuracy for the setting value span is shown as following formula.

Input accuracy = (input range \div input setting value span) $\times 0.01 \%$

For current input,

Input accuracy = (input range \div input setting value span) $\times 0.02 \%$

Output accuracy

Output accuracy for the setting value span is shown as following formula.

Output accuracy = (output range \div output setting value span) $\times 0.02 \%$

For current output,

Output accuracy = (output range \div output setting value span) $\times 0.04 \%$

Calculation examples

Ex1: Input 0 - 20 mA, output 4 - 20 mA

Input accuracy = (50 mA \div 20 mA) $\times 0.02 \%$ = 0.05 %

Output accuracy = (20 mA \div 16 mA) $\times 0.04 \%$ = 0.05 %

Accuracy = input accuracy 0.05 % + output accuracy 0.05 % = 0.1 %

Ex2: Input 0 - 10 V, output 0 - 10 V

Input accuracy = (20 V \div 10 V) $\times 0.01 \%$ = 0.02 %

Output accuracy = (20 V \div 10 V) $\times 0.02 \%$ = 0.04 %

Accuracy = input accuracy 0.02 % + output accuracy 0.04 % = 0.06 %

STANDARDS & APPROVALS

EU conformity:

EMC Directive

EMI EN 61000-6-4
 EMS EN 61000-6-2
 RoHS Directive

EXTERNAL VIEW

Refer to the instruction manual for the setting procedure.

■ LEFT VIEW

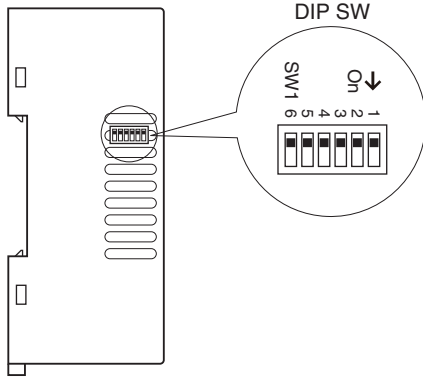

■ FRONT VIEW

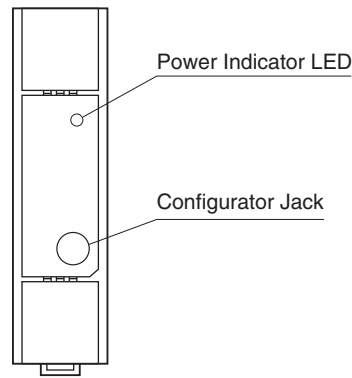

EXTERNAL DIMENSIONS & TERMINAL ASSIGNMENTS unit: mm [inch]

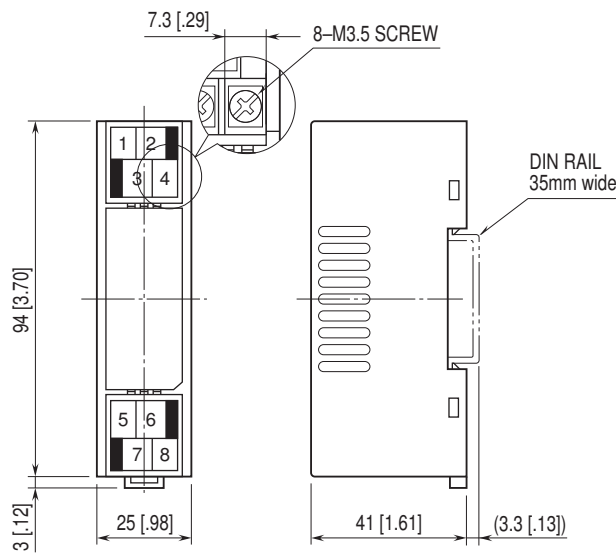

• When mounting, no extra space is needed between units.

SCHEMATIC CIRCUITRY & CONNECTION DIAGRAM

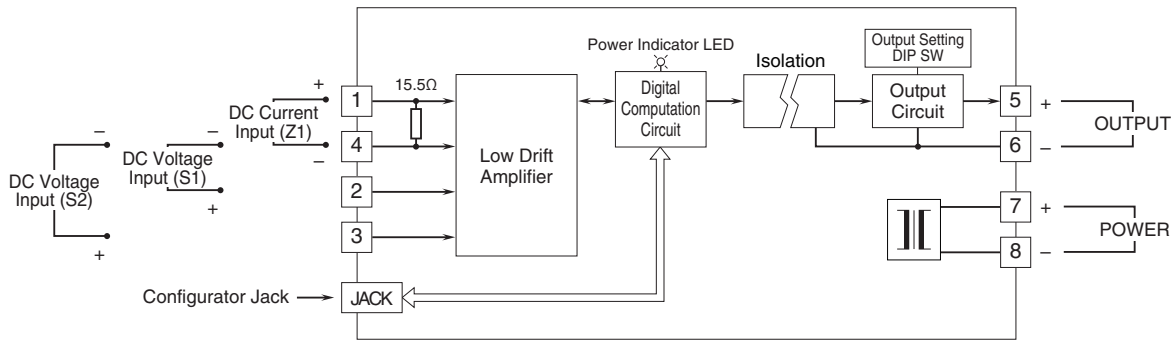

Specifications are subject to change without notice.