

Screw Terminal Ultra-Slim Signal Conditioners M6N Series

FREQUENCY TRANSMITTER

Functions & Features

- 7.5-mm wide ultra-slim design
- Low profile allows the M6N module mounted in a 120-mm deep panel
- Converts the output from a pulse-type transducer into a standard process signal
- High-density mounting
- Power indicator LED

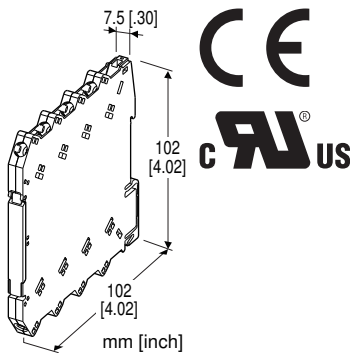

MODEL: M6NPA-[1][2]-R[3]

ORDERING INFORMATION

- Code number: M6NPA-[1][2]-R[3]
- Specify a code from below for each of [1] through [3].
(e.g. M6NPA-CA-R/UL/Q)
- Frequency range (e.g. 0 - 1 kHz)
 - Special output range (For codes Z & 0)
 - Specify the specification for option code /Q
(e.g. /C01)

[1] INPUT

- A1:** Open collector
- A2:** Mechanical contact
- C:** 5 V pulse (sensitivity 2 V)
- D:** 24 V pulse (sensitivity 10 V)

[2] OUTPUT

- Current
- A:** 4 - 20 mA DC (Load resistance 550 Ω max.)
 - Z:** Specify current (See OUTPUT SPECIFICATIONS)
- Voltage
- 4:** 0 - 10 V DC (Load resistance 10 kΩ min.)
 - 5:** 0 - 5 V DC (Load resistance 5000 Ω min.)
 - 6:** 1 - 5 V DC (Load resistance 5000 Ω min.)

- 4W:** -10 - +10 V DC (Load resistance 20 kΩ min.)
- 5W:** -5 - +5 V DC (Load resistance 10 kΩ min.)
- 0:** Specify voltage (See OUTPUT SPECIFICATIONS)

POWER INPUT

- DC Power
- R:** 24 V DC
(Operational voltage range 24 V ±10 %, ripple 10 %p-p max.)

[3] OPTIONS (multiple selections)

- Standards & Approvals
- blank:** CE marking
- /UL:** UL approval, CE marking
- Other Options
- blank:** none
- /Q:** Option other than the above (specify the specification)

SPECIFICATIONS OF OPTION: Q

- COATING (For the detail, refer to our web site.)
- /C01:** Silicone coating
- /C02:** Polyurethane coating

GENERAL SPECIFICATIONS

- Connection**
- Input and output:** M3 screw terminal (torque 0.5 N·m)
- Power input:** Via the Installation Base (model: M6NBS) or M3 screw terminal (torque 0.5 N·m)
- Recommended solderless terminal:** Max. 5.8 mm (0.23") wide; Ones with insulation sleeve do not fit.
- Applicable wire size: 0.2 - 2.5 mm²
- Housing material:** Flame-resistant resin (black)
- Isolation:** Input to output to power
- Zero adjustment:** -2 to +2 % (front)
(Output code 4W, 5W: Adjustable at 0V.)
- Span adjustment:** 98 to 102 % (front)
- Chattering protection:** Filter provided for mechanical contact input
- Power indicator LED:** Green LED turns on when the power is supplied.
- Recommended solderless terminal (unit: mm [inch])

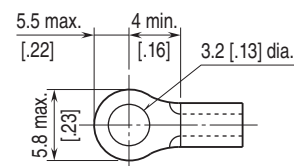

INPUT SPECIFICATIONS

- Open Collector
- Frequency range: 0 - 0.01 Hz through 100 kHz

Pulse width time requirement: $\geq 4 \mu\text{sec.}$ for both H and L levels

Sensing voltage/current: 2.5 V DC @1 mA (approx.)

Detecting levels: $\leq 750 \Omega/0.75 \text{ V}$ for ON;
 $\geq 3 \text{ k}\Omega/1.6 \text{ V}$ for OFF

■ **Mechanical Contact**

Frequency range: 0 - 0.01 Hz through 30 Hz

Pulse width time requirement: $\geq 10 \text{ msec.}$ for both ON and OFF

Sensing voltage/current: 2.5 V DC @1 mA (approx.)

Detecting levels: $\leq 750 \Omega/0.75 \text{ V}$ for ON;
 $\geq 3 \text{ k}\Omega/1.6 \text{ V}$ for OFF

■ **Voltage Pulse**

Frequency range: 0 - 0.01 Hz through 100 kHz

Pulse width time requirement: $\geq 4 \mu\text{sec.}$ for both H and L levels

Waveform: Square or sine

Input impedance: $\geq 10 \text{ k}\Omega$

Max. voltage between input terminals: $\pm 50 \text{ V}$

Detecting H level

5 V pulse: $\geq 3 \text{ V}$

24 V pulse: $\geq 14 \text{ V}$

Detecting L level

5 V pulse: $\leq 1 \text{ V}$

24 V pulse: $\leq 6 \text{ V}$

OUTPUT SPECIFICATIONS

■ **DC Current:** 2 - 20 mA DC (and 0 - 1 mA DC)

Minimum span: 1 mA

Offset: Max. 1.5 times span

Load resistance: Output drive 11 V max.

■ **DC Voltage:** 0 - 10 V DC

Minimum span: 1 V

Offset: Max. 1.5 times span

Load resistance: Output drive 1 mA max.; at $\geq 1 \text{ V}$

INSTALLATION

Power consumption: Approx. 0.5 W

Operating temperature: -20 to $+55^\circ\text{C}$ (-4 to $+131^\circ\text{F}$)

Operating humidity: 30 to 90 %RH (non-condensing)

Mounting: Installation Base (model: M6NBS) or DIN rail

Weight: 60 g (2.1 oz)

PERFORMANCE in percentage of span

Accuracy: $\pm 0.1 \%$

Temp. coefficient: $\pm 0.015 \%/^\circ\text{C}$ ($\pm 0.008 \%/^\circ\text{F}$)

Response time: Max. 0.5 sec. + 1 pulse cycle (0 - 90 %)

Line voltage effect: $\pm 0.1 \%$ over voltage range

Insulation resistance: $\geq 100 \text{ M}\Omega$ with 500 V DC

Dielectric strength: 2000 V AC @1 minute (input to output to power to ground)

STANDARDS & APPROVALS

EU conformity:

EMC Directive

EMI EN 61000-6-4

EMS EN 61000-6-2

RoHS Directive

Approval:

UL/C-UL nonincendive Class I, Division 2,

Groups A, B, C, and D hazardous locations

(ANSI/ISA-12.12.01, CAN/CSA-C22.2 No.213)

UL/C-UL general safety requirements

(UL 61010-1, CAN/CSA-C22.2 No.61010-1)

EXTERNAL VIEW

(With the cover open)

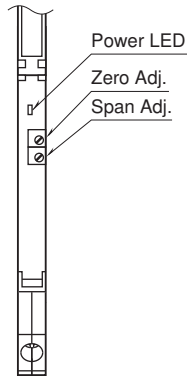

EXTERNAL DIMENSIONS & TERMINAL ASSIGNMENTS unit: mm [inch]

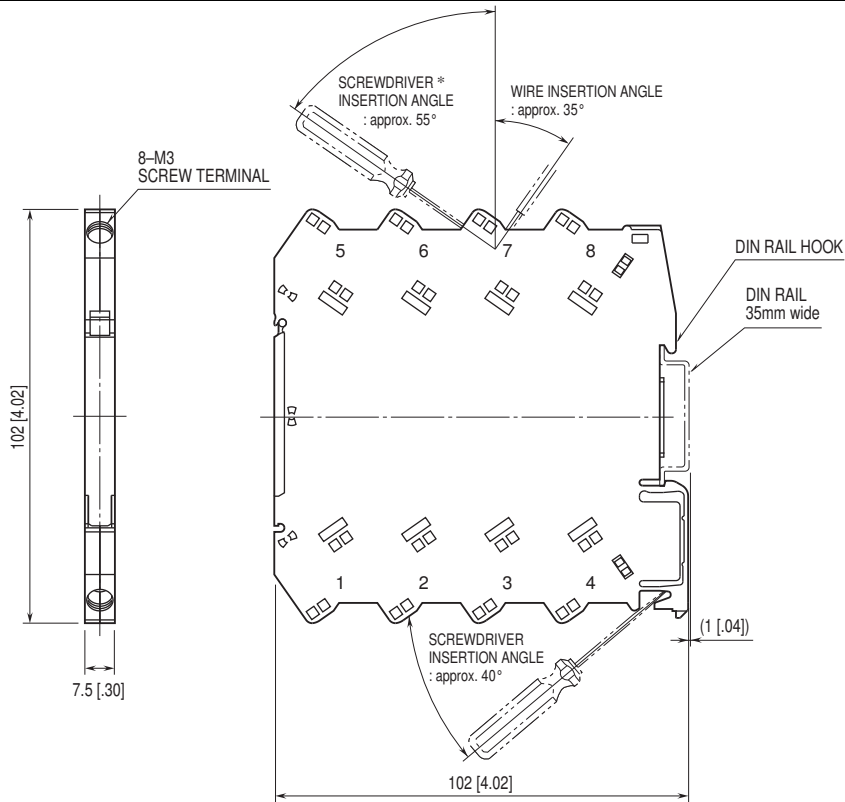

*Screwdriver stem diameter: 6 mm [.24"] or less

• When mounting, no extra space is needed between units.

SCHEMATIC CIRCUITRY & CONNECTION DIAGRAM

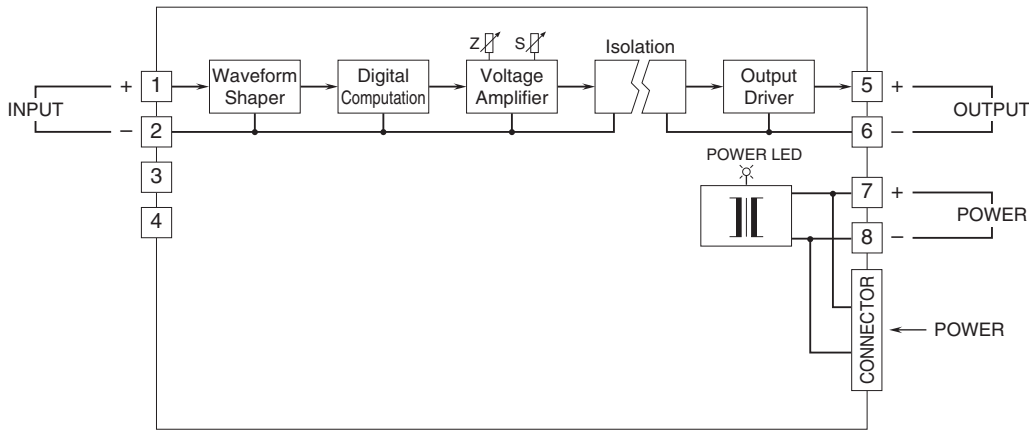

Input Connection Examples

■ Open Collector or Mechanical Contact

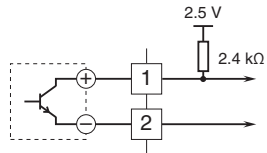

■ Voltage Pulse

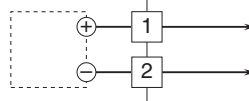

Specifications are subject to change without notice.