

Screw Terminal Ultra-Slim Signal Conditioners M6N Series

INPUT LOOP POWERED ISOLATOR

Functions & Features

- 7.5-mm wide ultra-slim design
- Low profile allows the M6N module mounted in a 120-mm deep panel
- Loop-powered design eliminates output loop power supply
- Two isolators housed in one enclosure
- High-density mounting

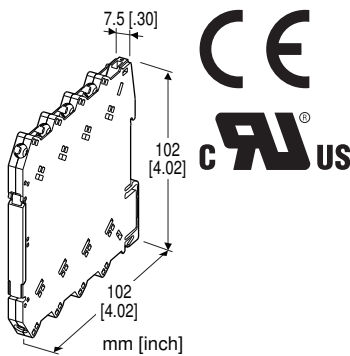

MODEL: M6NSN-[1]DD[2]

ORDERING INFORMATION

- Code number: M6NSN-[1]DD[2]
- Specify a code from below for each of [1] and [2].
(e.g. M6NSN-2DD/UL/Q)
- Specify the specification for option code /Q
(e.g. /C01)

[1] NO. OF CHANNELS

- 1: 1 channel
- 2: 2 channels

INPUT

Current
D: 0 - 20 mA DC (4 - 20 mA DC)

OUTPUT

Current
D: 0 - 20 mA DC (4 - 20 mA DC)

[2] OPTIONS (multiple selections)

Standards & Approvals
blank: CE marking
/UL: UL approval, CE marking

Other Options

blank: none

/Q: Option other than the above (specify the specification)

SPECIFICATIONS OF OPTION: Q

COATING (For the detail, refer to our web site.)

/C01: Silicone coating

/C02: Polyurethane coating

GENERAL SPECIFICATIONS

Connection: M3 screw terminal (torque 0.5 N·m)

Recommended solderless terminal: Max. 5.8 mm (0.23") wide; Ones with insulation sleeve do not fit.

Applicable wire size: 0.2 - 2.5 mm²

Housing material: Flame-resistant resin (black)

Isolation: Input to output; between channels

Span adjustments: ±0.5 % (front)

■ Recommended solderless terminal (unit: mm [inch])

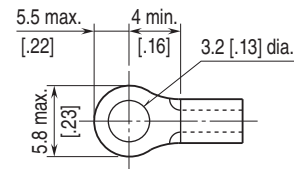

INPUT & OUTPUT

Equivalent input impedance: 250 Ω plus load resistance with 20 mA input

Operational range: 0.05 - 40 mA DC (Accuracy is assured within 0.05 - 22 mA)

Minimum operating current: 0.05 mA

Load resistance: 0 - 600 Ω

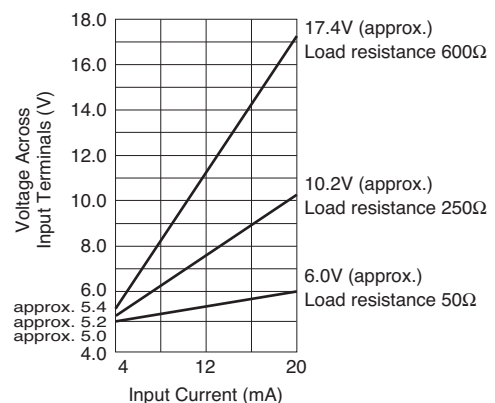

INSTALLATION

Operating temperature: -20 to +55°C (-4 to +131°F)

Operating humidity: 30 to 90 %RH (non-condensing)

Mounting: Installation Base (model: M6NBS) or DIN rail

Weight: 60 g (2.1 oz)

PERFORMANCE in percentage of span

Accuracy: $\pm 0.1\%$

Temp. coefficient: $\pm 0.015\%/^{\circ}\text{C}$ ($\pm 0.008\%/^{\circ}\text{F}$)

Response time: Approx. 20 msec. (0 - 90 %, 250 Ω load)

Load effect: (factory-calibrated with 250 Ω load)

0.004%/ Ω (0 - 600 Ω)

Insulation resistance: $\geq 100\text{ M}\Omega$ with 500 V DC

Dielectric strength:

1500 V AC @1 minute (input to output)

2000 V AC @1 minute (between channels)

2000 V AC @1 minute (input or output to ground)

STANDARDS & APPROVALS

EU conformity:

EMC Directive

EMI EN 61000-6-4

EMS EN 61000-6-2

RoHS Directive

Approval:

UL/C-UL nonincendive Class I, Division 2,

Groups A, B, C, and D hazardous locations

(ANSI/ISA-12.12.01, CAN/CSA-C22.2 No.213)

UL/C-UL general safety requirements

(UL 61010-1, CAN/CSA-C22.2 No.61010-1)

EXTERNAL VIEW

(With the cover open)

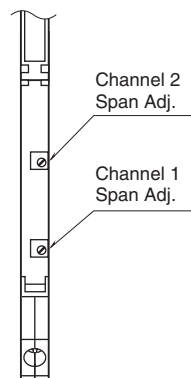

EXTERNAL DIMENSIONS & TERMINAL ASSIGNMENTS unit: mm [inch]

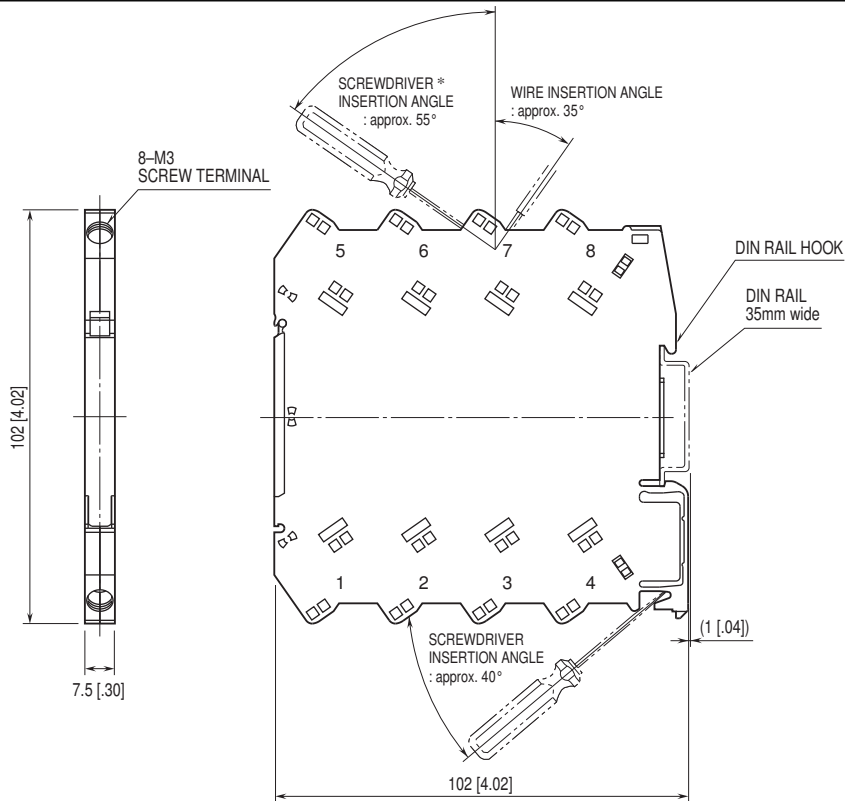

*Screwdriver stem diameter: 6 mm [.24"] or less • When mounting, no extra space is needed between units.

SCHEMATIC CIRCUITRY & CONNECTION DIAGRAM

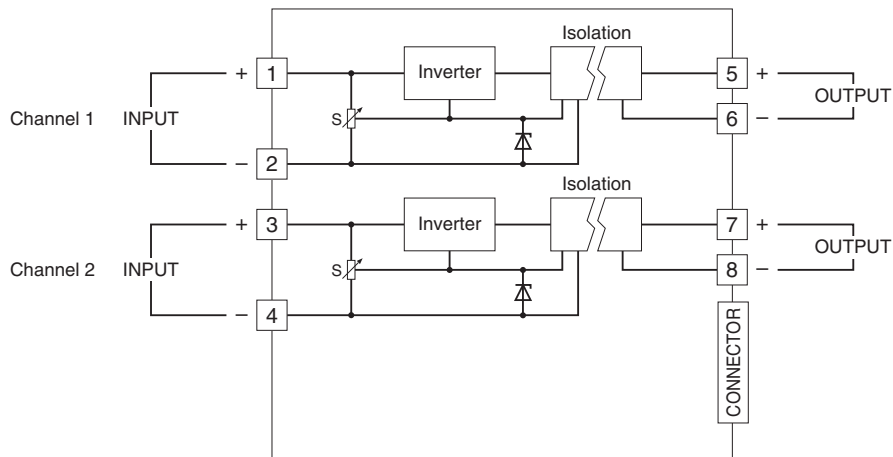

Specifications are subject to change without notice.