

Screw Terminal Ultra-Slim Signal Conditioners M6N Series

FUNCTION MODULE

(PC programmable)

Functions & Features

- Single input filter and function module
- 12 types of functions are PC programmable
- 7.5-mm wide ultra-slim design
- Low profile allows the M6N module mounted in a 120-mm deep panel
- High-density mounting
- Power and status indicator LEDs

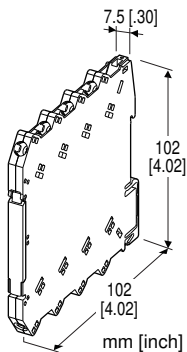

MODEL: M6NXF1-[1][2]-R[3]

ORDERING INFORMATION

- Code number: M6NXF1-[1][2]-R[3]
- Specify a code from below for each of [1] through [3].
(e.g. M6NXF1-Z1Z1-R/Q)
- Input range (e.g. 4 - 20 mA DC)
 - Output range (e.g. 4 - 20 mA DC)
 - Specify the specification for option code /Q
(e.g. /C01/SET)

[1] INPUT

Current

Z1: Range 0 - 50 mA DC (Input resistance 24.9 Ω)

Voltage

S1: Range -1000 - +1000 mV DC (Input resistance 1 MΩ min.)

S2: Range -10 - +10 V DC (Input resistance 1 MΩ min.)

(Configurator software is used to change the input type and precise range.)

[2] OUTPUT

Current

Z1: Range 0 - 20 mA DC

Voltage

V2: Range -10 - +10 V DC

V3: Range -5 - +5 V DC

(Configurator software is used to change output over the described range of the selected suffix code.

For changing between suffix codes, set the Output Range Selector on the side of unit before software adjustment.)

POWER INPUT

DC Power

R: 24 V DC

(Operational voltage range 24 V ±10 %, ripple 10 %p-p max.)

[3] OPTIONS

Other Options

blank: none

/Q: Option other than the above (specify the specification)

SPECIFICATIONS OF OPTION: Q (multiple selections)

COATING (For the detail, refer to our web site.)

/C01: Silicone coating

/C02: Polyurethane coating

EX-FACTORY SETTING

/SET: Preset according to the Ordering Information Sheet
(No. ESU-7847)

FUNCTIONS

PC Configurator Software is used to program the function. Filter, linearization and limiter functions can be combined.

- Filter / Lag
- Moving average output
- Dead time computing
- Delay buffer (first order lag)
- Lead time computing
- Ramp buffer
- Linearization
- User's table linearization
- Inverted output
- Square root extraction (orifice, venturi)
- X^2 (Palmer-Bowlus flume, Parshall flume)
- $X^{5/2}$ (triangular or v-notch weir)
- $X^{3/2}$ (rectangular weir)
- Limiter
- High / Low limit

Factory default function setting

Filter: Moving average

(H = 0.1, N = 1, U = 0, L = 0)

Linearization: None

Limiter: Low limit = -2 %, High limit = 102 %

RELATED PRODUCTS

- PC configurator software (model: M6CFG)
Downloadable at our web site.

A dedicated cable is required to connect the module to the PC. Please refer to the internet software download site or the users manual for the PC configurator for applicable cable types.

GENERAL SPECIFICATIONS

Connection

Input and output: M3 screw terminal (torque 0.5 N·m)

Power input: Via the Installation Base (model: M6NBS) or M3 screw terminal (torque 0.5 N·m)

Recommended solderless terminal: Max. 5.8 mm (0.23") wide; Ones with insulation sleeve do not fit.

Applicable wire size: 0.2 - 2.5 mm²

Housing material: Flame-resistant resin (black)

Isolation: Input to output to power

Overrange output: -2 - +102 %

(Negative current output is not available.)

Zero adjustment: -2 to +2 % (PC programming)

Span adjustment: 98 to 102 % (PC programming)

Power indicator LED: Green LED turns on when the power is supplied.

Status indicator LED: Orange LED; Blinking patterns indicate different operating status of the transmitter.

Programming: Downloaded from PC; input type and range, output type and range, zero and span, function type and parameters, etc.

For detailed information, refer to the users manual for the PC configurator.

Configurator connection: 2.5 dia. miniature jack; RS-232-C level

■ Recommended solderless terminal (unit: mm [inch])

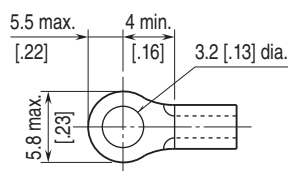

INPUT SPECIFICATIONS

■ **DC Current:** Input resistor incorporated (If not specified, the input range is 4 - 20 mA DC.)

Input range: 0 - 50 mA DC

Minimum span: 2 mA

Offset: Lower range can be any specific value within the input range provided that the minimum span is maintained.

■ DC Voltage

• Code S1 (narrow spans)

Input range: -1000 - +1000 mV DC

Minimum span: 100 mV

• Code S2 (wide spans)

Input range: -10 - +10 V DC

Minimum span: 1 V

Offset: Lower range can be any specific value within the input range provided that the minimum span is maintained. If not specified, the input range is shown below.

S1: 0 - 100 mV DC

S2: 1 - 5 V DC

OUTPUT SPECIFICATIONS

■ DC Current

Output range: 0 - 20 mA DC

Conformance range: 0 - 20.4 mA DC

Minimum span: 1 mA

Offset: Lower range can be any specific value within the output range provided that the minimum span is maintained.

Load resistance: Output drive 11 V max.

(e.g. 4 - 20 mA: 550 Ω [11 V ÷ 20 mA])

If not specified, the output range is 4 - 20 mA DC.

■ DC Voltage

Code V2 (wide spans)

Output range: -10 - +10 V DC

Conformance range: -10.4 - +10.4 V DC

Minimum span: 1 V

Code V3 (narrow spans)

Output range: -5 - +5 V DC

Conformance range: -5.2 - +5.2 V DC

Minimum span: 0.5 V

Offset: Lower range can be any specific value within the output range provided that the minimum span is maintained.

Load resistance: Output drive 1 mA max.

(e.g. 1 - 5 V: 5000 Ω [5 V ÷ 1 mA])

If not specified, the output range is shown below.

V2: 0 - 10 V DC

V3: 1 - 5 V DC

INSTALLATION

Power consumption: Approx. 0.5 W

Operating temperature: -20 to +55°C (-4 to +131°F)

Operating humidity: 30 to 90 %RH (non-condensing)

Mounting: Installation Base (model: M6NBS) or DIN rail

Weight: 65 g (2.3 oz)

PERFORMANCE in percentage of span

Overall accuracy

I/O gain ≤ 1: Input accuracy + Output accuracy

I/O gain > 1: [Input accuracy + Output accuracy] × I/O gain

• **Input accuracy*:** (% of max. input range)

-1000 - +1000 mV : ±0.01 %

-10 - +10 V : ±0.01 %

0 - 50 mA : ±0.02 %

- **Output accuracy***: ± 0.04 % of max. output range

*Inversely proportional to the span.

See CALCULATION EXAMPLES OF OVERALL ACURACY.

Temp. coefficient: ± 0.01 %/°C (± 0.006 %/°F) of max. span

Response time: ≤ 0.5 sec. (0 - 90 %) without any function setting

Line voltage effect: ± 0.1 % over voltage range

Insulation resistance: ≥ 100 M Ω with 500 V DC

Dielectric strength: 2000 V AC @1 minute (input to output to power to ground)

CALCULATION EXAMPLES OF OVERALL ACCURACY

[Example] Input Type -10 - +10 V, Input Range 1 - 5 V,

Output Type -5 - +5 V, Output Range 1 - 5 V

• Input accuracy = Max. Input Range (20 V) \div Span (4 V) \times 0.01 % = 0.05 %

• Output accuracy = Max. Output Range (10 V) \div Span (4 V) \times 0.04 % = 0.1 %

Accuracy = ± 0.15 %

STANDARDS & APPROVALS

EU conformity:

EMC Directive

EMI EN 61000-6-4

EMS EN 61000-6-2

RoHS Directive

EXTERNAL VIEW

FRONT VIEW (with the cover open)

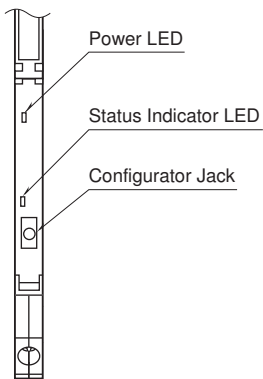

SIDE VIEW

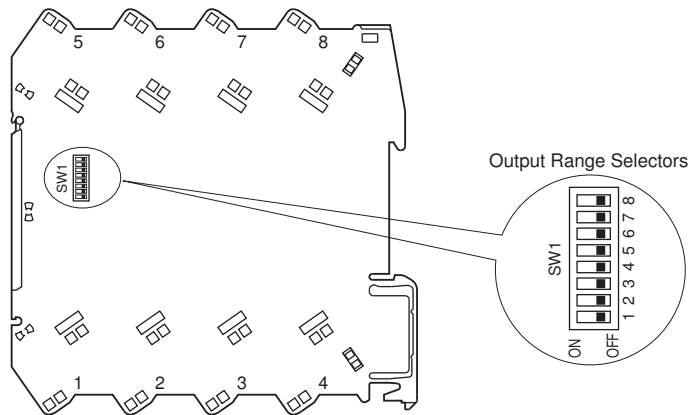

The DIP switch setting is required to select output types before setting a precise output range using PC Configurator Software (model: M6CFG). Refer to the instruction manual for detailed procedures.

EXTERNAL DIMENSIONS & TERMINAL ASSIGNMENTS unit: mm [inch]

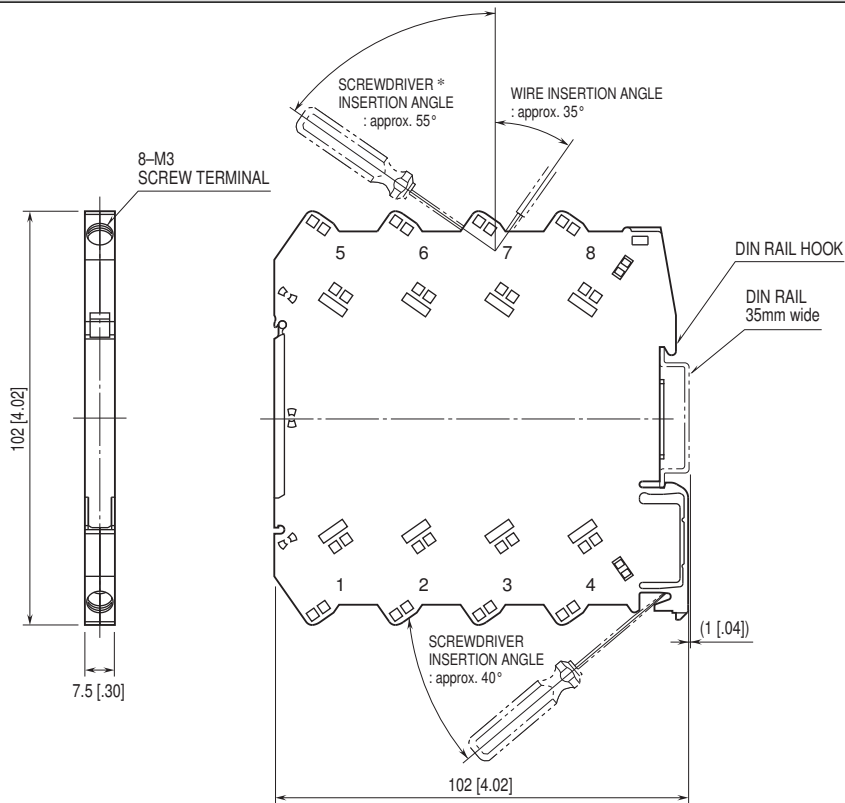

*Screwdriver stem diameter: 6 mm [.24"] or less

• When mounting, no extra space is needed between units.

SCHEMATIC CIRCUITRY & CONNECTION DIAGRAM

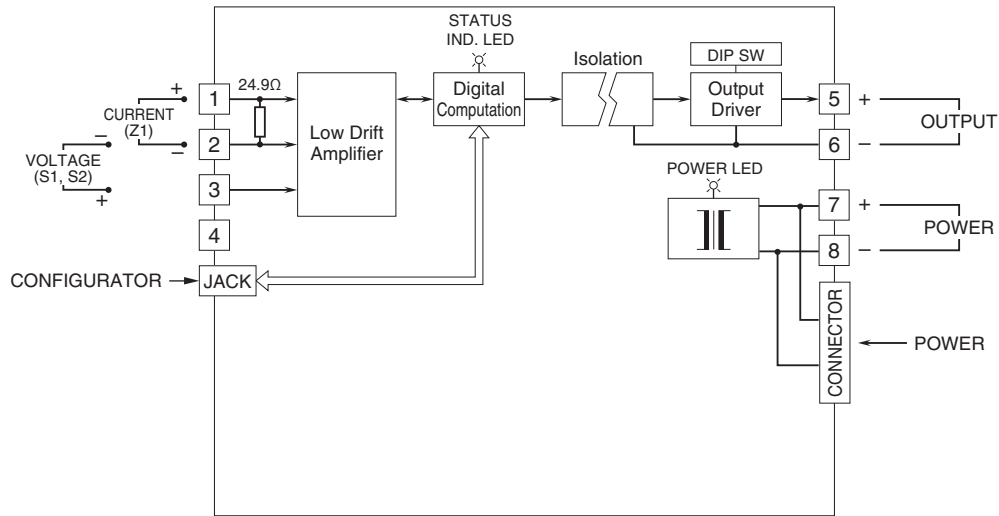

FUNCTIONS

MOVING AVERAGE OUTPUT

The module samples input signals every H seconds and, excluding U numbers of highest-value samples and L numbers of lowest-value samples, outputs proportionally to the average of the rest [N - (U + L)] of sampled data. When a new input is sampled after another H seconds, it gives up the oldest sample and calculates a new average including the latest sample and outputs proportionally. When the number of samples to be calculated equals 0 or less, it outputs an error.

Parameters

- H:** Sampling cycle
(0.1000 to 100.0000 seconds)
- N:** Number of samples to be calculated
(1 to 128)
- U:** Number of highest-value samples to be cut off
(0 to 127)
- L:** Number of lowest-value samples to be cut off
(0 to 127)

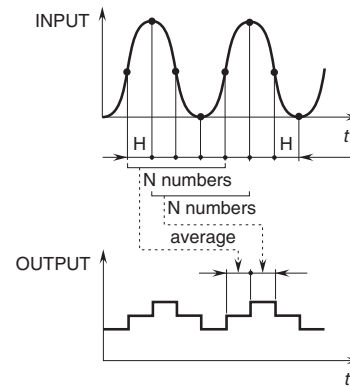

DEAD-TIME COMPUTING

The module does not respond to an input signal for a preset dead-time* duration. In addition, with adjusting a time constant T, it generates a first order lag output after the dead-time.

$$X_0(s) = \frac{e^{-HNs}}{1 + Ts} X_1(s)$$

where X₁: Input
X₀: Output

Dead time = H x N (s)

Parameters

- H:** Sampling cycle (0.1000 to 100.0000 seconds)
- N:** Numbers of samples to be calculated (1 to 128)
- T:** Time constant (0.0000 or 0.5000 to 100.0000 seconds)

*Output is refreshed every sampling cycle. The response time may be delayed by 1 cycle at the maximum.

Step input with dead-time

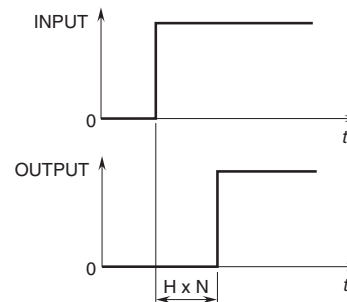

Step input with dead-time plus time constant

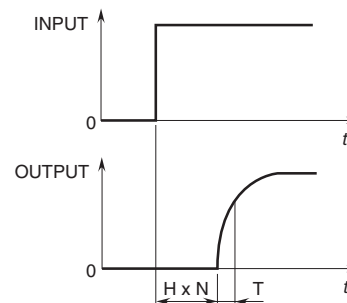

DELAY BUFFER

The module generates a first order lag output.

$$X_0(s) = \frac{1}{1 + Ts} X_1(s)$$

where X₁: Input
X₀: Output

Parameters

- T:** Time constant (0.5000 to 100.0000 seconds)

Step input with time constant

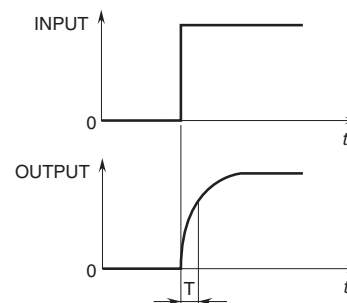

■ LEAD-TIME COMPUTING

The module operates a lead-time equation.

$$X_0(s) = (1 + Ts) X_1(s)$$

where X_1 : Input
 X_0 : Output

Parameters

T: Lead-time constant (0.5000 to 100.0000 seconds)

• Step input with lead-time constant

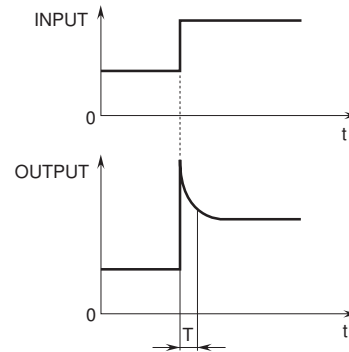

■ RAMP BUFFER

The module's output does not change faster than a preset maximum rate, positive CP and negative CN, no matter how fast its input changes.

CP: Maximum rate of positive output change
(0.0000 to 200.0000%/second)

CN: Maximum rate of negative output change
(0.0000 to 200.0000%/second)

• Step input with rate-of-change limits

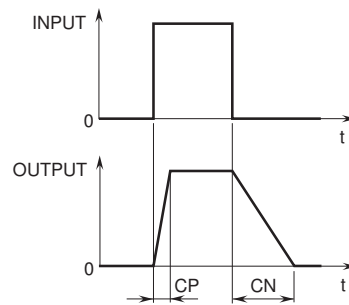

■ HIGH / LOW LIMIT

The output does not go above the preset high limit or below the preset low limit.
High and Low limits are independently selectable.

■ X^2 OUTPUT (Palmer-Bowlius flume, Parshall flume)

$$X_0 = X_1^2 / 100$$

where X_1 : Input (%)
 X_0 : Output (%)

■ USER'S TABLE LINEARIZATION

The input is converted into a linearized output according to the user specified segment data table, defined with pairs of X (input) and Y (output) values.
2 to 101 segment points can be specified.

■ $X^{5/2}$ OUTPUT (triangular or V-notch weir)

$$X_0 = X_1^{5/2} / 1000$$

where X_1 : Input (%)
 X_0 : Output (%)

■ INVERTED OUTPUT

The output is inversely proportional to the input.

$$X_0 = 100 - X_1$$

where X_1 : Input (%)
 X_0 : Output (%)

■ $X^{3/2}$ OUTPUT (rectangular weir)

$$X_0 = X_1^{3/2} / 10$$

where X_1 : Input (%)
 X_0 : Output (%)

■ SQUARE ROOT EXTRACTION (orifice, venturi)

The output is square root of input.

$$X_0 = 10 \sqrt{X_1}$$

where X_1 : Input (%)
 X_0 : Output (%)

■ OTHER FUNCTIONS

The low-end cutout point can be set within 0.0000 – 99.9999% of input signal.



Specifications are subject to change without notice.