

Screw Terminal Ultra-Slim Signal Conditioners M6N Series

POTENTIOMETER TRANSMITTER

(PC programmable)

Functions & Features

- 7.5-mm wide ultra-slim design
- Low profile allows the M6N module mounted in a 120-mm deep panel
- Provides a DC output proportional to a potentiometer or slidewire position input
- Linearization and burnout protection
- PC programmable
- High-density mounting
- Power indicator LED

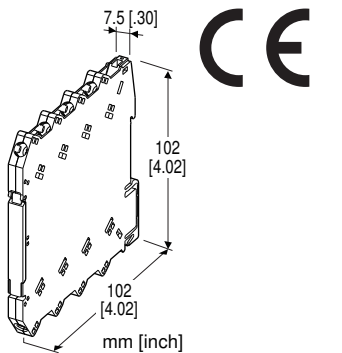

MODEL: M6NXM-1[1]-R[2]

ORDERING INFORMATION

- Code number: M6NXM-1[1]-R[2]
- Specify a code from below for each of [1] and [2].
(e.g. M6NXM-1Z1-R/Q)
- Potentiometer range (total resistance) (e.g. 0 - 1000 Ω)
 - Output range (e.g. 4 - 20 mA DC)
 - Specify the specification for option code /Q
(e.g. /C01)

INPUT

1: Total resistance 100 - 5000 Ω
(Configurator software is used to change the input range.)

[1] OUTPUT

Current

Z1: Range 0 - 20 mA DC

Voltage

V2: Range -10 - +10 V DC

V3: Range -5 - +5 V DC

(Configurator software is used to change output over the

described range of the selected suffix code.

For changing between suffix codes, set the Output Range Selector on the side of unit before software adjustment.)

POWER INPUT

DC Power

R: 24 V DC

(Operational voltage range 24 V \pm 10 %, ripple 10 %p-p max.)

[2] OPTIONS

Other Options

blank: none

/Q: Option other than the above (specify the specification)

SPECIFICATIONS OF OPTION: Q

COATING (For the detail, refer to our web site.)

/C01: Silicone coating

/C02: Polyurethane coating

RELATED PRODUCTS

- PC configurator software (model: M6CFG)

Downloadable at our web site.

A dedicated cable is required to connect the module to the PC. Please refer to the internet software download site or the users manual for the PC configurator for applicable cable types.

GENERAL SPECIFICATIONS

Connection

Input and output: M3 screw terminal (torque 0.5 N·m)

Power input: Via the Installation Base (model: M6NBS) or M3 screw terminal (torque 0.5 N·m)

Recommended solderless terminal: Max. 5.8 mm (0.23") wide; Ones with insulation sleeve do not fit.

Applicable wire size: 0.2 - 2.5 mm²

Housing material: Flame-resistant resin (black)

Isolation: Input to output to power

Overrange output: -2 - +102 %

(Negative current output is not available.)

Zero adjustment: -2 to +2 % (PC programming)

Span adjustment: 98 to 102 % (PC programming)

Burnout: Upscale standard; downscale or no burnout optional by programming

Power indicator LED: Green LED turns on when the power is supplied.

Status indicator LED: Orange LED; Blinking patterns indicate different operating status of the transmitter.

Programming: Downloaded from PC; input type (range), output type and range, zero and span, burnout type, user's linearization table, etc.

For detailed information, refer to the users manual for the PC configurator.

Configurator connection: 2.5 dia. miniature jack;
RS-232-C level

■ Recommended solderless terminal (unit: mm [inch])

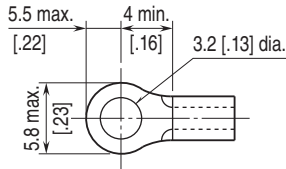

INPUT SPECIFICATIONS

Sensing current: ≤ 0.15 mA

Minimum span of each range

0 - 100 Ω : 10 Ω

0 - 300 Ω : 30 Ω

0 - 600 Ω : 60 Ω

0 - 1200 Ω : 120 Ω

0 - 2500 Ω : 250 Ω

0 - 5000 Ω : 500 Ω

If not specified, the input range is 0 - 1200 Ω .

OUTPUT SPECIFICATIONS

■ DC Current

Output range: 0 - 20 mA DC

Conformance range: 0 - 20.4 mA DC

Minimum span: 1 mA

Offset: Lower range can be any specific value within the output range provided that the minimum span is maintained.

Load resistance: Output drive 11 V max.

(e.g. 4 - 20 mA: 550 Ω [11 V \div 20 mA])

If not specified, the output range is 4 - 20 mA DC.

■ DC Voltage

Code V2 (wide spans)

Output range: -10 - +10 V DC

Conformance range: -10.4 - +10.4 V DC

Minimum span: 1 V

Code V3 (narrow spans)

Output range: -5 - +5 V DC

Conformance range: -5.2 - +5.2 V DC

Minimum span: 0.5 V

Offset: Lower range can be any specific value within the output range provided that the minimum span is maintained.

Load resistance: Output drive 1 mA max.

(e.g. 1 - 5 V: 5000 Ω [5 V \div 1 mA])

If not specified, the output range is shown below.

V2: 0 - 10 V DC

V3: 1 - 5 V DC

INSTALLATION

Power consumption: Approx. 0.5 W

Operating temperature: -20 to +55°C (-4 to +131°F)

Operating humidity: 30 to 90 %RH (non-condensing)

Mounting: Installation Base (model: M6NBS) or DIN rail

Weight: 65 g (2.3 oz)

PERFORMANCE in percentage of span

Overall accuracy: Input accuracy + output accuracy

Inversely proportional to the span.

See CALCULATION EXAMPLES OF OVERALL ACURACY.

• **Input accuracy:** (% of range)

0 - 100 Ω : ± 0.05 %

0 - 300 Ω : ± 0.05 %

0 - 600 Ω : ± 0.03 %

0 - 1200 Ω : ± 0.03 %

0 - 2500 Ω : ± 0.01 %

0 - 5000 Ω : ± 0.01 %

• **Output accuracy:** ± 0.04 % of max. output range

Temp. coefficient: ± 0.01 %/°C (± 0.006 %/°F) of max. span

Response time: ≤ 1 sec. (0 - 90 %)

Burnout response: ≤ 10 sec.

Line voltage effect: ± 0.1 % over voltage range

Insulation resistance: ≥ 100 M Ω with 500 V DC

Dielectric strength: 2000 V AC @1 minute (input to output to power to ground)

CALCULATION EXAMPLES OF OVERALL ACCURACY

[Example] Total Resistance 0 - 1200 Ω , Input Range 250-

750 Ω , Output Type -5 - +5 V, Output Range 1 - 5 V

Max. Input Range (1200 Ω) \div Span (500 Ω) \times 0.01 %

+ Max. Output Range (10 V) \div Span (4 V) \times 0.04 %

= 0.18 %

STANDARDS & APPROVALS

EU conformity:

EMC Directive

EMI EN 61000-6-4

EMS EN 61000-6-2

RoHS Directive

EXTERNAL VIEW

FRONT VIEW (with the cover open)

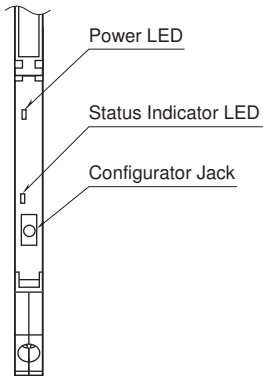

SIDE VIEW

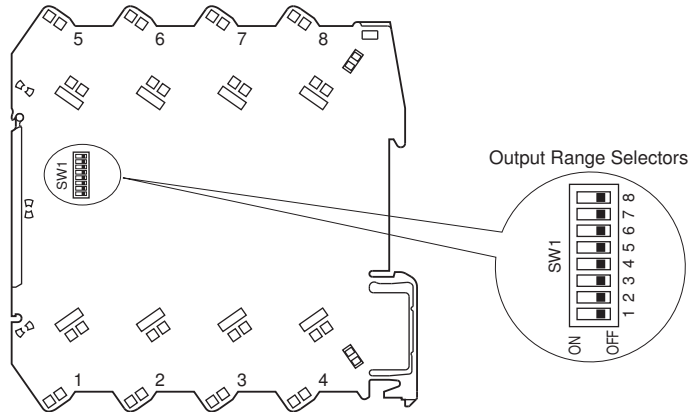

The DIP switch setting is required to select output types before setting a precise output range using PC Configurator Software (model: M6CFG). Refer to the instruction manual for detailed procedures.

EXTERNAL DIMENSIONS & TERMINAL ASSIGNMENTS unit: mm [inch]

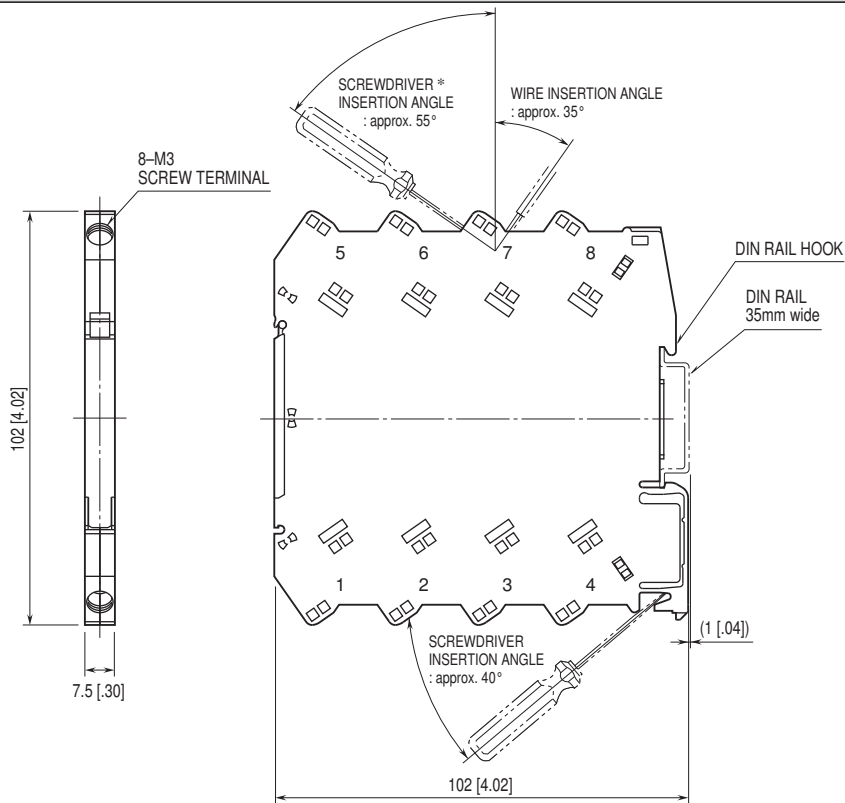

*Screwdriver stem diameter: 6 mm [.24"] or less

• When mounting, no extra space is needed between units.

SCHEMATIC CIRCUITRY & CONNECTION DIAGRAM

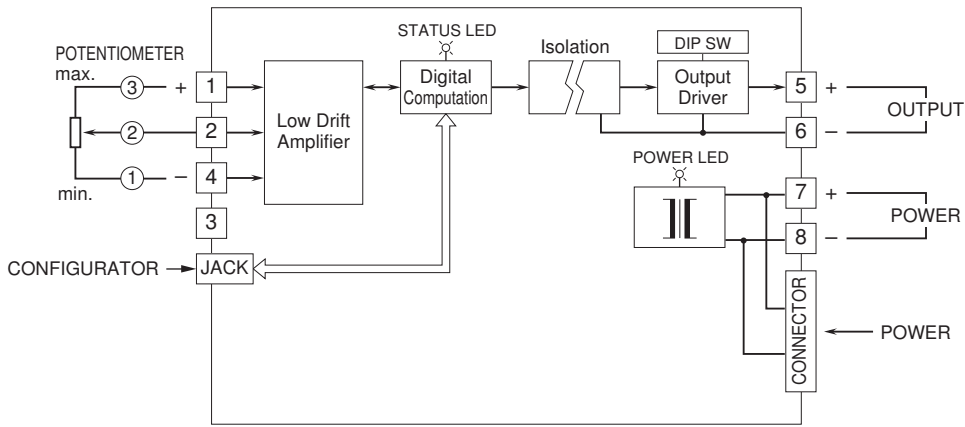

Specifications are subject to change without notice.