

Tension-Clamp Ultra-Slim Signal Conditioners M6S Series

2-INPUT MATH FUNCTION MODULE

(PC programmable)

Functions & Features

- Maintenance-free tension clamp connection
- 5.9-mm wide ultra-slim design
- Low profile allows the M6S module mounted in a 120-mm deep panel
- 2-input math functions and signal selector functions
- PC programmable
- High-density mounting
- Power indicator LED

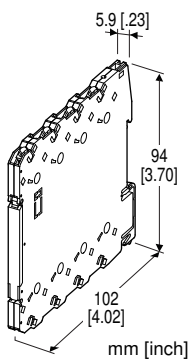

MODEL: M6SXF2-[1][2][3]-R[4]

ORDERING INFORMATION

- Code number: M6SXF2-[1][2][3]-R[4]
- Specify a code from below for each of [1] through [4].
(e.g. M6SXF2-S2Z1Z1-R/Q)
- Input 1 range (e.g. 1 - 5 V DC)
 - Input 2 range (e.g. 4 - 20 mA DC)
 - Output range (e.g. 4 - 20 mA DC)
 - Specify the specification for option code /Q (e.g. /C01/SET)

[1] INPUT 1

Current

Z1: Range 0 - 50 mA DC (Input resistance 24.9 Ω)

Voltage

S1: Range -1000 - +1000 mV DC (Input resistance 1 MΩ min.)

S2: Range -10 - +10 V DC (Input resistance 1 MΩ min.)

(Configurator software is used to change the input type and precise range.)

[2] INPUT 2

Same range availability as Input 1

(Configurator software is used to change the input type and

precise range.)

[3] OUTPUT

Current

Z1: Range 0 - 20 mA DC

Voltage

V2: Range -10 - +10 V DC

V3: Range -5 - +5 V DC

(Configurator software is used to change the output type and precise range.)

POWER INPUT

DC Power

R: 24 V DC

(Operational voltage range 24 V ±10 %, ripple 10 %p-p max.)

[4] OPTIONS

blank: none

/Q: With options (specify the specification)

SPECIFICATIONS OF OPTION: Q (multiple selections)

COATING (For the detail, refer to our web site.)

/C01: Silicone coating

/C02: Polyurethane coating

EX-FACTORY SETTING

/SET: Preset according to the Ordering Information Sheet (No. ESU-7848)

FUNCTIONS

PC Configurator Software is used to change function type.

Math Functions:

Temperature compensation (w/o square root extraction)

Temperature compensation (with square root extraction)

Pressure compensation (w/o square root extraction)

Pressure compensation (with square root extraction)

Addition / Subtraction

Multiplication

Division

Signal Selector Functions:

High selector

Low selector

RELATED PRODUCTS

- PC configurator software (model: M6CFG)

Downloadable at our web site.

A dedicated cable is required to connect the module to the PC. Please refer to the internet software download site or the users manual for the PC configurator for applicable cable types.

GENERAL SPECIFICATIONS

Connection

Input and output: Tension clamp

Power input: Via the Installation Base (model: M6SBS) or Tension clamp

Applicable wire size: 0.2 to 2.5 mm², stripped length 8 mm

Housing material: Flame-resistant resin (black)

Isolation: Input 1 or input 2 to output to power (Negative sides of the input 1 and 2 must be of the same potential.)

Overrange output: -2 - +102 %

(Negative current output is not available.)

Zero adjustment: -2 to +2 % (PC programming)

Span adjustment: 98 to 102 % (PC programming)

Power indicator LED: Green LED turns on when the power is supplied.

Status indicator LED: Orange LED; Blinking patterns indicate different operating status of the transmitter.

Programming: Downloaded from PC; input type and range, output type and range, zero and span, function type and parameters, etc.

For detailed information, refer to the users manual for the PC configurator.

Configurator connection: 2.5 dia. miniature jack; RS-232-C level

INPUT SPECIFICATIONS

■ **DC Current:** Input resistor incorporated

(If not specified, the input range is 4 - 20 mA DC.)

Input range: 0 - 50 mA DC

Minimum span: 2 mA

Offset: Lower range can be any specific value within the input range provided that the minimum span is maintained.

■ **DC Voltage**

• **Code S1 (narrow spans)**

Input range: -1000 - +1000 mV DC

Minimum span: 100 mV

• **Code S2 (wide spans)**

Input range: -10 - +10 V DC

Minimum span: 1 V

Offset: Lower range can be any specific value within the input range provided that the minimum span is maintained.

If not specified, the input range is shown below.

S1: 0 - 100 mV DC

S2: 1 - 5 V DC

OUTPUT SPECIFICATIONS

■ **DC Current**

Output range: 0 - 20 mA DC

Conformance range: 0 - 20.4 mA DC

Minimum span: 1 mA

Offset: Lower range can be any specific value within the output range provided that the minimum span is maintained.

Load resistance: Output drive 11 V max.

(e.g. 4 - 20 mA: 550 Ω [11 V ÷ 20 mA])

If not specified, the output range is 4 - 20 mA DC.

■ **DC Voltage**

Code V2 (wide spans)

Output range: -10 - +10 V DC

Conformance range: -10.4 - +10.4 V DC

Minimum span: 1 V

Code V3 (narrow spans)

Output range: -5 - +5 V DC

Conformance range: -5.2 - +5.2 V DC

Minimum span: 0.5 V

Offset: Lower range can be any specific value within the output range provided that the minimum span is maintained.

Load resistance: Output drive 1 mA max.

(e.g. 1 - 5 V: 5000 Ω [5 V ÷ 1 mA])

If not specified, the output range is shown below.

V2: 0 - 10 V DC

V3: 1 - 5 V DC

INSTALLATION

Power consumption: Approx. 0.5 W

Operating temperature: -20 to +55°C (-4 to +131°F)

Operating humidity: 30 to 90 %RH (non-condensing)

Mounting: Installation Base (model: M6SBS) or DIN rail

Weight: 65 g (2.3 oz)

PERFORMANCE in percentage of span

Overall accuracy: Input accuracy + output accuracy

See CALCULATION EXAMPLES OF OVERALL ACURACY

• **Input accuracy*:** (% of max. input range)

-1000 - +1000 mV : ±0.05 %

-10 - +10 V : ±0.05 %

0 - 50 mA : ±0.1 %

• **Output accuracy**:** ±0.04% of max. output range

*Inversely proportional to the span.

For math functions, the input accuracy equals that of either input 1 or 2, whichever is greater, with the following parameter setting:

$K_1=K_2=1$, $A_2=0\%$, $X_2=100\%$ for temp./press. compensation

$K_0=0.5$, $K_1=K_2=1$, $A_0=A_1=A_2=0\%$ for four arithmetic functions

For selector functions, it equals that of the selected signal.

**Inversely proportional to the span.

Temp. coefficient: ±0.01 %/°C (±0.006 %/°F) of max. span

Response time: ≤ 0.5 sec. (0 - 90 %)

Line voltage effect: ±0.1 % over voltage range

Insulation resistance: $\geq 100 \text{ M}\Omega$ with 500 V DC

Dielectric strength: 2000 V AC @1 minute (input to output to power to ground)

CALCULATION EXAMPLES OF OVERALL ACCURACY

[Example] Function: Temperature compensation w/o square root extraction; $K_1=K_2=1$, $A_2=0\%$, $X_2=100\%$

Input 1: Type -10 - +10 V / range 1 - 5 V

Input 2: Type 0 - 50 mA / range 4 - 20 mA

Output: Type 0 - 20 mA / range 4 - 20 mA

Input 1 = Max. Input Range (20 V) \div Span (4 V) \times 0.05% = 0.25%

Input 2 = Max. Input Range (50 mA) \div Span (16 mA) \times 0.1% = 0.31%

Output = Max. Output Range (20 mA) \div Span (16 mA) \times 0.04% = 0.05%

Accuracy = 0.31% (input 2 > input 1) + 0.05% = 0.36%

STANDARDS & APPROVALS

EU conformity:

EMC Directive

EMI EN 61000-6-4

EMS EN 61000-6-2

RoHS Directive

EXTERNAL VIEW

FRONT VIEW (with the cover open)

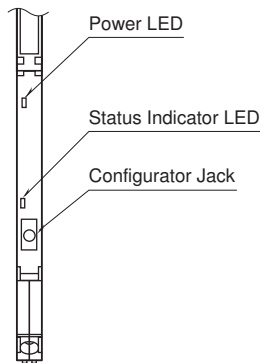

SIDE VIEW

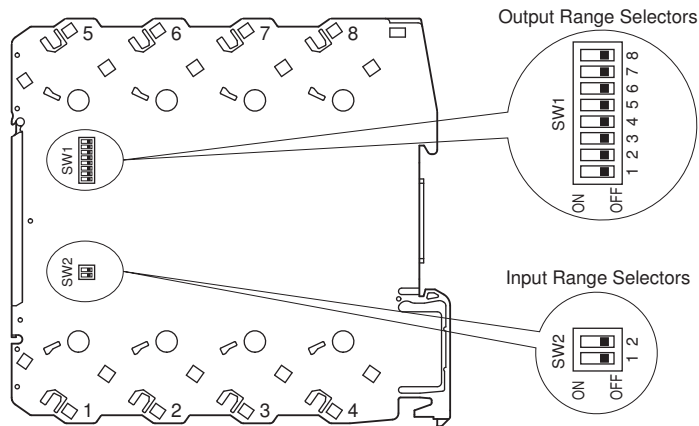

The DIP switch setting is required to select input and output types before setting a precise range using PC Configurator Software (model: M6CFG).

Refer to the instruction manual for detailed procedures.

EXTERNAL DIMENSIONS & TERMINAL ASSIGNMENTS unit: mm [inch]

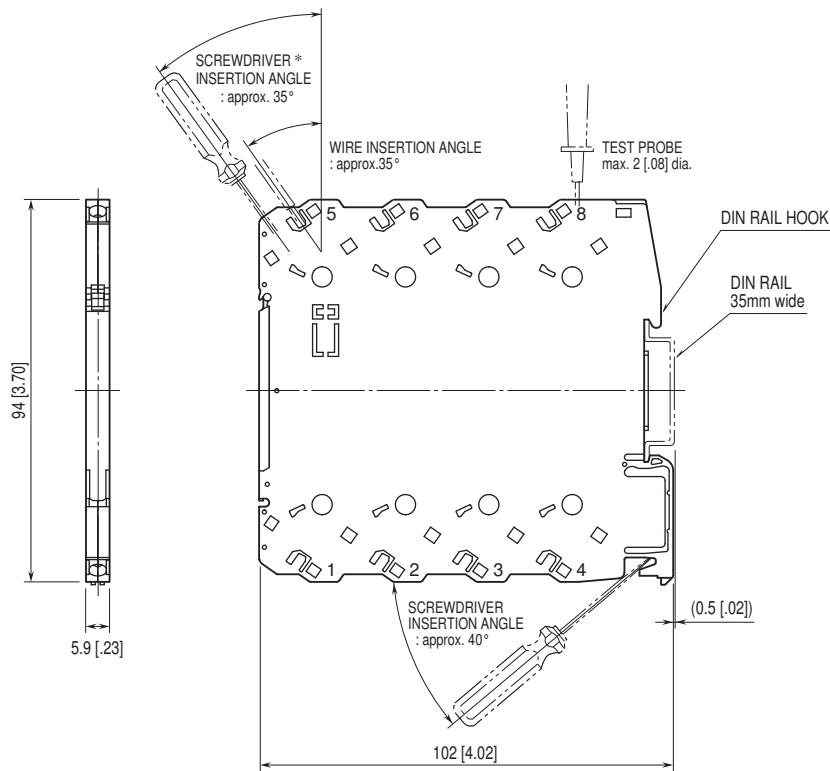

• When mounting, no extra space is needed between units.

*Use a minus screwdriver: tip width 3.8 mm max., tip thickness 0.5 to 0.6 mm

SCHEMATIC CIRCUITRY & CONNECTION DIAGRAM

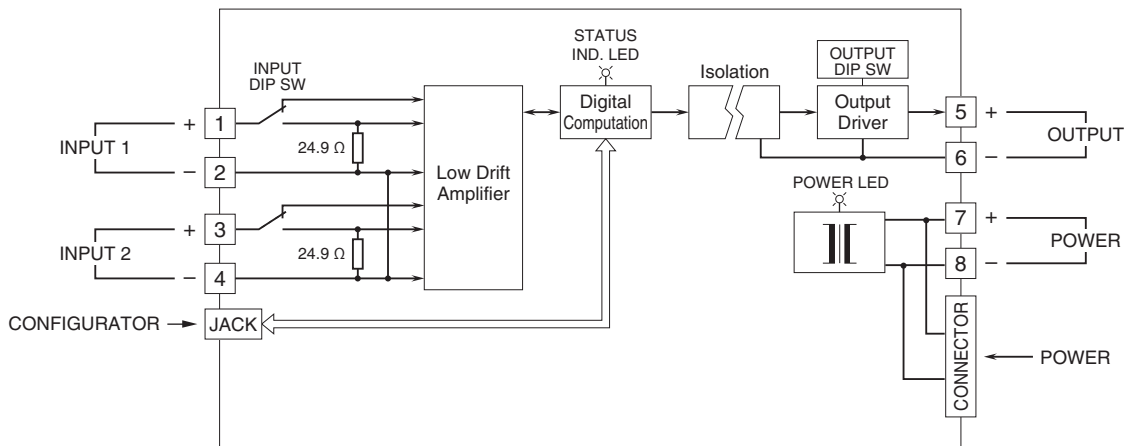

FUNCTIONS

■ FUNCTIONS

• Math Functions

Temperature compensation (w/o square root extraction)

$$X_0 = \frac{K_1 X_1}{\sqrt{K_2 X_2 + A_2}}$$

where X_0 : Compensated flow (linear characteristics)

X_1 : Uncompensated flow

X_2 : Temperature

Temperature compensation (with square root extraction)

$$X_0 = \frac{K_1 \sqrt{X_1}}{\sqrt{K_2 X_2 + A_2}}$$

where X_0 : Compensated flow (linear characteristics)

X_1 : Uncompensated flow

X_2 : Temperature

Pressure compensation (w/o square root extraction)

$$X_0 = K_1 X_1 \sqrt{K_2 X_2 + A_2}$$

where X_0 : Compensated flow (linear characteristics)

X_1 : Uncompensated flow

X_2 : Pressure

Pressure compensation (with square root extraction)

$$X_0 = K_1 \sqrt{X_1} \sqrt{K_2 X_2 + A_2}$$

where X_0 : Compensated flow (linear characteristics)

X_1 : Uncompensated flow

X_2 : Pressure

Addition / Subtraction

$$X_0 = K_0 \{K_1(X_1 + A_1) + K_2(X_2 + A_2)\} + A_0$$

Multiplication

$$X_0 = K_0(K_1 X_1 + A_1)(K_2 X_2 + A_2) + A_0$$

Division

$$X_0 = \frac{K_0(K_1 X_1 + A_1)}{(K_2 X_2 + A_2)} + A_0$$

• Signal Selector Functions

High selector

$$X_0 = X_1 \text{ with } X_1 \geq X_2$$

$$X_0 = X_2 \text{ with } X_1 < X_2$$

Low selector

$$X_0 = X_2 \text{ with } X_1 \geq X_2$$

$$X_0 = X_1 \text{ with } X_1 < X_2$$

Available range

X_0 : Output (%) -2 to +102%

X_1 through X_2 : Input (%) -2 to +102%

K_0 through K_2 : Gain (no unit) ± 29.999

A_0 through A_2 : Bias (%) $\pm 299.99\%$

Factory default setting: Addition / Subtraction

$K_0 = 1, K_1 = 1, K_2 = 1, A_0 = 0\%, A_1 = 0\%, A_2 = 0\%$



Specifications are subject to change without notice.