

Tension-Clamp Ultra-Slim Signal Conditioners M6S Series

HOLD FUNCTION MODULE

(PC programmable)

Functions & Features

- Maintenance-free tension clamp connection
- Track/Hold or Peak hold function's selection available
- 5.9-mm wide ultra-slim design with DC current signal input
- Low profile allows the M6S module to be mounted in a 120-mm deep panel
- PC programmable
- High-density mounting available
- Power and status indicator LEDs

Typical Applications

- Monitoring peak power consumption
- Monitoring the highest or lowest temperature
- Capturing signals from a composite analyzer performing on each sample in turn

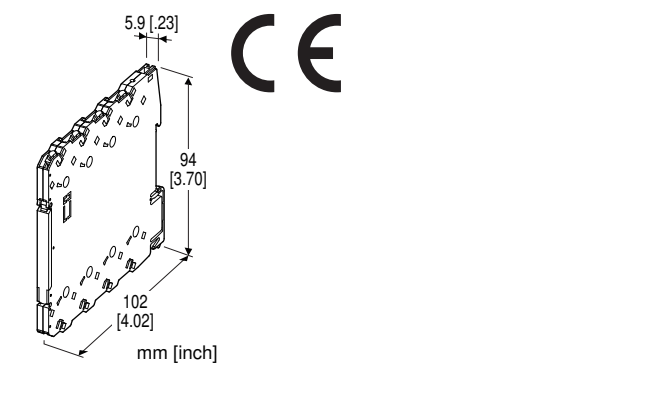

MODEL: M6SXF3-[1][2]-R[3]

ORDERING INFORMATION

- Code number: M6SXF3-[1][2]-R[3]
- Specify a code from below for each of [1] through [3].
(e.g. M6SXF3-Z1Z1-R/Q)
- Input range (e.g. 4 - 20 mA DC)
 - Output range (e.g. 4 - 20 mA DC)
 - Specify the specification for option code /Q (e.g. /C01)

[1] INPUT

Current

Z1: Range 0 - 50 mA DC (Input resistance 24.9 Ω)

Voltage

S1: Range -1000 - +1000 mV DC (Input resistance 1 MΩ min.)

S2: Range -10 - +10 V DC (Input resistance 1 MΩ min.)

(Configurator software is used to change input over the described range of the selected suffix code.

For changing between suffix codes, set the Input Range Selector on the side of unit before software adjustment.)

[2] OUTPUT

Current

Z1: Range 0 - 20 mA DC

Voltage

V2: Range -10 - +10 V DC

V3: Range -5 - +5 V DC

(Configurator software is used to change output over the described range of the selected suffix code.

For changing between suffix codes, set the Output Range Selector on the side of unit before software adjustment.)

POWER INPUT

DC Power

R: 24 V DC

(Operational voltage range 24 V ±10 %, ripple 10 %p-p max.)

[3] OPTIONS

blank: none

/Q: With options (specify the specification)

SPECIFICATIONS OF OPTION: Q

COATING (For the detail, refer to our web site.)

/C01: Silicone coating

/C02: Polyurethane coating

FUNCTIONS

PC Configurator Software is used to change function type.

- Track/Hold
- Peak hold

Peak hold

Valley hold

Peak-to-peak hold (Peak hold-Valley hold)

Factory default setting

Control/Hold: Track/Hold

Control/Control Logic: Hold at open

RELATED PRODUCTS

- PC configurator software (model: M6CFG)

Downloadable at our web site.

A dedicated cable is required to connect the module to the PC. Please refer to the internet software download site or the users manual for the PC configurator for applicable cable types.

GENERAL SPECIFICATIONS

Connection

Input and output: Tension clamp

Power input: Via the Installation Base (model: M6SBS) or Tension clamp

Applicable wire size: 0.2 to 2.5 mm², stripped length 8 mm

Housing material: Flame-resistant resin (black)

Isolation: Input to output to power

Overrange output: -2 - +102 %

(Negative current output is not available.)

Zero adjustment: -2 to +2 % (PC programming)

Span adjustment: 98 to 102 % (PC programming)

Power indicator LED: Green LED turns on when the power is supplied.

Status indicator LED: Orange LED; Blinking patterns indicate different operating status of the transmitter.

Programming: Downloaded from PC; input type and range, output type and range, zero and span, function type, control input logic, user's linearization table (max. 101 points, specified within -2 to +102% for both input and output), etc. For detailed information, refer to the users manual for the PC configurator.

Configurator connection: 2.5 dia. miniature jack; RS-232-C level

INPUT SPECIFICATIONS

■ **DC Current:** Input resistor incorporated

(If not specified, the input range is 4 - 20 mA DC.)

Input range: 0 - 50 mA DC

Minimum span: 2 mA

Offset: Lower range can be any specific value within the input range provided that the minimum span is maintained.

■ **DC Voltage**

• **Code S1 (narrow spans)**

Input range: -1000 - +1000 mV DC

Minimum span: 100 mV

• **Code S2 (wide spans)**

Input range: -10 - +10 V DC

Minimum span: 1 V

Offset: Lower range can be any specific value within the input range provided that the minimum span is maintained. If not specified, the input range is shown below.

S1: 0 - 100 mV DC

S2: 1 - 5 V DC

• **Control**

Contact rating: 3 V @1 mA

Detection levels:

≤ 0.6 kΩ / 0.5 V at close

≥ 15 kΩ / 2.5 V at open

OUTPUT SPECIFICATIONS

■ **DC Current**

Output range: 0 - 20 mA DC

Conformance range: 0 - 20.4 mA DC

Minimum span: 1 mA

Offset: Lower range can be any specific value within the output range provided that the minimum span is maintained.

Load resistance: Output drive 11 V max.

(e.g. 4 - 20 mA: 550 Ω [11 V ÷ 20 mA])

If not specified, the output range is 4 - 20 mA DC.

■ **DC Voltage**

Code V2 (wide spans)

Output range: -10 - +10 V DC

Conformance range: -10.4 - +10.4 V DC

Minimum span: 1 V

Code V3 (narrow spans)

Output range: -5 - +5 V DC

Conformance range: -5.2 - +5.2 V DC

Minimum span: 0.5 V

Offset: Lower range can be any specific value within the output range provided that the minimum span is maintained.

Load resistance: Output drive 1 mA max.

(e.g. 1 - 5 V: 5000 Ω [5 V ÷ 1 mA])

If not specified, the output range is shown below.

V2: 0 - 10 V DC

V3: 1 - 5 V DC

INSTALLATION

Power consumption: Approx. 0.5 W

Operating temperature: -20 to +55°C (-4 to +131°F)

Operating humidity: 30 to 90 %RH (non-condensing)

Mounting: Installation Base (model: M6SBS) or DIN rail

Weight: 65 g (2.3 oz)

PERFORMANCE in percentage of span

Overall accuracy: Input accuracy + output accuracy
Inversely proportional to the span.

See CALCULATION EXAMPLES OF OVERALL ACURACY.

• **Input accuracy:** (% of max. input range)

-1000 - +1000 mV : ±0.01 %

-10 - +10 V : ±0.01 %

0 - 50 mA : ±0.02 %

• **Output accuracy:** ±0.04 % of max. output range

Temp. coefficient: ±0.01 %/°C (±0.006 %/°F) of max. span

Response time: ≤ 0.5 sec. (0 - 90 %)

Line voltage effect: ±0.1 % over voltage range

Insulation resistance: ≥ 100 MΩ with 500 V DC

Dielectric strength: 2000 V AC @1 minute (input to output to power to ground)

CALCULATION EXAMPLES OF OVERALL ACCURACY

[Example] Input Type -10 - +10 V, Input Range 1 - 5 V,

Output Type -5 - +5 V, Output Range 1 - 5 V

• Input accuracy = Max. Input Range (20 V) ÷ Span (4 V) × 0.01 % = 0.05 %

• Output accuracy = Max. Output Range (10 V) ÷ Span (4 V) × 0.04 % = 0.1 %

Accuracy = ±0.15 %

STANDARDS & APPROVALS

EU conformity:

EMC Directive

EMI EN 61000-6-4

EMS EN 61000-6-2

RoHS Directive

EXTERNAL VIEW

FRONT VIEW (with the cover open)

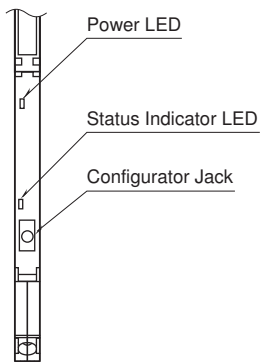

SIDE VIEW

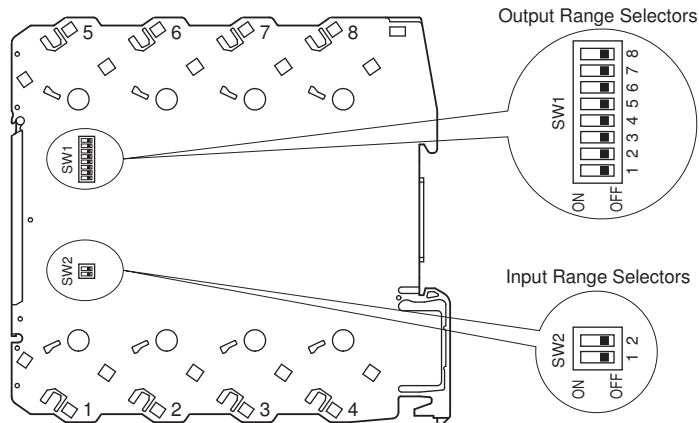

The DIP switch setting is required to select input and output types before setting a precise range using PC Configurator Software (model: M6CFG).

Refer to the instruction manual for detailed procedures.

EXTERNAL DIMENSIONS & TERMINAL ASSIGNMENTS unit: mm [inch]

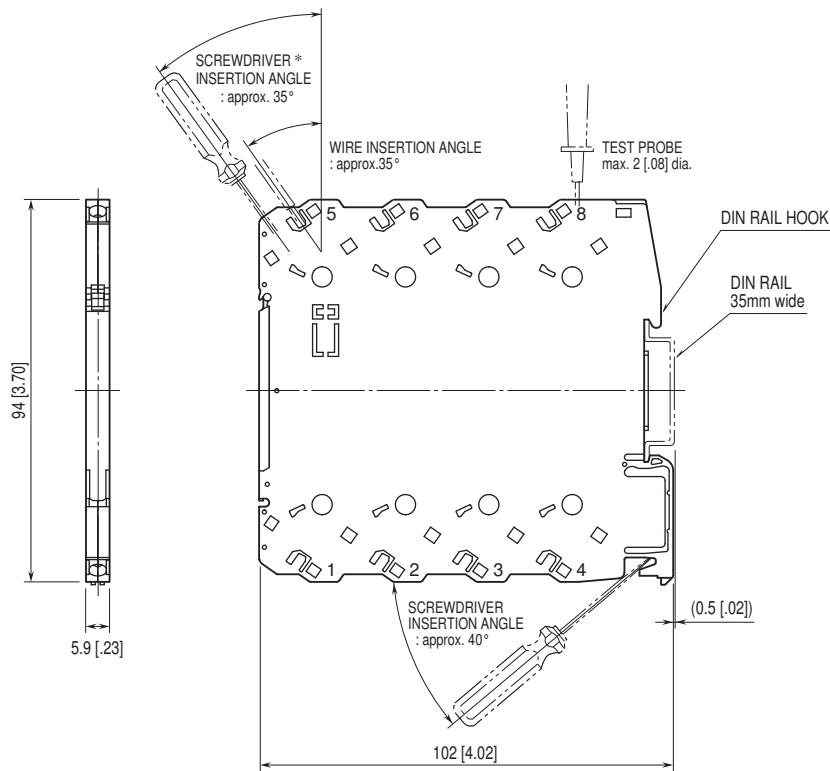

• When mounting, no extra space is needed between units.

*Use a minus screwdriver: tip width 3.8 mm max., tip thickness 0.5 to 0.6 mm

SCHEMATIC CIRCUITRY & CONNECTION DIAGRAM

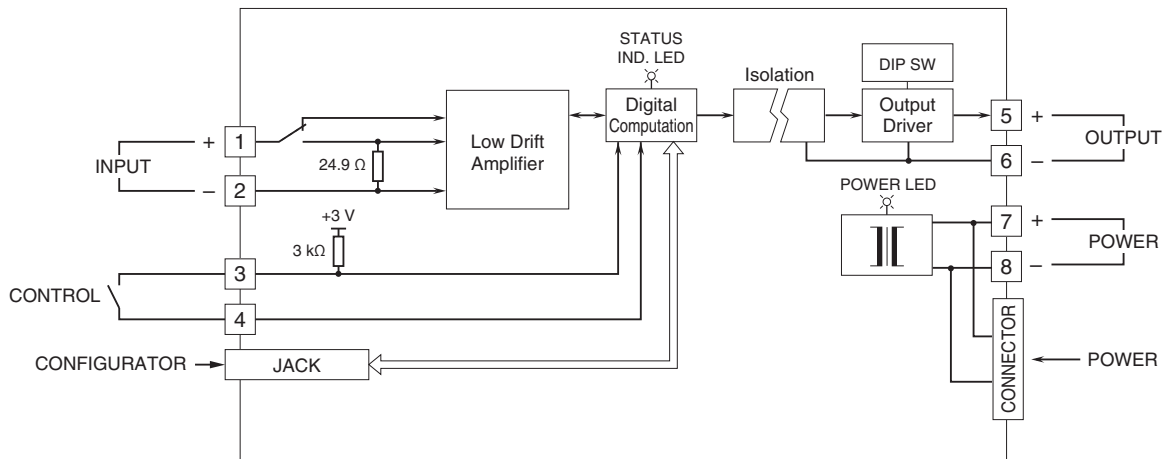

FUNCTIONS

■ CONTROL LOGIC

The control input can be chosen either hold at open or hold at close by using the PC Configurator Software.
For detailed information on the PC Configuration, refer to the M6CFG users manual.

■ TRACK/HOLD

When the control input is TRACK, the output follows proportionally to the input.
When the control input turns to HOLD, the output at the point of command is held indefinitely.

■ PEAK HOLD

• Peak hold

When the control input is TRACK, the output follows proportionally to the input.
When the control input is HOLD, the output is held at the maximum input value.
When the maximum input value is updated, the output changes to that value.

• Valley hold

When the control input is TRACK, the output follows proportionally to the input.
When the control input is HOLD, the output is held at the minimum input value.
When the minimum input value is updated, the output changes to that value.

• Peak-to-peak hold

When the control input is TRACK, the output follows proportionally to the input.
When the control input is HOLD, the output is held at the maximum peak-to-peak input value (max. value - min. value).
For example, the output is 20% if the maximum input value is 60% and the minimum input value is 40%.
When the maximum peak-to-peak input value is updated, the output changes to that value.



Specifications are subject to change without notice.