

Plug-in Signal Conditioners M-UNIT

OPTICAL TRANSMITTER

Functions & Features

- Isolation up to several hundred thousand volts with a fiber optics cable
- High-density mounting

Typical Applications

- Ion implanter
- Electron-beam devices
- Dust chamber
- Protection against inductive noises in power substations

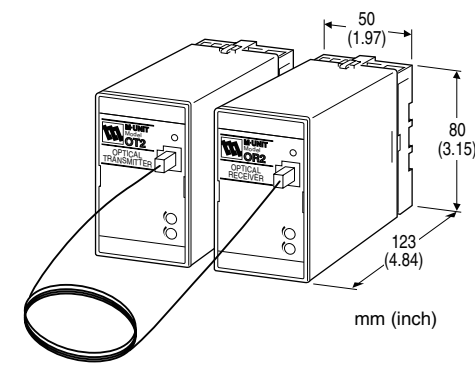

MODEL: OT2-[1]-[2][3]

ORDERING INFORMATION

- Code number: OT2-[1]-[2][3]
- Specify a code from below for each of [1] through [3].
(e.g. OT2-6-B/Q)
- Special input range (For codes Z & 0)
- Specify the specification for option code /Q
(e.g. /C01/S01)

[1] INPUT

Current

- A:** 4 - 20 mA DC (Input resistance 250 Ω)
- A1:** 4 - 20 mA DC (Input resistance 50 Ω)
- B:** 2 - 10 mA DC (Input resistance 500 Ω)
- C:** 1 - 5 mA DC (Input resistance 1000 Ω)
- D:** 0 - 20 mA DC (Input resistance 50 Ω)
- E:** 0 - 16 mA DC (Input resistance 62.5 Ω)
- F:** 0 - 10 mA DC (Input resistance 100 Ω)
- G:** 0 - 1 mA DC (Input resistance 1000 Ω)
- H:** 10 - 50 mA DC (Input resistance 100 Ω)
- Z:** Specify current (See INPUT SPECIFICATIONS)

Voltage

- 1:** 0 - 10 mV DC (Input resistance 10 kΩ min.)

- 2:** 0 - 100 mV DC (Input resistance 100 kΩ min.)
- 3:** 0 - 1 V DC (Input resistance 1 MΩ min.)
- 4:** 0 - 10 V DC (Input resistance 1 MΩ min.)
- 5:** 0 - 5 V DC (Input resistance 1 MΩ min.)
- 6:** 1 - 5 V DC (Input resistance 1 MΩ min.)
- 4W:** -10 - +10 V DC (Input resistance 1 MΩ min.)
- 0:** Specify voltage (See INPUT SPECIFICATIONS)

[2] POWER INPUT

AC Power

- B:** 100 V AC
 - C:** 110 V AC
 - D:** 115 V AC
 - F:** 120 V AC
 - G:** 200 V AC
 - H:** 220 V AC
 - J:** 240 V AC
- ##### DC Power
- S:** 12 V DC
 - R:** 24 V DC

[3] OPTIONS

blank: none

/Q: With options (specify the specification)

SPECIFICATIONS OF OPTION: Q (multiple selections)

COATING (For the detail, refer to our web site.)

- /C01:** Silicone coating
 - /C02:** Polyurethane coating
 - /C03:** Rubber coating
- TERMINAL SCREW MATERIAL
- /S01:** Stainless steel

RELATED PRODUCTS

- Optical receiver (Model: OR2)
- Fiber optics cable:
 - 10 meters (model: AMPCP2-10M)
 - 20 meters (model: AMPCP2-20M)
 - 30 meters (model: AMPCP2-30M)
- Optical cable used for the AMPCP2
 - Mitsubishi Chemical Super Eska SH 4001
 - Minimum bend radius: 25 mm
 - Tension strength: ≤ 70 N
- Connector used for the AMPCP2
 - Broadcom HFBR-4532Z

GENERAL SPECIFICATIONS

Construction: Plug-in

Transmission method: Light pulse (100 - 500 Hz)

Maximum transmission distance: 30 meters (98 ft)

Connection

Input & power input: M3.5 screw terminals

Optical fiber: Connector

Screw terminal: Chromated steel (standard) or stainless steel

Housing material: Flame-resistant resin (black)

Isolation: Input to power

Zero adjustment: -5 to +5 % (front)

Span adjustment: 95 to 105 % (front)

Power indicator LED: Green LED turns on when the power is supplied.

INPUT SPECIFICATIONS

■ **DC Current:**

Shunt resistor attached to the input terminals (0.5 W)

Specify input resistance value for code Z.

■ **DC Voltage:** -300 - +300 V DC

Minimum span: 10 mV

Offset: Max. 1.5 times span

Input resistance

Span 10 - 100 mV : $\geq 10 \text{ k}\Omega$

Span 0.1 - 1 V : $\geq 100 \text{ k}\Omega$

Span $\geq 1 \text{ V}$: $\geq 1 \text{ M}\Omega$

INSTALLATION

Power input

•**AC:** Operational voltage range: rating $\pm 10 \%$,

50/60 ± 2 Hz, approx. 3 VA

•**DC:** Operational voltage range: rating $\pm 10 \%$,

ripple 10 %p-p max., approx. 2 W (80 mA at 24 V)

Operating temperature: -5 to +60°C (23 to 140°F)

Operating humidity: 30 to 90 %RH (non-condensing)

Mounting: Surface or DIN rail

Weight: 400 g (0.88 lb)

PERFORMANCE in percentage of span

Accuracy: $\pm 0.3 \%$ (Overall performance with the OT2 and OR2 combined)

Temp. coefficient: $\pm 0.015 \%/^{\circ}\text{C}$ ($\pm 0.008 \%/^{\circ}\text{F}$)

Response time: ≤ 0.6 second (0 - 90 %) (Overall performance with the OT2 and OR2 combined)

Line voltage effect: $\pm 0.1 \%$ over voltage range

Insulation resistance: $\geq 100 \text{ M}\Omega$ with 500 V DC

Dielectric strength: 2000 V AC @ 1 minute

(input to power to ground)

EXTERNAL VIEW

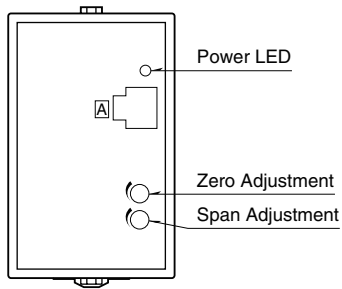

EXTERNAL DIMENSIONS unit: mm [inch]

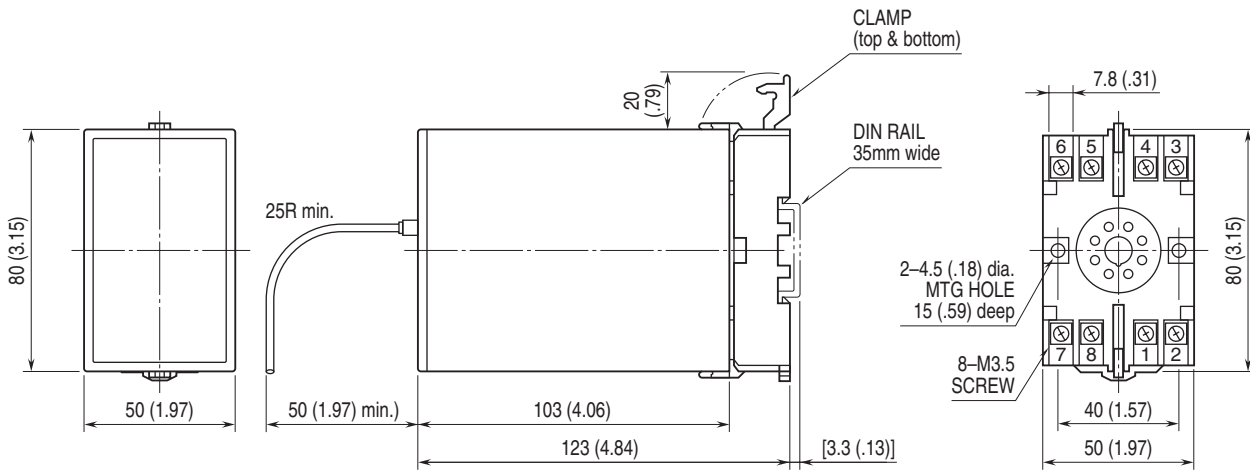

• When mounting, no extra space is needed between units.

TERMINAL ASSIGNMENTS unit: mm [inch]

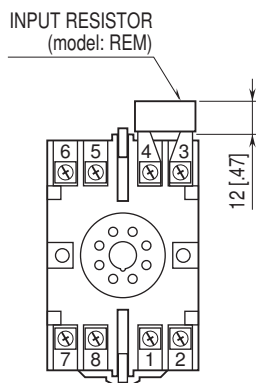

Input shunt resistor attached for current input.

SCHEMATIC CIRCUITRY & CONNECTION DIAGRAM

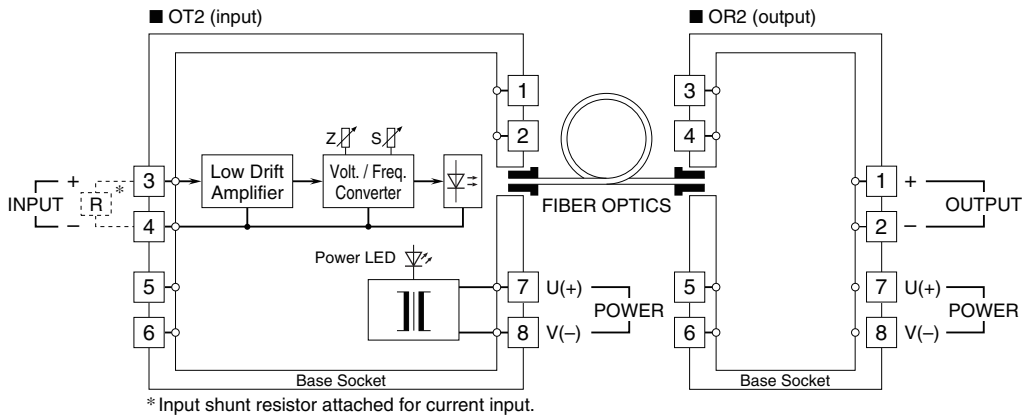

Specifications are subject to change without notice.