

Plug-in Signal Conditioners M-UNIT

PEAK HOLD

(non-isolated)

Functions & Features

- Track mode: the output follows proportionally to the input
- Peak-hold mode: responds only to an increasing signal, holding the maximum value until a higher signal or a command to reset is received
- Minimum value (valley) hold selectable
- LCD meter
- High-density mounting

Typical Applications

- Monitoring peak power consumption
- Monitoring the highest or lowest temperature

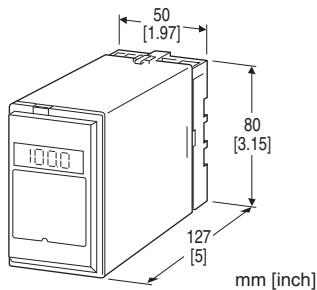

MODEL: PH[1]-[2][3]-[4][5]

ORDERING INFORMATION

- Code number: PH[1]-[2][3]-[4][5]
- Specify a code from below for each of [1] through [5].
(e.g. PHH-6A-B/E/Q)
- Special input and output ranges (For codes Z & 0)
- Specify the specification for option code /Q
(e.g. /C01/S01)

[1] HOLD FUNCTION

- H: Peak hold
- L: Valley hold

[2] INPUT

Current

- A: 4 - 20 mA DC (Input resistance 250 Ω)
- A1: 4 - 20 mA DC (Input resistance 50 Ω)
- B: 2 - 10 mA DC (Input resistance 500 Ω)
- C: 1 - 5 mA DC (Input resistance 1000 Ω)
- D: 0 - 20 mA DC (Input resistance 50 Ω)
- E: 0 - 16 mA DC (Input resistance 62.5 Ω)
- F: 0 - 10 mA DC (Input resistance 100 Ω)

- G: 0 - 1 mA DC (Input resistance 1000 Ω)
 - H: 10 - 50 mA DC (Input resistance 100 Ω)
 - J: 0 - 10 μA DC (Input resistance 1000 Ω)
 - K: 0 - 100 μA DC (Input resistance 1000 Ω)
 - GW: -1 - +1 mA DC (Input resistance 1000 Ω)
 - FW: -10 - +10 mA DC (Input resistance 100 Ω)
 - Z: Specify current (See INPUT SPECIFICATIONS)
- Voltage
- 1: 0 - 10 mV DC (Input resistance 10 kΩ min.)
 - 15: 0 - 50 mV DC (Input resistance 10 kΩ min.)
 - 16: 0 - 60 mV DC (Input resistance 10 kΩ min.)
 - 2: 0 - 100 mV DC (Input resistance 100 kΩ min.)
 - 3: 0 - 1 V DC (Input resistance 1 MΩ min.)
 - 4: 0 - 10 V DC (Input resistance 1 MΩ min.)
 - 5: 0 - 5 V DC (Input resistance 1 MΩ min.)
 - 6: 1 - 5 V DC (Input resistance 1 MΩ min.)
 - 4W: -10 - +10 V DC (Input resistance 1 MΩ min.)
 - 5W: -5 - +5 V DC (Input resistance 1 MΩ min.)
 - 0: Specify voltage (See INPUT SPECIFICATIONS)

[3] OUTPUT

Current

- A: 4 - 20 mA DC (Load resistance 750 Ω max.)
- B: 2 - 10 mA DC (Load resistance 1500 Ω max.)
- C: 1 - 5 mA DC (Load resistance 3000 Ω max.)
- D: 0 - 20 mA DC (Load resistance 750 Ω max.)
- E: 0 - 16 mA DC (Load resistance 900 Ω max.)
- F: 0 - 10 mA DC (Load resistance 1500 Ω max.)
- G: 0 - 1 mA DC (Load resistance 15 kΩ max.)
- Z: Specify current (See OUTPUT SPECIFICATIONS)

Voltage

- 1: 0 - 10 mV DC (Load resistance 10 kΩ min.)
- 2: 0 - 100 mV DC (Load resistance 100 kΩ min.)
- 3: 0 - 1 V DC (Load resistance 100 Ω min.)
- 4: 0 - 10 V DC (Load resistance 1000 Ω min.)
- 5: 0 - 5 V DC (Load resistance 500 Ω min.)
- 6: 1 - 5 V DC (Load resistance 500 Ω min.)
- 4W: -10 - +10 V DC (Load resistance 2000 Ω min.)
- 5W: -5 - +5 V DC (Load resistance 1000 Ω min.)
- 0: Specify voltage (See OUTPUT SPECIFICATIONS)

[4] POWER INPUT

AC Power
B: 100 V AC
C: 110 V AC
D: 115 V AC
F: 120 V AC
G: 200 V AC
H: 220 V AC
J: 240 V AC
 DC Power
S: 12 V DC
R: 24 V DC
V: 48 V DC
P: 110 V DC

[5] OPTIONS (multiple selections)

LCD Meter (for indicating value being held)

blank: Without

/E: With (0.0 - 100.0 % display)

Other Options

blank: none

/Q: Option other than the above (specify the specification)

SPECIFICATIONS OF OPTION: Q (multiple selections)

COATING (For the detail, refer to our web site.)

/C01: Silicone coating

/C02: Polyurethane coating

/C03: Rubber coating

TERMINAL SCREW MATERIAL

/S01: Stainless steel

GENERAL SPECIFICATIONS

Construction: Plug-in

Connection: M3.5 screw terminals

Screw terminal: Chromated steel (standard) or stainless steel

Housing material: Flame-resistant resin (black)

Isolation: Input or output to power

Overrange output: Approx. -10 to +120 % at 1 - 5 V

Zero adjustment: -5 to +5 % (front)

Span adjustment: 95 to 105 % (front)

Hold control: Holds when opening the terminals 5 - 6; tracks when closing them

■ **DISPLAY (LCD meter)**

• **Option code:** /E

LCD digital display: 0.0 - 100.0 % (min. digit 0.1 %)
 (No scaling)

INPUT SPECIFICATIONS

■ **DC Current:**

Shunt resistor attached to the input terminals (0.5 W)

Specify input resistance value for code Z.

■ **DC Voltage:** -300 - +300 V DC

Minimum span: 3 mV

Offset: Max. 1.5 times span

Input resistance

Span 3 - 10 mV : $\geq 10 \text{ k}\Omega$

Span 10 - 100 mV : $\geq 10 \text{ k}\Omega$

Span 0.1 - 1 V : $\geq 100 \text{ k}\Omega$

Span $\geq 1 \text{ V}$: $\geq 1 \text{ M}\Omega$

■ **HOLD CONTROL**

Contact rating: 5 V @1 mA

Detection levels: $\leq 1.25 \text{ k}\Omega$ / 1 V at Track

$\geq 20 \text{ k}\Omega$ / 4 V at Hold

OUTPUT SPECIFICATIONS

■ **DC Current:** 0 - 20 mA DC

Minimum span: 1 mA

Offset: Max. 1.5 times span

Load resistance: Output drive 15 V max.

■ **DC Voltage:** -10 - +12 V DC

Minimum span: 5 mV

Offset: Max. 1.5 times span

Load resistance: Output drive 10 mA max.; 5 mA for negative voltage output; at $\geq 0.5 \text{ V}$

INSTALLATION

Power input

• **AC:** Operational voltage range: rating $\pm 10 \%$,

50/60 ± 2 Hz, approx. 2 VA

• **DC:** Operational voltage range: rating $\pm 10 \%$, or 85 - 150 V for 110 V rating (ripple 10 % p-p max.) approx. 2 W (90 mA at 24 V)

Operating temperature: -5 to +60°C (23 to 140°F)

Operating humidity: 30 to 90 %RH (non-condensing)

Mounting: Surface or DIN rail

Weight: 400 g (0.88 lb)

PERFORMANCE in percentage of span

Accuracy: $\pm 0.2 \%$

Display accuracy: $\pm (0.2 \%$ of FS + 1 digit)

Temp. coefficient: $\pm 0.015 \%$ /°C ($\pm 0.008 \%$ /°F)

Response time: $\leq 0.5 \text{ sec.}$ (0 - 90 %)

Line voltage effect: $\pm 0.1 \%$ over voltage range

Insulation resistance: $\geq 100 \text{ M}\Omega$ with 500 V DC

Dielectric strength: 2000 V AC @1 minute (input or output to power to ground)

EXTERNAL DIMENSIONS unit: mm [inch]

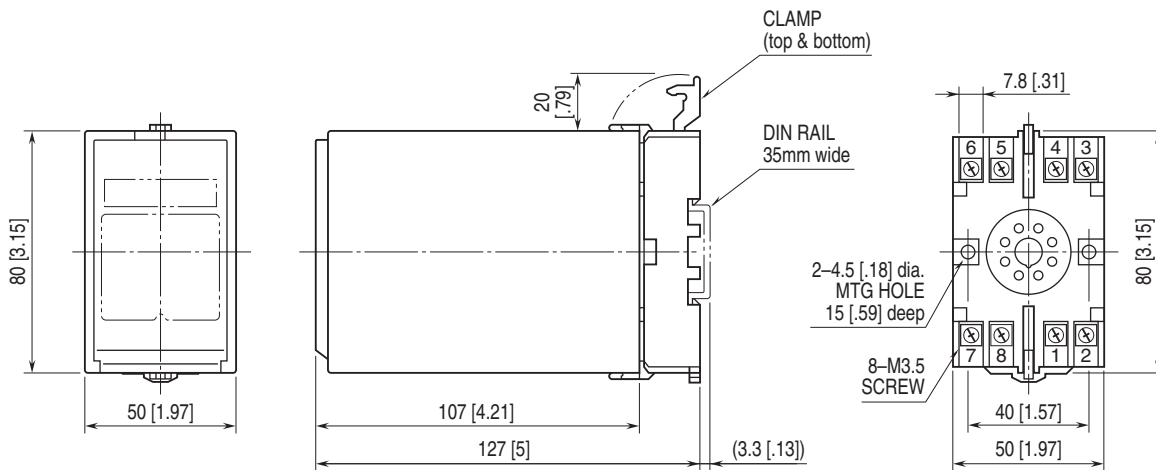

• When mounting, no extra space is needed between units.

TERMINAL ASSIGNMENTS unit: mm [inch]

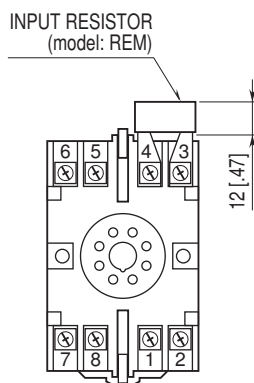

Input shunt resistor attached for current input.

SCHEMATIC CIRCUITRY & CONNECTION DIAGRAM

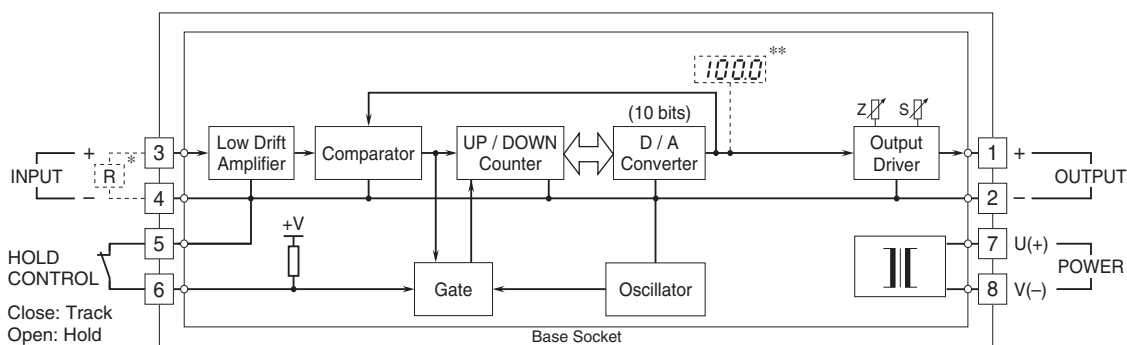

* Input shunt resistor attached for current input.

** Option /E



Specifications are subject to change without notice.