

Plug-in Signal Conditioners M-UNIT

RTD TRANSMITTER

(non-isolated)

Functions & Features

- Accepting direct input from an RTD and providing a standard process signal
- Linearization
- Burnout protection
- "Active bridge" circuit containing two constant current sources allows large leadwire resistances up to 200 Ω
- LCD meter (engineering unit display selectable)
- Simple loop test output (0 % and 100 %)
- High-density mounting

Typical Applications

- Long distance transmission between the RTD and the transmitter
- Combination with intrinsic safety barriers

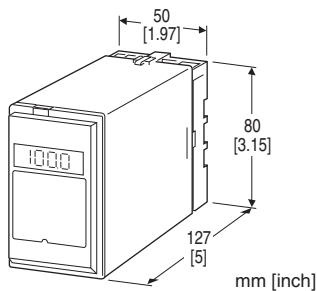

MODEL: RB-[1][2]-[3][4]

ORDERING INFORMATION

- Code number: RB-[1][2]-[3][4]
- Specify a code from below for each of [1] through [4].
(e.g. RB-1A-B/E2/BL/Q)
- Temperature range (e.g. 0 - 500°C)
 - Special output range (For codes Z & 0)
 - Specify the specification for option code /Q
(e.g. /C01/S01)

[1] INPUT RTD (2- or 3-wire)

- 1:** JPt 100 (JIS'89)
(Usable range: -200 to +500°C, -328 to +932°F; min.span: 50°C, 90°F)
- 3:** Pt 100 (JIS'89)
(Usable range: -200 to +650°C, -328 to +1202°F; min.span: 50°C, 90°F)
- 4:** Pt 100 (JIS'97, IEC)
(Usable range: -200 to +650°C, -328 to +1202°F; min.span: 50°C, 90°F)
- 5:** Pt 50 Ω (JIS'81)
(Usable range: -200 to +500°C, -328 to +932°F; min.span: 100°C, 180°F)

6: Ni 508.4 Ω

(Usable range: -50 to +200°C, -58 to +392°F; min.span: 30°C, 54°F)

0: Specify

Note: Consult us for 2-wire RTD

[2] OUTPUT

Current

- A:** 4 - 20 mA DC (Load resistance 750 Ω max.)
B: 2 - 10 mA DC (Load resistance 1500 Ω max.)
C: 1 - 5 mA DC (Load resistance 3000 Ω max.)
D: 0 - 20 mA DC (Load resistance 750 Ω max.)
E: 0 - 16 mA DC (Load resistance 900 Ω max.)
F: 0 - 10 mA DC (Load resistance 1500 Ω max.)
G: 0 - 1 mA DC (Load resistance 15 kΩ max.)
Z: Specify current (See OUTPUT SPECIFICATIONS)

Voltage

- 1:** 0 - 10 mV DC (Load resistance 10 kΩ min.)
2: 0 - 100 mV DC (Load resistance 100 kΩ min.)
3: 0 - 1 V DC (Load resistance 100 Ω min.)
4: 0 - 10 V DC (Load resistance 1000 Ω min.)
5: 0 - 5 V DC (Load resistance 500 Ω min.)
6: 1 - 5 V DC (Load resistance 500 Ω min.)
0: Specify voltage (See OUTPUT SPECIFICATIONS)

[3] POWER INPUT

AC Power

- B:** 100 V AC
C: 110 V AC
D: 115 V AC
F: 120 V AC
G: 200 V AC
H: 220 V AC
J: 240 V AC

DC Power

- S:** 12 V DC
R: 24 V DC
V: 48 V DC
P: 110 V DC (Not selectable with Option /E2)

[4] OPTIONS (multiple selections)

Input Signal Indicator

blank: Without

/E: With (0.0 - 100.0 % display)

/E2: With (in engineering unit with backlight and the simple loop test output)

Burnout

blank: Upscale burnout

/BL: Downscale burnout

Other Options

blank: none

/Q: Option other than the above (specify the specification)

SPECIFICATIONS OF OPTION: Q (multiple selections)

COATING (For the detail, refer to our web site.)

/C01: Silicone coating

/C02: Polyurethane coating

/C03: Rubber coating

TERMINAL SCREW MATERIAL

/S01: Stainless steel

GENERAL SPECIFICATIONS

Construction: Plug-in

Connection: M3.5 screw terminals

Screw terminal: Chromated steel (standard) or stainless steel

Housing material: Flame-resistant resin (black)

Isolation: Input or output to power

Overrange output: Approx. -10 to +120 % at 1 - 5 V

Zero adjustment: -5 to +5 % (front)

Span adjustment: 95 to 105 % (front)

At burnout: Downscale \leq -10 %, Upscale \geq 110 %
(When the offset is negative, downscale \leq -8 %, upscale \geq 108 %.)

Linearization: Standard

Simple loop test output: 0 % and 100 % signal simulated by selecting the front switch positions. (Only for option code /E2)

■ **DISPLAY (Input indicator)**

- **Option code:** /E

LCD digital display: 0.0 - 100.0 % (min. digit 0.1 %)
(No scaling)

- **Option code:** /E2

LCD digital display: Engineering unit

Display scaling: -10000 - +10000

Decimal position: 10^{-1} - 10^{-4} or no decimal point

Engineering unit: %, μ V, mV, V, mA, A, °C, °F, Ω , DEG K, mHz, Hz, kHz, VAC, AAC, mg, g, kg, t, rpm or rps selectable

Back light: Green at normal, red at loop test output enable

Factory setting: scaling 0.00 - 100.00, unit: %

INPUT SPECIFICATIONS

Maximum leadwire resistance: 200 Ω per wire (3-wire)

Sensing current: 2 mA

OUTPUT SPECIFICATIONS

■ **DC Current:** 0 - 20 mA DC

Minimum span: 1 mA

Offset: Max. 1.5 times span

Load resistance: Output drive 15 V max.

■ **DC Voltage:** -10 - +12 V DC

Minimum span: 5 mV

Offset: Max. 1.5 times span

Load resistance: Output drive 10 mA max.; 5 mA for

negative voltage output; at \geq 0.5 V

INSTALLATION**Power input**

• **AC:** Operational voltage range: rating \pm 10 %, 50/60 \pm 2 Hz, approx. 2 VA

(approx. 3 VA with Option /E2)

• **DC:** Operational voltage range: rating \pm 10 %, or 85 - 150 V for 110 V rating (ripple 10 % p-p max.) approx. 2 W (80 mA at 24 V; approx. 3 W with Option /E2)

Operating temperature: -5 to +60°C (23 to 140°F)

Operating humidity: 30 to 90 %RH (non-condensing)

Mounting: Surface or DIN rail

Weight: 350 g (0.77 lb)

PERFORMANCE in percentage of span

Accuracy: \pm 0.2 %

Display accuracy: \pm (0.2 % of FS + 1 digit)

Simple loop test output setting accuracy: \pm 0.5 %

Temp. coefficient: \pm 0.015 %/°C (\pm 0.008 %/°F)

Response time: \leq 0.5 sec. (0 - 90 %)

Burnout response: \leq 10 sec.

Line voltage effect: \pm 0.1 % over voltage range

Insulation resistance: \geq 100 M Ω with 500 V DC

Dielectric strength: 2000 V AC @1 minute (input or output to power to ground)

EXTERNAL VIEW

■ OPTION /E

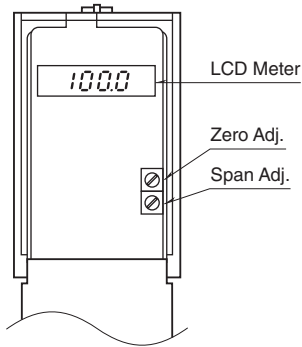

■ OPTION /E2

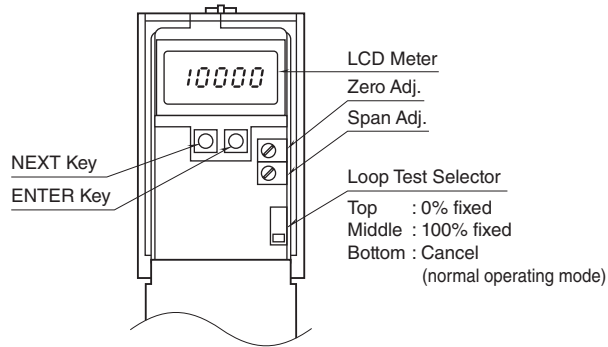

EXTERNAL DIMENSIONS & TERMINAL ASSIGNMENTS unit: mm [inch]

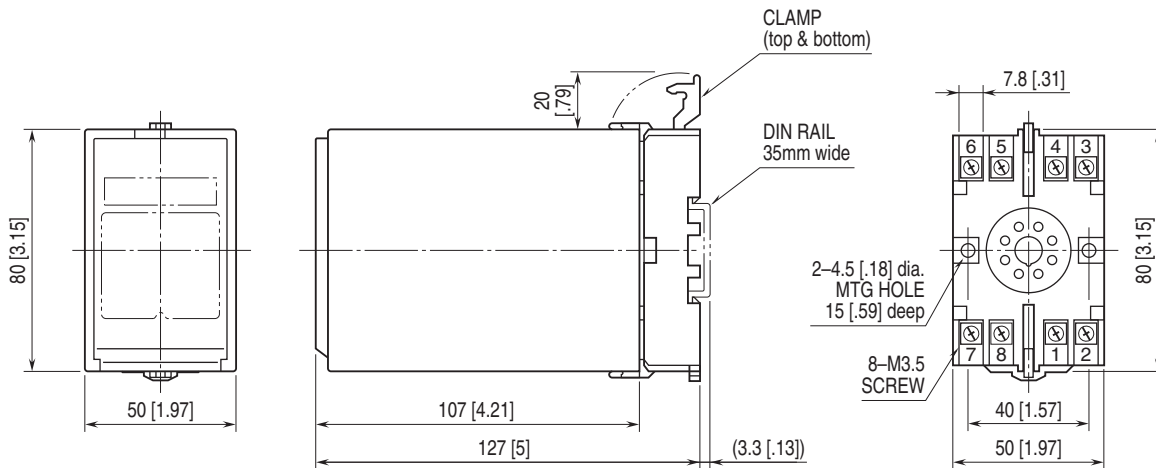

• When mounting, no extra space is needed between units.

SCHEMATIC CIRCUITRY & CONNECTION DIAGRAM

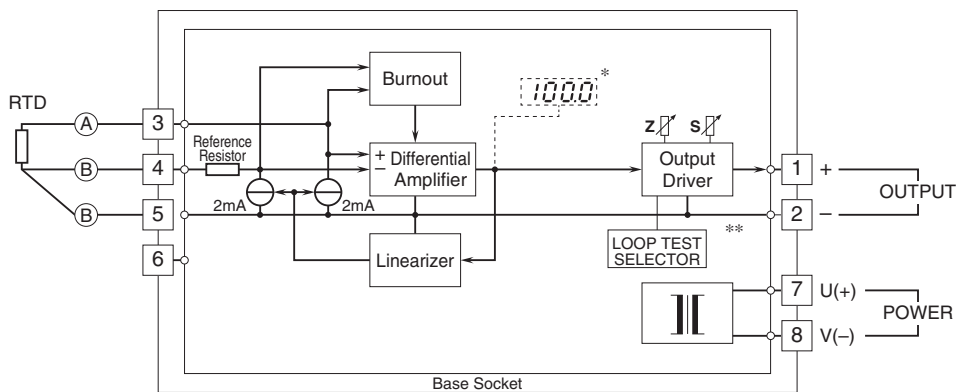

* Option /E, E2
 ** Option /E2



Specifications are subject to change without notice.